

RAJKOT MUNICIPAL CORPORATION



e-Tender : RMC/DRN/20-21/
Bid Documents for

Name of work	Providing, Lowering, Laying, Jointing and Testing Work of 600 mm dia NP3 class pipe and manhole work for Sewage house Connection system Under Rajkot Underground Sewerage work near Kalawad Road Drainage Pumping Station in Ward No.10
a) Estimated cost.	a) Rs.15,58,000/-
b) Amount of EMD	b) Rs.15,580/-
c) Tender Fee	c) Rs.1,125/-
d) Time limit for completion of work	d) 4 Months
e) Minimum amount of Performance bond price (Security Deposit)	e) 5 (Five) percent of contract price



AUGUST – 2020

:: Milestone dates of e-Tendering ::

1	Downloading of e-TENDER documents	07-08-2020 to 17-08-2020 1800 hrs.
2	Online submission of e-TENDER	17-08-2020 up to 1800 hrs.
3	Submission of EMD, Tender fee, Documents required for pre-qualification and other necessary documents in Person / Regd.A.D. / Speed Post / Courier.	19-08-2020 up to 1800 Hours
4	Opening of online tender(Technical bid)	19-08-2020 at 1800 Hours onwards
5	Verification of submitted documents (EMD, Tender fee, Documents required for pre-qualification and other necessary documents.)	20-08-2020 at 1100 Hours
6	Agency to remain present in person along with original documents for verification	20-08-2020 between 1200 to 1300 Hours
7	Opening of Online Price Bid	21-08-2020 at 1100 Hours onwards (If possible)
8	Tender Validity Period	180 (One hundred eighty)

CITY ENGINEER
Drainage Department,
Rajkot Municipal Corporation,
Shri Harisinhji Gohil Zonal Office,
West Zone, First Floor
150 Feet Ring Road, B/h.Big Bazaar,
Rajkot-360005

RAJKOT MUNICIPAL CORPORATION

Bid Documents For

Providing, Lowering, Laying, Jointing and Testing Work of 600 mm dia NP3 class pipe and manhole work for Sewage house Connection system Under Rajkot Underground Sewerage work near Kalawad Road Drainage Pumping Station in Ward No.10

PART-I

Section-1 Invitation to Bid, Introduction, Information to the Tenderer, e-Tender Declaration Form, Instructions to Tenderer and Formats.

Section-2 General Conditions of Contract

PART-II

Section-3 Technical Specifications

Section-4 Schedule of Drawings

PART-III

Bill of Quantities (With Price)

ABBREVIATIONS

Statement showing the details of abbreviations.

Full Form	Abbreviation
City Engineer	CE
Operation and Maintenance	O&M
Net Present Value	NPV
Engineering Procurement and Construction	EPC
Paschim Gujarat Vij Company Limited	PGVCL
Critical Path Method	CPM
Reinforced Cement Concrete	RCC
High Ground Level Reservoir	HGLR
Kilometer	KM
Mild Steel	MS
Bureau of Indian Standard	BIS
American Water Works Association	AWWA
American Petroleum Industries	API
Million Liter per Day	MLD
High Yield Strength Deformed bar	HYSD
Corrosion Resistance Steel	CRS
Ordinary Portland Cement	OPC
American Standard for Testing of Material	ASTM
Flux Compensated Magnetic Amplifier	FCMA
Cost Insurance and freight	CIF
Free On Board	FOB
EX – Works	EXW
PROJECT MANAGEMENT CONSULTANT	PMC

I N D E X

Sr No	Particulars
1	Invitation to Bid
2	Introduction
3	Information to the Tenderer
4	e-Tender Declaration form
5	Instructions to the Tenderer
6	Formats
7	General Conditions of Contract
8	Technical specifications
9	Additional Conditions
10	Schedule of Drawings
11	Bill of Quantities
12	Note on Schedule

RAJKOT MUNICIPAL CORPORATION
e-Tender Notice

Rajkot Municipal Corporation, Drainage Department, Shri Harisinhji Gohil Zonal Office, West Zone, First Floor 150 Feet Ring Road, B/h.Big Bazaar, Rajkot-36005, invites e-Tenders with two bid system by from the experienced contractors registered in GWSSB/ State Government/ Central Government in appropriate class for work of providing sewerage system for the following works as detailed below.

Sr. No.	Name of work	a) Estimated cost b) Amount of EMD c) Tender Fee d) Time limit for completion of work e) Registration Class
1	Providing, Lowering, Laying, Jointing and Testing Work of 600 mm dia NP3 class pipe and manhole work for Sewage house Connection system Under Rajkot Underground Sewerage work near Kalawad Road Drainage Pumping Station in Ward No.10	a) Rs.15,58,000 /- b) Rs.15,580/- c) Rs.1,125/- d) 4 Months e) Class 'E-1' & Above

:: Milestone dates of e-Tendering ::

1	Downloading of e-TENDER documents	07-08-2020 to 17-08-2020 1800 hrs.
2	Online submission of e-TENDER	17-08-2020 up to 1800 hrs.
3	Submission of EMD, Tender fee, Documents required for pre-qualification and other necessary documents in Person / Regd.A.D. / Speed Post / Courier.	19-08-2020 up to 1800 Hours
4	Opening of online tender(Technical bid)	19-08-2020 at 1800 Hours onwards
5	Verification of submitted documents (EMD, Tender fee, Documents required for pre-qualification and other necessary documents.)	20-08-2020 at 1100 Hours
6	Agency to remain present in person along with original documents for verification	20-08-2020 between 1200 to 1300 Hours
7	Opening of Online Price Bid	21-08-2020 at 1100 Hours onwards (If possible)
8	Tender Validity Period	180 (One hundred eighty)

- All bidders must submit tender fee and bid security as above either directly deposited in ICICI Bank Account No.015305010638 (Rajkot Municipal Corporation) IFSC Code ICIC0000153 or submit at the below mentioned address in form of Demand draft in favour of "Rajkot Municipal Corporation", Rajkot, from any Nationalized Bank or Schedule Bank (except Cooperative Bank) in India. The Receipt of Professional Tax Paid for current Year, address proof and ID proof shall have to be submitted along with physical submission of required documents at the below mentioned address.

Office of the City Engineer,
Drainage Department,
Rajkot Municipal Corporation,
Shri Harisinhji Gohil Zonal Office,
West Zone, First Floor
150 Feet Ring Road, B/h.Big Bazaar,
Rajkot-360005.

The pre-qualification requirement for work is as under:

i) Financial Criteria:

- An average annual turnover of last seven years should not be less than 50% of tender amount.
- Working capital (to be demonstrated by the bidder in form of confirmed credit line from reputed Bank or the bidder's own audited financial statement taking into account current commitment) and appropriate class Registration shall be Class 'E-1' and above from any statutory Govt. Body

institute like State PWD, State Irrigation Department, CPWD etc. Solvency shall be issued by Nationalized Bank or Multi State Scheduled Bank and that must not be less than Rs.2.00 Lacs for this work.

3. Available Bid Capacity-ABC must be more than the tender amount.
4. Enhancement factor can be applied as per Table-I to derive present value.

ii) Experience Criteria for work is as under:

1. The bidder should possess minimum experience of work which is / are completed in last seven years.

At least one work completed of similar nature of 60% of tender amount in last seven years.

OR

At least two work completed of similar nature of 50% each of tender amount in last seven years.

2. The work of pipe gutter and storm water drain will also be considered as similar nature of work.
3. Bidder should have enough machinery and experienced personnel to supervise the work.
4. Joint Venture will not be permitted.

Note:

1. Enhancement factors as per table-I for last seven years will be applicable to arrive average annual turnover and finalize the magnitude of work done in last seven years.

Sr. No.	Year	Enhance Factor
1	Year of inviting tender (eg. 2020-21)	1.00
2	-1 (2019-20)	1.10
3	-2 (2018-19)	1.21
4	-3 (2017-18)	1.33
5	-4 (2016-17)	1.46
6	-5 (2015-16)	1.61
7	-6 (2014-15)	1.77
8	-7 (2013-14)	1.95

2. Working Capital must not be less than 25% of estimated cost.
3. Available Bid Capacity-ABC shall be submitted in detail and that can be find out by the following method.

ABC is calculated as $ABC = 2 * A * N - B$

Where,

A=Maximum value of works executed in any one year during the last seven years (updated to present price level by applying enhancement factor) taking in to account the completed as well as works in progress.

N=Number of years prescribed for completion of the works for which tenders are invited.

B=Value (present price level by applying enhancement factor) of existing commitments and on-going works to be completed during that next N year (period of completion of the works for which the tenders are invited.)

- After opening of Technical Bid, the procedure for the pre-qualification shall be adopted and the Price Bid of only successful qualified bidder shall be opened for final evaluation of the contract. The decision of Municipal Commissioner regarding the pre-qualification shall be final and binding to all the bidders.
- The contractor shall have to quote their rates including GST and other taxes and the Invoice with break-up of GST is to be submitted accordingly, failing which, such amount will be deducted from the bill of the agency and deposited accordingly.

The contractor shall have to purchase the material required for this tender work, only from the supplier having registered GST Number. RMC will not be responsible to pay any amount towards GST if the material is purchased from the unregistered supplier / not having GST Number.

- The Tender of those bidder(s) those who fails to submit the required documents physically within the stipulated date and time, will be treated as non responsive and their Price Bid will

not be opened.

- Conditional Tenders will be out rightly rejected.
- Financial Data like seven Years Turn over, Experience, Tender Fee & EMD details, Registration details, shall be furnished by summarizing in a single table as per given format in Annexure-P. All details submitted shall be duly signed and stamped by the Agency.
- The bidder(s) submitting the tender shall also have to submit the copy of ESIC & EPF Registration document along with the other documents, duly self attested, failing which, the tender of such bidder(s) will be considered as non-responsive and their online price bid will not be opened.
- While furnishing Experience Data & Bank Documents, the agency submitting the tender shall have to provide the Contact Address, Phone No., Fax No, e-mail address of the authorities issuing the Experience Certificate for confirmation by this office. In case of failure of confirmation, the tender will be liable to be rejected out rightly.
- The bidder(s) submitting the tender shall also have to submit the copy of ESIC & EPF Registration document along with the other documents, duly self attested, failing which, the tender of such bidder(s) will be considered as non-responsive and their online price bid will not be opened.
- Commissioner, Rajkot Municipal Corporation, Rajkot, reserves the right to accept/reject any or all e-Tender(s) without assigning any reasons thereof.

City Engineer
Rajkot Municipal Corporation

Introduction

This work of Providing, Lowering, Laying, Jointing and Testing Work of 600 mm dia NP3 class pipe and manhole work for Sewage house Connection system Under Rajkot Underground Sewerage work near Kalawad Road Drainage Pumping Station in Ward No.10, which has sanctioned value of Rs.15,58,000/-. The work is to be carried out in hard rock in residential area and on main roads. Under the circumstances, the contractor shall have to carry out the excavation by controlled blasting or breaker only. In this region, the water table remains high for the period of three months after monsoon and as such a proper dewatering arrangement is required to be made. The pipes shall have to be procured from the reputed agency and same shall be BIS Mark.

The excavated stuff shall have to be removed immediately as otherwise same will obstruct to the traffic of the city. Since work is to be carried out in residential area, a proper care on safety measure will be required to avoid fatal accident. It would be more desirable that the agency should take insurance of labour as well as work.

-X-X-X-X-X-

: INFORMATION TO THE TENDERER :

1	Testing period	01 (one) Month
2	Period of liability for defects	Twelve Months after issuance of the completion certificate.
3	Compensation for delay	0.1 (zero point one) percent of the contract value per each day of delay subject to a maximum up to 10 (ten) percent of the contract value or as decided by the Municipal Commissioner

e-TENDER DECLARATION FORM

TO
The Commissioner
Rajkot Municipal Corporation
Rajkot.

Name of Work :

Providing, Lowering, Laying, Jointing and Testing Work of 600 mm dia NP3 class pipe and manhole work for Sewage house Connection system Under Rajkot Underground Sewerage work near Kalawad Road Drainage Pumping Station in Ward No.10

Ref : _____

Dear Sir,

I/We the undersigned have carefully gone through and clearly understood the tender documents comprising Notice Inviting Tenders, Articles of Agreement, Scope of work, Definition of terms, Instruction to Tenderer, Condition of Contract, Special condition of contract, Appendices, Specification, Schedule of quantities and tendered drawing furnish by The Rajkot Municipal Corporation. I/We have satisfied myself/ourselves as to the location of site, examined drawings.

I/We do hereby offer to execute and complete the whole of work within the time specified all in accordance with the specifications, designs, drawing and instructions in writing referred to in the said documents and with such materials as are provided for at the respective rates which I/We have quoted in the schedule-B or at such other rates as may be fixed under provisions of these conditions.

In the event of this tender being accepted I/We agree to enter into agreement as and when required and execute the contract, according to your Form of Agreement or in default where of I/We myself/our self to forfeit the 'Earnest Money' Deposit.

I/We understand that if I/We shall not enter in agreement within 20 days from the date of receipt of letter of acceptance, you will forfeit the earnest money paid by me/us and take necessary action as deemed fit.

Contractor

I/We have enclosed a DEMAND DRAFT as an "Earnest Money Deposit " for the sum as prescribed in the tender document, the full value of which is to be absolutely forfeited to the Owner should I/We fail to commence the works specified. Otherwise the said sum shall be retained by the Owner as on account of such 'Security Deposit' as provided for in the aforesaid documents.

I/We agree not to employ Sub-Contractors other than those that may be approved in accordance with conditions in the aforesaid documents.

I/We understand that you are not bound to accept the lowest or any tender which you may receive.

I/We shall refer all disputes arising out of or relating to the agreement to the arbitration in accordance with conditions of contract.

I/We am/are bound to execute the job if the work order is issued within 180 days from the date opening of the tender.

I/We agree to pay the Government Income-Tax, CGST, SGST, Sales Tax on contract, Professional Tax and Other Taxes prevailing from time to time on such items on which the same leviable and the rates quoted by me/us are inclusive of the same.

Date: - _____

Yours faithfully,

Signature of Contractor

Address:

Contractor.....

INSTRUCTIONS TO TENDERER

IT 1. GENERAL

The contract documents may be secured in accordance with the Notice Inviting e-TENDER for the work called. The work shall include supply of materials necessary for construction of the work.

IT 2. INVITATION TO e-TENDER

The Rajkot Municipal Corporation hereinafter referred as the Corporation will receive e-Tenders for the work of as per the specifications and schedule of prices in the e-Tender document. The e-Tenders shall be opened online as specified in the e-Tender notice in the presence of interested Tenderers or their representatives. The Corporation reserves the right to reject the lowest or any other or all e-Tenders or part of it which in the opinion of the Corporation does not appear to be in its best interest, and the Tenderer shall have no cause of action or claim against the Corporation or its officers, employees, successors or assignees for rejection of his e-Tender.

IT 3. LANGUAGE OF e-TENDER

e-TENDERS shall be submitted in English, and all information in the e-Tender shall also be in English. Information in any other language shall be accompanied by its translation in English or Gujarati. The Correspondence language regarding e-tendering shall be in English or Gujarati. Failure to comply with this may make the e-Tender liable to rejection.

IT 4. QUALIFICATIONS OF TENDERERS

- A. The Tenderers shall abide by the laws of the Union of India and of Gujarat State and legal jurisdiction of the place where the works are located.
- B. The Tenderer shall furnish a written statement of financial and technical parameters with details and documents along with his e-Tender which contains namely as below:

- i. The Tenderer's experience in the fields relevant to this contract.
- ii. The Tenderer's financial capacity/resources and standing over at least 7 (Years) years.
- iii. The Tenderer's present commitments (Jobs on hand).
- iv. The Tenderer's capability and qualifications of himself and his regular staff etc.
- v. Plants and Machinery available with the Tenderer for the work Tendered.

~~C. Joint venture :-~~

- ~~▪ Joint venture will be permitted with maximum up to 3 (three) members as a partner, however all the fees, guarantee amount etc will be in the name of lead partner.~~
- ~~▪ In Joint Venture, the lead partner as well as any other partner should have experience of similar nature of work, minimum 51% of the estimated cost.~~
- ~~▪ Experience and Financial criteria will be applicable as per share in JV.~~
- ~~▪ All Partners of JV are responsible for the execution of the work.~~
- ~~▪ Other Partner must have not less than 20% financial share in the JV.~~

~~Bids submitted by a joint venture of two or three firms as partners shall comply with the following requirements.~~

- ~~i. Tender fee, Earnest Money Deposit, Security Deposit and other financial details will be in the name of the lead partner.~~

- ~~ii. All the partners shall have to enter into the Joint venture agreement and original agreement duly notarized shall have to be submitted along with tender documents.~~
- ~~iii. The bid, and in case of a successful bid, the Form of Contract Agreement, shall be signed so as to be legally binding on all partners.~~
- ~~iv. One of the partners shall be authorized to be in charge, and his authorization shall be evidenced by submitting a power of attorney by legally authorized signatories of all the partners.~~
- ~~v. The partner in charge shall be authorizes to incur liabilities, receive payments and receive instructions for and on behalf of any or all partners of the joint venture and the entire execution of the Contract.~~
- ~~vi. All partners of the joint venture shall be jointly and severally liable for the execution of the Contract in accordance with the Contract terms, and relevant statement to this effect shall be included in the authorization mentioned under (iv) above as well as in the Bid Form and the Form of Contract Agreement (in case of successful bid); and~~
- ~~vii. Permissible Joint venture partners shall be restricted to three numbers.~~

IT 5. e-Tender DOCUMENTS

The e-Tender documents and drawings shall comprehensively be referred to as e-Tender document. The several sections form in the document are the essential parts of the contract and a requirement occurring in one shall be as binding as though occurring in all, they are to be taken as mutually, explanatory and describe and provide for complete works.

IT 6. EXAMINATION BY TENDERERS

- A. At this own expense and prior to submitting his e-Tender, each Tenderer shall (a) examine the Contract Documents, (b) visit the site and determine local conditions which may affect the work including the prevailing wages and other pertinent cost factors, (c) familiarize, himself with all central, state and local laws, ordinance, rules regulations and codes affecting the material supply including the cost of permits and licenses required for the work and (d) correlate his observations, investigations, and determinations with the requirements of the e-Tender Documents, site & subsoil investigation.
- B. The e-Tender is invited on..% . rate and contractor shall have to quote his price on % bases above or below in the schedule -B./ Price Schedule. The works shall have to be completed in all respect as stated in the e-Tender document to the satisfaction of the Corporation.
- C. The following comprises in Contract Documents at a price as prescribed in tender notice.

e-Tender Document:

Part-I

- 1. Notice inviting Tenderers.
- 2. Information to the Tenderer.
- 3. e-TENDER declaration form
- 4. Instructions to the Tenderer.
- 5. Formats
- 6. General conditions of contract

Part-II

Technical specifications & Bid Drawings

Part-III

- a. Bid Form (With Price)
- b. Preamble to Price schedule
- c. Price Schedule (Schedule-B)

- D. Copy of the e-Tender Document should be completed, checked in a responsible manner, digitally signed, and submitted. Tender security Bond shall be submitted in person by the stipulate date, which shall form the part of e-Tender.

The e-Tender is required to complete with all the pages in which entries are required to be made by the Tenderer are contained in the e-Tender documents and the Tenderer shall not take out or add to or amend the text of any of the documents except in so far as may be necessary to comply with any addenda issued pursuant to Clause IT. 16 hereof.

IT 7. EARNEST MONEY DEPOSIT:

- A. Each Tenderer must submit a receipt of deposit as Tender guarantee towards Earnest Money amount as prescribed in tender notice in the form of crossed Demand Draft in favor of "Rajkot Municipal Corporation", from any Nationalized Bank or Schedule Bank (except Cooperative Bank) in India acceptable to owner payable at Rajkot. The Tender Bond, shall be valid for a period of not less than hundred and eighty (180) days from the date the e-Tenders are opened and shall comply with the requirements for Bond as stipulated in the General conditions of contract. The Tender guarantee bond will be held by the owner as a guarantee that the Tenderer, if awarded the contract, will enter into the contract agreement in good faith and furnish the required bonds. Any e-Tender not accompanied by a Tender guarantee in the form of earnest money deposited for the sum stipulated in the e-Tender Document will be summarily rejected.
- B. The Earnest Money Deposit will be refunded to the unsuccessful Tenderers after an award has been finalized.
- C. The Earnest Money Deposit (Tender Guarantee) will be forfeited in the event, the successful Tenderer fails to accept the contract and fails to submit the "Performance Guarantee Bonds to the Owner as stipulated in this e-Tender documents within twenty (10) days after receipt of notice of award of contract.
- D. The Earnest Money Deposit of the successful Tenderer shall be returned after the performance guarantee bond, as required, is furnished by the contractor.
- E. Within 10 (ten) days from the date of issue of the letter accepting his tender, the successful Bidder shall furnish the required Security Deposit for performance and plus additional security if any for unbalanced bids in accordance with the condition of the contract and attend the office of the Engineer In-charge for execution of the contract documents. If he fails to furnish the Security Deposit for performance or to execute the contract for the work offered to him, his EMD shall be forfeited and the Bidder may be Black Listed / Debarred from tendering for further works of RMC for three years.
- F. No interest shall be paid by the owner on any e-Tender guarantee.

IT8. PREPARATION OF e-TENDER DOCUMENTS

Tenderers are required to note the following while preparing the e-Tender Documents:

- A. e-Tender shall be submitted on the e-TENDER form bound here in English. All statements shall be properly filled in. Numbers shall be stated both in words and in figures where so indicated.
- B. All entries or prices and arithmetic shall be checked before submission of the e-TENDERS. If there is discrepancy between the rates quoted in figures and in words, the rates expressed in words shall be considered as binding.
- C. Each e-Tender shall be accompanied by the prescribed e-Tender security bond and other required documents and drawings. All witnesses and sureties shall be persons of status and probity and their full names, occupations and addresses shall be stated below their signature.
- D. Variation to the contract Documents requested by the Tenderer may be affixed and duly signed and stamped. Such variations may be approved or refused by the Corporation is not obliged to give reason for his decisions.

IT 9. SUBMISSION OF e-TENDER DOCUMENTS

Tenderers are requested to submit the e-TENDER Documents on following lines.

- A. Volume containing following documents:
 - I. e-TENDER security bond (Earnest Money)
 - II. Certificates as registered contractor with Government of Gujarat or appropriate authority.
 - III. Tenderer's financial capability and standing over at least past three years
 - IV. Current Income Tax clearance certificate. (DELETED)
 - V. Tenderer's experience in the field relevant to this contract.
 - VI. A list of the equipment the Tenderer possesses and that which he proposed to acquire and use for the purpose related to the work.
 - VII. Tenderer should submit All the drawings which they have received along with e-Tenders.
 - ~~VIII. A original copy of Joint venture agreement duly notarized.~~

The time limit for receipt of e-Tender shall strictly apply in all cases. The Tenderers should therefore ensure that their e-Tender is received by the competent authority The Rajkot Municipal Corporation at the required place before expiry of the time limit. No delay on account of any cause for receipt of e-Tender shall be entertained.

The e-Tender must contain the name address and residence and place of business of the person or persons submitting the e-Tender and must be digitally signed.

e-TENDERS by partnership firm must be furnished with the full names and addresses of all partners and be signed by one of the members of the partnership or by a legally authorized representative holding power of attorney followed by signature and designation of the person of person signing.

e-TENDERS by corporations/companies must be signed with the legal name of the Corporation/Companies by the president/or by the secretary or other person or persons legally authorized to bind the Corporation/Company in the matter.

IT 10 TENDER VALIDITY PERIOD

The validity period of the e-Tender submitted for this work shall be of One eighty (180) calendar days from the date of opening of the Online Price Bid and that the Tenderer shall not be allowed to withdraw or

modify the e- Tender offer on his own during the validity period. The Tenderer will not be allowed to withdraw the e-Tender or make any modifications or additions in the terms and conditions on his own e-Tender. If this is done then the owner shall, without prejudice to any other right or remedy, be at liberty to reject the e-Tender and forfeit the earnest money deposit in full.

IT 11 GENERAL PERFORMANCE DATA

Tenderers shall present all the information which sought for in the e-Tender document in form of various schedules if given. e-TENDERS may not be considered if left blank or the schedules are not properly filled in.

IT 12 SIGNING OF e-TENDER DOCUMENTS

If the e-Tender is made by an individual it shall be signed with his full name above his current address. If the e-Tender is made by a proprietary firm, it shall be signed by the proprietor above his name and the name of his firm with his current address.

If the e-Tender is made by a firm in partnership, it shall be signed by all the partners of the firm above their full names and current address, or by a partner holding the power of attorney for the firm, in which case a certified copy of the power of attorney shall accompany the e-TENDER. A certified copy of the partnership deed, current addresses of all the partners of the firm shall also accompany the e-Tender.

If the e-Tender is made by a limited company or a limited corporation, it shall be signed by a duly authorized person holding the power of attorney, shall accompany the e-Tender. Such limited company or corporation may be required to furnish satisfactory evidence of its existence before the contract is awarded.

If the e-TENDER is made by a group of firms, the sponsoring firm shall submit complete information pertaining to each firms in the group and state along with the bid as to which of the firms shall have the responsibility for e-Tendering and for completion of the contract documents and furnish evidence admissible in law in respect of the authority to such firms on behalf of the group of firms for e-Tendering and for completion of contract documents. The full information and satisfactory evidence pertaining to the participation of each member of the group of firms in the e-Tender shall be furnished along with the e-Tender.

All witnesses and sureties shall be persons of status and probity and their full names, occupations and addresses shall be stated below their signatures. All the signatures in the e-Tender document shall be dated.

IT 13 WITHDRAWAL OF TENDERS

If, during the tender validity period, the Tenderer withdraws his Tender, Tender security (Earnest Money) shall be forfeited and Tenderer will be debarred for next three years to quote in R.M.C.

IT 14 INTERPRETATIONS OF e-TENDER DOCUMENTS

Tenderers shall carefully examine the e-TENDER Document and fully inform themselves as to all the conditions and matters which may in any way affect the work or the cost thereof. If a Tenderer finds discrepancies, or omission from the specifications or other documents or should be in doubt as to their meaning, he should at once address query to the City Engineer, R.M.C. The result of interpretation of the e-TENDER will be

issued to all Tenderers as addendum.

IT 15 ERRORS AND DISCREPANCIES IN e-TENDERS

In case of conflict between the figures and words in the rates the rate expressed in words shall prevail and apply in such cases.

IT 16 MODIFICATION OF DOCUMENTS

Modification of specifications and extension of the closing date of the e-Tender, if required will be made by an addendum. Each addendum will be made available online to all Tenderers. These shall form a part of e-Tender. The Tenderer shall not add to or amend the text of any of the documents except in so far as may be necessary to comply with any addendum.

ADDENDA

Addenda form part of the Contract Documents, and full consideration shall be given to all Addenda in the preparation of e-Tender. Tenderers shall verify the number of Addenda issued, if any and acknowledge the receipt of all Addenda in the e-TENDER Failure to so acknowledge may cause the e-Tender to be rejected.

- A. The Owner may issue Addenda to advise Tenderers of changed requirements. Such addenda may modify previously issued Addenda.
- B. No addendum may be issued after the time stated in the notice inviting e-Tenders.

IT 17. TAX AND DUTIES ON MATERIALS

All charge on account of excise duties, Central / State, sales tax, work contract tax and other duties etc. on materials obtained for the works from any source shall be borne by the contractors. (P) or 'C' or 'D' form shall not be supplied by the owner.

IT 18 EVALUATION OF e-TENDERS

While comparing e-Tenders, the Rajkot Municipal Corporation shall consider factors like price offer is workable with the market price, efficiency and reliability of construction method proposed, compliance with the specifications, relative quality, work done in past with Rajkot Municipal Corporation or other Government Organizations, litigation issues etc. Evaluation criteria specifically mentioned in the specification will also be taken into consideration in the evaluation of e-Tenders.

IT 19 TIME REQUIRED FOR COMPLETION

The completion period mentioned in this schedule is to be reckoned from the date of notice to proceed. Total completion period as mentioned in tender notice, will reckon from the date of issue of notice to proceed and contractor should adhere to this completion time. Monsoon period from 1st July to 30th September will be considered as non-working period and hence excluded in time limit.

IT 20 POLICY FOR TENDER UNDER CONSIDERATION

TENDER shall be termed to be under consideration from the opening of the e-Tender until such time any official announcement or award is made.

While e-Tenders are under consideration, Tenderers and their representative or other interested parties are advised to refrain from contacting by any means any corporations personnel or representatives on matters related to the e-Tenders under study. The Corporation's

representatives if necessary will obtain clarification on e-Tenders by requesting such information from any or all the Tenderers, either in writing or through personal contact, as may be necessary. The Tenderer will not be permitted to change the substance of his e-Tender after e-Tenders have been opened. This includes any post Tender price revision. Non-compliance with his provision shall make the Tender liable for rejection.

IT 21 PRICES AND PAYMENTS

The Tenderer must understand clearly that the prices quoted are for the total works or the part of the total works quoted for and include all costs due to materials, labour, equipment, supervision, other services, royalties, taxes etc. and to include all extra to cover the cost. No claim for additional payment beyond the prices quoted will be entertained and the Tenderer will not be entitled subsequently to make any claim on any ground.

IT 22 PAYMENT TERMS

The terms of payment are defined in the General Conditions of Contract and Technical specifications. The Corporation shall not under any circumstances relax these terms of payment and will not consider any alternative payment terms. Tenderers should therefore in their own interest note this provision to avoid rejection of their e-Tenders.

IT 23 AWARD

Award of the contract or the rejection or e-TENDERS will be made during the Tender validity period. A separate Schedule-B (Price Schedule) is given. The contractors are requested to quote their price offer in % below or above on the given price in the schedule-B only.

- A. After all contract contingencies are satisfied and the Notice of Award is issued, the successful Tenderer shall execute the Contract Agreement within the time stated and shall furnish the Bond as required herein. The contract Agreement shall be executed, in form stipulated by the Owner.
- B. If the Tenderer receiving the Notice of Award fails or refuses to execute the Contract Agreement within the stated time limit or fails or refuses to furnish the Bond as required herein. The Owner may annul his award and declare the e-Tender security forfeited and will take action as deemed fit.
- C. A corporation, partnership firm or other consortium acting as the Tenderer and receiving the award shall furnish evidence of its existence and evidence that the officer signing the contract agreement and Bonds for the corporation, partnership firm or other consortium acting as the Tenderer is duly authorized to do so.

IT 24 SIGNING OF CONTRACT

The successful Tenderer shall be required to execute the contract agreement within 20 days of receipt of intimation to execute the contract, failing which the Corporation will be entitled annul to the award and forfeit the Earnest Money Deposit. The person to sign the contract document shall be person as detailed in Article IT. 12 (signing of e-Tender documents).

IT 25 DISQUALIFICATION

A e-Tender shall be disqualified and will not be taken for consideration if,

- (a) The Tender Security Deposit is not deposited in full and in the manner as specified as per Article IT. 7 i.e. Earnest Money Deposit.
- (b) The e-Tender is in a language other than English or Gujarati does not contain its English or Gujarati Translation in case of other language adopted for e-Tender preparation.
- (c) The e-Tender documents are not signed by an authorized person (as per Article IT. 12 i.e. signing of e-Tender documents).
- (d) The general performance data for qualification is not submitted fully (as per Article IT 11 i.e. General performance Data).
- (e) Tenderer does not agree to payment terms defined as per Article IT. 22 i.e. payment terms.

A. A e-Tender may further be disqualified if,

- (a) Price variation is proposed by the Tenderer on any principle other than those provided in the e-TENDER Documents.
- (b) Completion schedule offered is not consistent with the completion schedule defined and specified in e-Tender document.
- (c) The validity of e-Tender is less than that mentioned in Article IT. 11 i.e. e-Tender validity period.
- (d) Any of the page or pages of e-Tender is/are removed or replaced.
- (e) Any condition which effect the cost.

IT 26 PERFORMANCE GUARANTEE (SECURITY DEPOSIT)

As a contract security the Tenderer to whom the award is made shall furnish a performance guarantee (Security deposit) for the amount of 5% of the contract price to guarantee the faithful performance, completion and maintenance of the works of the contract in accordance with all conditions and terms specified herein and to the satisfaction of the Engineer-in-charge and ensuring the discharge of all obligations arising from the execution of contract in the forms mentioned below:

- a. By a Demand Draft on the Rajkot Branch of any Nationalized Bank or Schedule Bank (except Cooperative Bank) in India.
- b. A Fixed Deposit Receipt of a Nationalized Bank or Schedule Bank (except Cooperative Bank) duly endorsed in favour of the "RAJKOT MUNICIPAL CORPORATION", Rajkot.

The above DD or FDR shall be delivered to the Corporation within ten (10) days of the notice of award and at least three (3) days before the contract agreement is signed unless otherwise specified by the Engineer- in-charge. Alternatively, the contractor may at his option deposit an amount of 2.5% of the value of the contract price within ten days and the balance 2.5% to be recovered in installments through deduction @ the rate of 10% from the running account bills.

Bank Guarantee will not be accepted for this purpose.

On due performance and completion of the contract in all respects, the performance guarantee will be returned to the contractor without any interest after the defect liability period is over.

IT 27 STAMP DUTY

The successful Tenderer shall have to enter into an agreement on a non-Judicial Stamp Paper / Franking Machine, as per Stamp Duty Act 1958

as per the form of the agreement approved by the Corporation. The cost of stamp paper and adhesive stamp shall be born by the contractor.

IT 28 BRAND NAMES

Specific reference in the specifications to any material by manufacturer's name, or catalogue shall be constructed as establishing a standard or quality and performance and not as limiting competition and the Tenderer in such cases, may at his option freely use only other product, provided that it ensures an equal of higher quality than the standard mentioned and meets Corporation approval.

IT 29 NON TRANSFERABLE

e-TENDER documents are not transferable.

IT 30 COST OF e-TENDERING

The owner will not defray expense incurred by Tenderers in e- Tendering.

IT 31 EFFECT OF e-TENDER

The e-Tender for the work shall remain for a period of 180 calendar days from the date of opening of the e-Tenders for this work and that the Tenderer shall not be allowed to withdraw or modify the offer in his own during the period. If any Tenderer withdraws or makes any modification or additions in the terms and conditions of his own e-Tender, then the Corporation shall, without prejudice to any other right or remedy, be at liberty to reject the e-Tender and forfeit the earnest money in full.

IT 32 CHANGE IN QUANTITY

The Corporation reserves the right to waive any information in any e-Tender and to reject one or all e-Tenders without assigning any reasons for such rejection and also to vary the quantities of items or group as specified in the scheduled of prices as may be necessary.

IT 33 NEW EQUIPMENT AND MATERIAL

All materials, equipment and spare parts thereof shall be new, unused and originally coming from manufacturer's plant to the Corporation. The rebuilt or overhauled equipment/materials will not be allowed to be used on works.

IT 34 RIGHTS RESERVED

The owner reserves the right to reject any or all e-Tenders, to waive any informality or irregularity in any e-Tender without assigning any reason. The owner further reserves the right to withhold issuance of the notice to proceed, even after execution of the contract agreement. No payment will be made to the successful Tenderer on account of such withholding. The owner is not obliged to give reasons for any such action.

IT 35 ADDITIONAL RIGHTS RESERVED

The Commissioner, Rajkot Municipal Corporation, reserves right to reduce the scope of work & split the e-Tender in two or more parts without assigning any reason even after the awards of contract.

IT 36 MOBILIZATION ADVANCE

No mobilization advance or advance on Material or machinery will be given.

IT 37 CONDITIONAL e-TENDERS

The scope of work is clearly mentioned in the e-Tender documents. The contractor shall have to carry out the work in accordance with the details specifications. No condition will be accepted. The conditional e-Tender will liable to be rejected.

IT 38 1% CESS & REGISTRATION:

For the welfare of labour working under construction Industry, the agency shall have to take the registration with competent authority as per Circular No.CWA/2004/841/M-3 dated 30-01-2006 of Government of Gujarat. Rajkot Municipal Corporation will deduct 1% Cess of the value of work and will deposit the same in Government.

IT 39 PROFESSIONAL TAX

The bidder shall have to pay the Professional Tax for current financial year imposed by Government of Gujarat, and also produced Enrollment Certificate for the same.

Asst.Engineer
R.M.C.

Dy.Ex. Engineer
R.M.C.

City Engineer
R.M.C.

Signature of Contractor.

FORMATS

APPENDIX – A

EACH MEMBER OF THE CONSORTIUM SHOULD GIVE ALL THE DETAILS FOR EACH OF THE FOLLOWING APPENDICES.

Sr. No.	Name of the Consortium Member	Role of the Member	Equity Stake in Project.

Signature of Contractor

APPENDIX - B

Financial Resources in ongoing projects

Sr. No	Description of ongoing projects	Total cost of work/contract	Members contribution (%)	Funds required to be contributed.
1	2	3	4	5

Signature of Contractor

APPENDIX - C
FINANCIAL INFORMATION

Year	Annual Turnover in Rs. Million			
	Underground Drainage Project	Civil Engineering Projects	Other Projects	Total
1	2	3	4	5

Signature of contractor

APPENDIX-D

PROVIDING, LOWERING, LAYING AND JOINTING OF RCC NP3 CLASS PIPES OF VARIOUS SIZE IN SEWERAGE SYSTEM AS A MAIN LINE IN ANY OF URBAN AREA COMPLETED AND COMMISSIONED AS A MAIN CONTRACTOR IN LAST SEVEN YEARS.

Sr. No	Name of the work	Name and address of client with contact number	Size and type of RCC pipe	Length in km	Date of award	Time of completion	Whether Project Under Litigation (Yes / No.) & reasons thereof

Signature of Contractor

APPENDIX – E
 PROVIDING, LOWERING, LAYING AND JOINTING OF STONEWARE PIPES RANGING 150 TO 250 MM
 DIA. SIZE IN SEWERAGE SYSTEM AS A MAIN LINE IN ANY OF URBAN AREA COMPLETED AND
 COMMISSIONED AS A MAIN CONTRACTOR IN LAST SEVEN YEARS.

Sr.No	Name of the work	Name & address of client with contact number	Size and type of Stoneware pipe	Length in km	Date of award	Time of completion	Whether Project Under Litigation (Yes / No.) & reasons thereof

Signature of Contractor

APPENDIX – F

WORK OF HOUSE CONNECTION WITH 100 MM DIA STONEWARE PIPES AND HOUSE CONNECTION
CHAMBER IN SEWERAGE SYSTEM OF ANY URBAN TOWN

Sr.No	Name of the work	Name & address of client with contact number	Size of house connection chamber and type of pipe with size	No.	Date award of	Time of completion	Whether Project Under Litigation (Yes /No.) and reasons thereof

Signature of Contractor

APPENDIX – G

EXPERIENCE IN MECHANIZED ROCK EXCAVATION WORKS

Sr. No	Name of agency	Excavation in cubic meter. In last 7 years	Project work	Department	Contract period day, month and year	Whether project under litigation (Y/N) and reason thereof

Signature of Contractor

APPENDIX – H
EXCAVATION IN HARD ROCK BY BLASTING IN URBAN TOWN

Sr.No	Name of the work	Name & address of client with contact number	Excavation in hard rock by controlled blasting or by breaker.	M ³	Date award of	Time of completion	Whether Project Under Litigation (Yes / No.) & reasons thereof

Signature of Contractor

APPENDIX – I

EXPERIENCE IN TURNKEY OR / AND EPC EXECUTION OF WATER RETAINING STRUCTURE VIZ; GSR, FILTER, SWIMMING POOL AS A MAIN CONTRACTOR – MINIMUM REQUIREMENT ONE PROJECT (With Similar Nature in Last 7 Years) Cost of the project should not be less than INR 5.0 millions.

Sr.No	Name of the Consortium Member	Capacity in ML	Cost of the project in Rs. Lakhs	Brief Details of Project components	Year of work done	Delay in months from the Scheduled date of completion

Note: - Capacity of water retaining structure should not be less than 3.0 ML

Signature of Contractor

APPENDIX – J

EXPERIENCE IN OTHER CIVIL WORKS PROJECTS AS A MAIN CONTRACTOR – MINIMUM REQUIREMENT
1 NO. OF PROJECTS

(Each work should be stated separately for each member of the consortium)

Cost of the project should not be less than INR 50.0 millions.

Sr No	Name of work with details of client and contact number	Cost of work in Million	Date of award and Time of completion	Whether Project Under Litigation (Yes/No) & reasons thereof

Signature of Contractor

APPENDIX – K

WORKS FOR WHICH BIDS ALREADY SUBMITTED

Sr. No.	Description of work	Place and State	Estimated Value of works Rs. In Lakhs	Stipulated period of completion	Date when decision is expected	Remarks if any

Signature of Contractor

APPENDIX – L
 INFORMATION ON BID CAPACITY (WORK FOR WHICH BIDS HAVE BEEN SUBMITTED AND WORKS WHICH ARE
 YET TO BE COMPLETED) AS ON THE DATE OF THIS BID (A) EXISTING COMMITMENTS AND ON-GOING WORKS

Sr. no.	Description of Work	Place and state	Contract No. & Date	Name and Address of the Employer	Value of Contract Rupees in Lakhs	Stipulated period of completion	Value of works remaining to be completed	Anticipated date of completion.

Signature of Contractor

APPENDIX – M

EXPERIENCE AS MAIN CONTRACTOR (Information on Management of Risks.)

Sr. No.	Project Details including title and location	Contract Cost (Rs.in Million)	Contract period (Start date - End date)	Actual cost at the end of contract (Rs. In Lakhs)	Actual Contract period (start date - End date)	Name, Address, Phone and Fax No. of the Owner's representative who could be contacted.

NOTE :

The Bidder shall furnish separate Table for individual packages.
The information should be provided for 2 Nos. of last projects.

Signature of Contractor

APPENDIX – N

DETAILS OF PLANTS & EQUIPMENTS OWNED BY THE CONTRACTOR

Sr. No.	Name of Plants/ Equipments	Make of Plants/ Equipments	Model & Year of purchase	Details of R.T.O. Registration	Cost of Plants/ Equipments	Location where the Plants/ Equipments Located	Hours utilized	Condition at present	Will be deployed on work or not?

Signature of Contractor

APPENDIX - O
ENGINEERING PERSONNEL

Sr. No	Name of person	Qualification	Experience	Since long the firm designation with and	Whether he will be spared for RMC work for months time.

Signature of Contractor

APPENDIX – P
General Information Details

Estimated Amount		Tender Fee	EMD							
Rs.15,58,000/-		Rs.1,125/-	Rs.15,580/-							
Name of Agency		Registration No./Class (Mini. "E-1" Class) & Above	Tender Fee Detail	EMD Details	Turnover Details (Last Seven Years Average 2013-14 to 2019-20)		Solvency Not Less than 2.00 Lac.	Available Bid Capacity (working Capital) As per Formula ABC = 2*A*N-B (Minimum)	Details of Certificate attached for Experience of Min. of single work.	
		Issuing Authority			Year	enhancement factor to be multiplied	Turn Over in Rs. with enhancement factor	Working Capital not Less Than 25% of Tender Amount	Maximum Value of work Executed in any one Year During the last Seven (up date to present price level by applying enhancement factor --- 10% above) years taking in to account	Name of Work Amount
Address	Class	Name of Bank & Bank Code, City	Name of Bank & Bank Code, City	2013-14	1.95		Name of Bank & Bank Code, City	Value (present price level by applying enhancement factor) of existing commitments and on-going works to be completed during that next N year (period of completion of		
				2014-15	1.77					
				2015-16	1.61					
Phone	Permission No.	Draft No.	Draft No.	2016-17	1.46		Solvency No.	Number of years prescribed for completion of the works for which tenders are invited		
Fax	Date :-	Draft Date	Draft Date	2017-18	1.33		Date	A= Max Value x Enhancement factor		
E-mail Address	Letter No			2018-19	1.21			N = Next N Year		
				2019-20	1.10			B = Present Value		
				Average				Bid Capacity = (2*A*N)-B		
								Attach the Calculation sheet and Mention Figure Here		

To derive B- Present Value Value (present price level by applying enhancement factor) of existing commitments on-going (i.e. Running) works Statement has been attached herewith.

Above all Details are True

Contractor Sign & Seal

Above Financial Details are True

Application Form(1) General Information

All individual firms and each partner of a consortium applying for qualification are requested to complete the information in this form. Nationality information to be provided for all owners or applicants who are partnerships or individually-owned firms.

Where the Applicant proposes to use named subcontractors for critical components of the works, or for work contents in excess of 10 percent of the value of the whole works the following information should also be supplied for the specialist subcontractor(s).

1.	Name of Firm	
2.	Head office address	
3.	Local office address	
4.	Telephone	Contact
5.	Fax	Telex
6.	Place of incorporation/registration	Year of incorporation/ registration
7.	e-mail ID	

Signature of Contractor

	Nationality of owners	
	Name	Nationality
1.		
2.		
3.		
4.		
5.		

Signature of Contractor

Name of Bidders officers / Persons to be contacted			
Name.	Address	Phone Nos.	Fax.

Signature of Contractor

<p>The applicant is an individual a proprietary firm a firm in partnership a Limited Company or Corporation a group of firms/consortium (if Yes, give completion information in respect of each partner)</p>	
<p>Attach the Organization Chart showing the structure of the organization including the names of the Directors and position of officers</p>	
<p>Number of years of experience : as a Prime Contractor (contractor shouldering major responsibility in own country other countries (specify country)</p>	
<p>in a consortium in own country other countries (Specify country)</p>	
<p>as a sub-contractor (specify main contractor) in own country other countries (Specify country)</p>	
<p>Name and address of any associates the applicant has in India (in case the applicant happens to be from foreign country) who are knowledgeable in the procedures of customs, immigration, taxes and other information necessary to do the work.</p>	
<p>For how many years has your organization been in business of similar work under its present name? What were your fields when your organization was established? Whether any new fields were added in your organization? And if so, when?</p>	

Signature of Contractor

Application Form (1A)

Structure and Organization

Were you ever required to suspend construction for a period of more than six months continuously after you started? If so, give the name of project and give reasons therefore.	
Have you ever left the work awarded to you incomplete? If so, give name of project and reasons for not completing work.	
In which fields of civil engineering construction do you claim specialization and interest?	
Give details of your experience in mechanized cement concrete lining and in modern concrete technology for manufacture and quality control.	
Give details of your experience in using heavy earth moving equipment and quality control in compaction of soils.	
Give details of your experience in Underground Drainage work in rocky area.	
Give details of civil work for drainage pumping station	
Give details for construction of sewerage treatment plant	
Give details for pumping machinery in drainage pumping station	

Signature of Contractor

SECTION - 2
GENERAL CONDITIONS OF CONTRACT

TABLE OF CONTESTS

No.	Description
GC-1	Definitions and Interpretations
GC-2	Location of site and accessibility
GC-3	Scope of work
GC-4	Ruling language
GC-5	Interpretation of Contract Document
GC-6	Contractor to understand himself fully
GC-7	Errors in submissions
GC-8	Sufficiency of e-TENDER
GC-9	Discrepancies
GC-10	Performance Guarantee (Security Deposit)
GC-11	Inspection of work
GC-12	Defect Liability
GC-13	Power of Engineer-In-Charge to give further instructions.
GC-14	Programme
GC-15	Sub-letting of work
GC-16	Sub-Contracts for temporary works, etc.
GC-17	Time for completion
GC-18	Extension of time
GC-19	Contract Agreement
GC-20	Liquidated damages
GC-21	Forfeiture of Security Deposit
GC-22	Action of Forfeiture of Security Deposit
GC-23	No compensation for alteration in or restriction in work
GC-24	In the event of death of contractor
GC-25	Members of the owner not individually liable
GC-26	Owner not bound by personal representations
GC-27	Contractor's office at site
GC-28	Contractor's subordinate staff and their conduct
GC-29	Termination of sub-contract by owner
GC-30	Power of entry
GC-31	Contractor's responsibility with the other Contractor and Agencies.
GC-32	Other Agencies at site
GC-33	Notices
GC-34	Rights of various interests
GC-35	Price adjustments
GC-36	Terms of Payment
GC-37	Retention Money
GC-38	Payments due from the Contractor
GC-39	Contingent Fee
GC-40	Breach of Contract by Contractor
GC-41	Default of Contractor
GC-42	Bankruptcy
GC-43	Ownership
GC-44	Declaration against waiver
GC-45	Laws governing the contract
GC-46	Over payment and under payment

GC-47	Settlement of disputes
GC-48	Disputes of differences to be referred to
GC-49	DELETED
GC-50	Termination of the Contract
GC-51	Special risks
GC-52	Change in Constitution
GC-53	Sub-contractual relations
GC-54	Patents and Royalties
GC-55	Lien
GC-56	Execution of work
GC-57	Work in monsoon
GC-58	Work on Sundays and Holidays
GC-59	General Conditions for construction work
GC-60	Drawings to be supplied by the Owner
GC-61	Drawings to be supplied by the Contractor
GC-62	Setting outwork
GC-63	Responsibilities of Contractor for correctness of work
GC-64	Materials to be supplied by the Owner
GC-65	Conditions of issue of materials by the Owner
GC-66	Materials procured with assistance of the Owner
GC-67	Materials obtained from dismantling
GC-68	Article of value of treasure found during construction
GC-69	Discrepancies between instructions
GC-70	Alternations in specifications and designs and extra work.
GC-71	Action when no specifications are issued
GC-72	Abnormal rates
GC-73	Assistance to Engineer-In-Charge
GC-74	Tests for quality of work
GC-75	Action and compensation in case of bad workmanship
GC-76	Suspension work
GC-77	Owner may do part of the work
GC-78	Possession prior to completion
GC-79	Completion Certificate
GC-80	Schedule of Rates
GC-81	Procedure for measurement of work in progress
GC-82	Running account payments to be regarded as advances
GC-83	Notice for claim for additional payment
GC-84	Payment of Contractor's Bill
GC-85	Final Bill
GC-86	Receipt for payment
GC-87	Completion Certificate
GC-88	Taxes, Duties, etc.
GC-89	Insurance
GC-90	Damage to Property
GC-91	Contractor to Indemnify Owner
GC-92	Implementation of Apprentice Act 1954
GC-93	Health and Sanitary arrangements for workers
GC-94	Safety Code
GC-95	Accidents

GC-01 DEFINITIONS AND INTERPRETATIONS :

- 1.0 In the contract (as hereinafter defined) the following words and expressions shall, unless repugnant to the subject or context thereof, have the following means as signed to them.
- 1.1 The "Owner / Corporation" shall mean Rajkot Municipal Corporation and shall include its Municipal Commissioner or other Officers authorized by the Corporation and also include owner's successors and assignees.
- 1.2 The "Contractor" shall mean the person or the persons, firm or Company whose e-Tender has been accepted by the Owner and includes the Contractors legal representative, his successors and permitted assigned.
- 1.3 The "Engineer-In-Charge" shall mean the person designated as such by the owner from time to time and shall include those who are expressly authorized by the Corporation to act for and on its behalf for all functions pertaining to the operation of this contract.
- 1.4 Engineer-In-Charge's Representative shall mean any resident Engineer or Assistant to the Engineer-In-Charge appointed from time to time by the owner to perform duties set forth in the e-TENDER Document whose authority shall be notified in writing to the Contractor by the Engineer-In-Charge.
- 1.5 "e-TENDER" – the offer or proposal of the Tenderer submitted in the prescribed form setting for the prices for the work to be performed, and the details thereof.
- 1.6 "Contract Price" shall mean total money payable to the Contractor under the contract.
- 1.7 "Addenda" shall mean the written or graphic notices issued prior to submission of e-Tender which modify or interpret the contract documents.
- 1.8 "Contract Time" – the time specified for the completion of work.
- 1.9 "Contract" shall mean agreement between the parties for the execution of works including therein all contract documents.
- 1.10 "Contract Document" shall mean collectively the e-Tender documents, designs, drawings, specifications, agreed variations, if any and such other documents constituting the e-Tender and acceptance thereof.
- 1.11 "The Sub-Contractor" shall mean any person, firm or company (other than the Contractor) to whom any part of the work has been entrusted by the Contractor with the written consent of the Engineer-In-Charge and the legal representative successors and permitted assignee of such person, firm or company.

- 1.12 The "Specifications" shall mean all directions, the various Technical Specifications, provisions and requirements attached to the contract which pertains to the method and manner of performing the work, to the quantities and qualities of the work and the materials to be furnished under the contract for the work and any order(s) or instruction(s) there under. It shall also mean the latest Bureau of Indian standard Specification relative to the particular work or part thereof, so far as they are not contrary to the e-TENDER specifications and in absence of any other Country applied in Indian as a matter of standard engineering practice and approved in writing by the Engineer-In-Charge with or without modification.
- 1.13 The "Drawings" shall include maps, plans, tracings, or prints thereof with any modification approved in writing by the Engineer-In-Charge and as such other drawings as may, from time to time, be furnished or approved in writing by the Engineer-In-Charge in connection with the work.
- 1.14 The "Work" shall mean the works to be executed in accordance with the contract or the part thereof as the case may be and shall include extra, additional, altered or substituted works as required for the purpose of the contract. It shall mean the totality of the work by expression or implication envisaged in the contract and shall include all materials, equipment and labour required for or relative or incidental to or in connection with the commencement, performance and completion of any work and / or incorporation in the work.
- 1.16 The "Permanent Work" shall mean works which will be incorporated in and form part of the work to be handed over to the owner by the Contractor on completion of the contract.
- 1.17 The "Temporary Work" shall mean all temporary works of every kind required in or about the execution, completion and maintenance of the work.
- 1.18 "Site" shall mean the land and other places, on, under, in or through which the permanent works are to be carried out and any other lands or places provided by the Corporation for the purpose of the contract together with any other places designated in the contract as forming part of the site.
- 1.19 The "Construction Equipment" shall mean all appliances / equipment of whatever nature required in or for execution, completion or maintenance of works or temporary works (as herein before defined) but does not include materials or other things intended to form or forming part of the permanent work.
- 1.20 "Notice in writing or written Notice" shall mean a notice written, typed or in printed form delivered personally or sent by Registered Post to the last known private or business address or Registered Office of the Contractor or through E-mail or Mobile message on the Mobile of contractor shall be deemed to have been received in the ordinary course of post it would have been delivered.

- 1.21 The "Alteration / variation order" shall mean an order given in writing by the Engineer-In-Charge to effect additions or deletions from or alterations in the work.
- 1.22 "Final Test Certificate" shall mean the final test certificate issued by the owner within the provisions of the contract.
- 1.23 The "Completion Certificate" shall mean the certificate to be issued by the Engineer-In-Charge when the work has been completed and tested to his satisfaction.
- 1.24 The "Final Certificate" shall mean the final certificate issued by the Engineer-In-Charge after the period of defects liability is over and the work is finally accepted by the owner.
- 1.25 "Defects Liability Period" shall mean the specified period between the issue of Completion Certificate and the issue of final certificate during which the Contractor is responsible for rectifying all defects that may appear in the works.
- 1.26 "Approved" shall mean approved in writing including subsequent confirmation in writing of previous verbal approval and "Approval" means approved in writing including as aforesaid.
- 1.27 "Letter of Acceptance" shall mean intimation by a letter to Tenderer that his e-Tender has been accepted in accordance with the provisions contained therein.
- 1.28 "Order" and "Instructions" shall respectively mean any written order or instruction given by the Engineer-In-Charge within the scope of his powers in terms of the contract.
- 1.29 "Running Account Bill" shall mean a bill for the payment of "On Account" money to the Contractor during the progress of work on the basis of work done and the supply of non-perishable materials to be incorporated in the work.
- 1.30 "Security Deposit" shall mean the deposit to be held by the owner as security for the due performance of the contractual obligations.
- 1.31 The "Appointing Authority" for the purpose of Arbitration shall be the Municipal Commissioner, Rajkot Municipal Corporation.
- 1.32. "Retention Money" shall mean the money retained from R.A.Bills for the due completion of the "LET WORKS".
- 1.33 Unless otherwise specifically stated, the masculine gender shall include the feminine and neuter genders and vice-versa and the singular shall include the plural and vice-versa.

GC-02 LOCATION OF SITE AND ACCESSIBILITY:

The work is to be carried out in city area and parallel to the State Highway. Non-availability of access roads shall in no case be the cause to condone delay in the execution of the work and no claim or extra compensation will be paid. Also work is to be carried out in residential area and as such excavation will be carried out in hard rock with controlled blasting and at low charge.

GC-03 SCOPE OF WORK:

The scope of work is defined broadly in the special conditions of contract and specifications. The Contractor shall provide all necessary materials, equipment and labor etc. for the execution and maintenance of the work. All material that go with the work shall be approved by the Engineer-In-Charge prior to procurement and use.

Power Supply :

The Contractor shall make his own arrangement for power supply during installation.

Land for Contractor's Field Office, Go down Etc.:

Owner will not be in a position to provide land required for Contractor's field office, go down, etc. The Contractor shall have to make his own arrangement for the same.

GC-04 RULING LANGUAGE:

The language according to which the contract shall be construed and interpreted shall be English. All entries in the contract document and all correspondence between the contractor and the Corporation or the Engineer-In-Charge shall be in English/Gujarati. The Correspondence language during finalizing tender & execution of work shall be in English or Gujarati. All dimensions for the materials shall be given in metric units only.

GC-05 INTERPRETATION OF CONTRACT DOCUMENT:

1. The provision of the General Conditions of Contract and Special Conditions of Contract shall prevail over those of any other documents of the contract unless specifically provided otherwise, should have there be any discrepancy, inconsistency, error or omission in the several documents forming the contract, the matter may be referred to the Engineer-In-Charge for his instructions and decision. The Engineer-In-Charge's decision in such case shall be final and binding to the Contractor.
2. Works shown upon the drawings but not described in the specifications or described in the specifications without showing on the drawings shall be taken as described in the specifications and shown on the drawings.
3. The headings and the marginal notes to the clause of these General Conditions of Contract or to the specifications or to any other part of e-Tender documents are solely for the purpose of giving a concise indication and not a summary of contents thereof. They shall never be deemed to be part thereof or be used in the interpretation or construction of the contract.

4. Unless otherwise states specifically, in this contract documents the singular shall include the plural and vice-versa wherever the context so requires. Works imparting persons shall include relevant Corporations / Body of individual / firm of partnership.
5. Notwithstanding the sub-division of the documents into separate section and volumes every part of each shall be supplementary to and complementary of every other part and shall be read with and into the context so far as it may be practicable to do so.
6. Where any portion of the General Conditions of Contract is repugnant to or at variance with any provisions of the Special Conditions of Contract, then, unless a different intention appears, the provisions of the special conditions of contract shall be deemed to over ride the provisions of General Conditions of Contract to the extent of each repugnancy of variance.
7. The materials, design, and workmanship shall satisfy the relevant ISS, and codes referred to. If additional requirements are shown in the specifications, the same shall be satisfied over and above ISS and other codes.
8. If the specifications mention that the Contractor shall perform certain work or provide certain facilities, it shall mean that the Contractor shall do so at his own cost.
9. Contractor to Collect His Own Information -
The details given in the e-Tender are arranged making necessary investigations for framing an estimate. However, when the work is being executed, changes in soil conditions are likely to be met with in view of the formation of soil, strata in Rajkot District. It is, therefore, desirable that the Contractor makes his own investigations or additional investigations as may be required for correctly assessing the cost of different items of work and submit his e-Tender accordingly. Any change in description or quantity of an item shall not vitiate the contract or release the Contractor from executing the work comprised in the contract according to the drawings and specifications at the e-Tendered rates.

He is deemed to have know the scope, nature and magnitude of the work and the requirements of materials and labour involved and as to whatever work he has to complete in accordance with the contract. The Contractor is expected to visit the site and surroundings to satisfy himself as to the nature of all existing structures, if any, and also as to the nature and the conditions of railways, roads, bridges and culverts, means of transport and communications whether by land, air or water and as to possible interruptions thereto and the access and gross from the site, to have examined and satisfied himself as to the sites for obtaining sand, stones, bricks and other materials, the site for disposal of surplus materials, the available accommodation and make such

enquiries as may be necessary for executing and completing the work, to have local enquiries as to the sub-soil, subsoil water and variation thereof, storms, prevailing winds, climatic conditions and all other similar matters, effecting work. He is expected to be familiar with his liability for payment of Government taxes, customs and excise duty and other charges etc. in contract with the execution of this contract.

- GC-06 **CONTRACTOR TO UNDERSTAND HIMSELF FULLY :**
The Contractor by e-Tendering shall be deemed to have satisfied himself, as to all considerations and circumstances affecting the e-Tender price, as to the possibility of executing the works as shown and described in the contract and to have fixed his prices according to his own view on these matters and to have understood that no additional allowances except as otherwise expressly provided, will afterwards be made beyond the contract price. The Contractor shall be responsible for any misunderstanding or incorrect information, however, obtained.
- GC-07 **ERRORS IN SUBMISSIONS :**
The Contractor shall be responsible for any errors or omissions in the particulars supplied by him, whether such particulars have been approved by the Engineer-In-Charge or not.
- GC-08 **SUFFICIENCY OF e-Tender :**
The Contractor shall be deemed to have satisfied himself before e-Tendering as to the correctness of the e-Tender rates which rates shall, except as otherwise provides for, cover all the Contractor's liabilities and obligations set forth or implied in the contract for the proper execution of the work for compliance with requirements of Article GC-19 thereof.
- GC-09 **DISCREPANCIES :**
The drawings and specifications are to be considered as mutually explanatory of each other, detailed drawings being followed in preference to small-scale drawings and figured dimensions in preference to scale and special conditions in preference to General Conditions. The special directions or dimensions given in the specifications shall supercede all else. Should any discrepancies however, appear or should any misunderstanding arise as to the meaning and intent of the said specifications or drawings, or as to the dimensions or the quality of the materials or the due and proper execution of the works, or as to the measurement or quality and valuation of the work executed under this contract or as extra there upon, the same shall be explained by the Engineer-In-Charge and his explanation shall be subject to the final decision of the Municipal Corporation in case reference be made to it, be binding upon the Contractor and the Contractor shall execute the work according to such explanation and without addition or to deduction from the contract price and shall also do all such works and things necessary for the proper completion of the works as implied by the drawings and specifications, even though such works and things are not

specially shown and described in the said specifications. In cases where no particular specifications are given for any article to be used under the contract, the relevant specifications of the Indian Standard Institution shall apply.

GC-10 PERFORMANCE GUARANTEE (SECURITY DEPOSIT):

1. As a contract security the Tenderer to whom the award is made shall furnish a performance guarantee (Security deposit) for the amount of 5% of the contract price to guarantee the faithful performance, completion and maintenance of the works of the contract in accordance with all conditions and terms specified herein and to the satisfaction of the Engineer-in-charge and ensuring the discharge of all obligations arising from the execution of contract in the forms mentioned below:
 - a. By a Demand Draft on the Rajkot Branch of any Nationalized Bank in India.
 - b. A Fixed Deposit Receipt of a Nationalized Bank duly endorsed in favour of the "RAJKOT MUNICIPAL CORPORATION", Rajkot.

The above DD or FDR shall be delivered to the Corporation within ten (10) days of the notice of award and at least three (3) days before the contract agreement is signed unless otherwise specified by the Engineer- in-charge. Alternatively, the contractor may at his option deposit an amount of 2.5% of the value of the contract price within ten days and the balance 2.5% to be recovered in installments through deduction @ the rate of 10% from the running account bills.

Bank Guarantee will not be accepted for this purpose.

On due performance and completion of the contract in respects, the performance guarantee will be returned to the contractor without any interest after the defect liability period is over.

2. If the Contractor, sub-contractor or their employees shall break, deface or destroy any property belonging to the owner or other agency during the execution of the contract, the same shall be made good by the contractor at his own expense and in default thereof, the Engineer-In-Charge may cause the same to be made good by other agencies and recover expense from the Contractor (for which the certificate of the Engineer-In-Charge shall be final). These expense can be recovered from the security deposit if recovery from other sources is not possible. The amount as reduced in security deposit will be made good by deduction from the next R A Bill of the Contractor.

GC-11 INSPECTION OF WORK :

1. The Engineer-In-Charge shall have full power and authority to inspect the work at any time wherever in progress either on the site or at the Contractor's or any other manufacturer's workshop or

factories wherever situated and the Contractor shall afford to Engineer-In-Charge every facility and assistance to carry out such inspection. Contractor or his authorized representative shall, at all time during the usual working hours and all times when so notified, remain present to receive orders and instructions.

Orders given to Contractor's representative shall be considered to have the same force as if they had been given to the Contractor himself. Contractor shall give not less than ten (10) days notice in writing to the Engineer-In-Charge before covering up or otherwise placing beyond reach of inspection and measurement any work in order that the same may be inspected and measured. In the event of breach of the above, the same shall be uncovered at Contractor's expenses for carrying out such inspection or measurement.

2. The material shall be dispatched from Contractor's store on site of work after obtaining approval in writing of the Engineer-In-Charge. Contractor shall provide at all times during the progress of work and maintenance period of proper means of access with ladders, gangways, etc. and make necessary arrangement as directed for inspection or measurement of work by Engineer-In-Charge.

GC-12 DEFECT LIABILITY:

1. Contractor shall guarantee the work for a period of 12 months from the date of issue of Completion Certificate. Any damage or defect that may arise or that may remain undiscovered at the time of issue of Completion Certificate connected in any way with the equipment or materials supplied by him or in the workmanship shall be rectified or replaced by Contractor at his own expense as desired by Engineer-In-Charge or in default Engineer-In-Charge may cause the same to be made good by other agency and deduct expenses of which the certificate of Engineer-In-Charge shall be final from any sums that may then or any time thereafter become due to Contractor or from his security deposit or the proceeds of sale thereof or of a sufficient portion thereof.
2. From the commencement to completion of work Contractor shall take full responsibility for the care of the work including all temporary works and in case any damages, occur from any cause whatsoever he shall at his own cost, repair and make good the same so that on completion, work shall be in good order and in conformity, in every respect, with the requirements of contract and as per the instructions of the Engineer-In-Charge.
3. If at any time before the work is taken over, the Engineer-In-Charge -
 - a) Decide that any work done or materials used by the Contractor are defective or not in accordance with the contract or that work or any portion thereof is defective or do not fulfill the requirements of contract (all such materials being herein after called defects in this clause) he shall, as soon as reasonably

practicably, give notice to Contractor in writing of the said defect specifying particulars of the same then Contractor shall at his own expense and with all speed make good the defects so specified.

- b) In case Contractor fails to do so, owner may take, at the cost of the Contractor, such steps as may in all circumstances be responsible to make good such defects. The expenditure so incurred by owner will be recovered from the amount due to Contractor. The decision of Engineer-In-Charge with regard to the amount to be recovered from Contractor will be final and binding on the Contractor.

GC-13 POWER OF ENGINEER-IN-CHARGE TO GIVE FURTHER INSTRUCTIONS:

The Engineer-In-Charge shall have the power and authority from time to time and at all times to give further instructions and directions as may appear to him necessary or proper for the guidance of the Contractor and the works and efficient execution of the works according to the terms of the specifications, and the Contractor shall receive, execute, obey and be bound by the same, according to the true intent and meaning thereof, as fully and effectively as though the same had accompanied or had been mentioned or referred to in the specifications. No work which radically changes the original nature of the contract shall be ordered by the Engineer-In-Charge and in the event of any deviation being ordered, which in the opinion of the Contractor changes the original nature of the contract, he shall nevertheless carry it out and any disagreement as to the nature of the work and the rate to be paid to thereof shall be resolved.

The time of completion of works shall, in the event of any deviations being ordered resulting in additional cost or reduction in cost over the contract sum, be extended or reduced reasonably by the Engineer-In-Charge. The Engineer-In-Charge's decision in the case shall be final and binding.

GC-14 PROGRAMME:

The time allowed for execution of works shall be the essence of the contract. The contract period shall commence from the date of notice of intimation to proceed. The Tenderer at the time of submitting his e-Tender shall indicate in the construction schedule his programme of execution of work commencement with the total time specified. The Contractor shall provide the Engineer-In-Charge a detailed programme of time schedule for execution of the works in accordance with the specifications and the completion date. The entire programme to be finalized by the Contractor, has to conform to the execution period mentioned along with the Bill of Quantities in the e-Tender documents. The Engineer-In-Charge upon scrutiny of such submitted programme by Contractor, shall examine suitability of it to the requirement of contract and suggest modifications, if found necessary.

GC-15 SUB-LETTING OF WORK:

No part of the contract nor any share of interest thereon shall in any manner or degree be transferred, assigned or sublet by the Contractor directly or indirectly to any person, firm or Corporation whosoever except as provided for in the succeeding sub-clause, without the consent in writing of the owner.

GC-16 SUB-CONTRACTS FOR TEMPORARY WORKS ETC. :

The owner may give written consent to sub-contractors for execution of any part of the works at the site, being entered upon the contractor provided each individual contract is submitted to the Engineer-In-Charge before being entered into and is approved by him. List of sub-contractors to be supplied.

Notwithstanding any subletting with such approval as aforesaid and notwithstanding the Engineer-In-Charge shall have received of any sub-contractors, the Contractor shall be and shall remain solely responsible for the quality and proper and expeditious execution of the works and the performance of all the conditions of contract in all respects as if such subletting or subcontracting had not taken place and as if such works had been done directly by the Contractor.

GC-17 TIME FOR COMPLETION:

1. The work covered under this contract shall be commenced from the date the Contractor is served with a notice to proceed with the work and shall be completed before the date as mentioned in the time schedule of work. The time is the essence of the contract and unless the same is extended as mentioned in Clause GC-18 "Extension of Time", the Contractor shall pay liquidated damages for the delay.
2. The general time schedule for construction is given in the e-Tender document. Contractor shall prepare a detailed weekly or monthly construction programme in consultation with the Engineer-In-Charge soon after the agreement and the work shall be strictly executed accordingly.

The time for construction includes, the time required for testing, rectifications, if any, retesting and completion of the work in all respects to the entire satisfaction of the Engineer-In-Charge except the items which are not coming in the way to commission the project.

3. Monsoon period from 1st July to 30th September shall be considered as non-working period hence excluded in time limit.

- GC-18 **EXTENSION OF TIME:**
Time shall be considered as the essence of the contract. If, however, the failure of the Contractor to complete the work as per the stipulated dates referred to above arises from delays on the part of Corporation in supplying the materials or equipment, it has undertaken to supply under the contract or from delays on the quantity of work to be done under the contract, or force majeure an appropriate extension of time will be given by the Corporation. The Contractor shall request for such extension within one month of the cause of such delay and in any case before expiry of the contract period.
- GC-19 **CONTRACT AGREEMENT:**
The successful Tenderer shall enter into and execute the contract agreement within 20 (Twenty) days of the notice of award, in the form shown in e-Tender documents with such modifications as may be necessary in the opinion of the Corporation. It shall be incumbent on the Contractor to pay the stamp duty and the legal charges for the preparation of the contract agreement.
- GC-20 **LIQUIDATED DAMAGES:**
If the Contractor fails to complete the work or designated part thereof within the stipulated completion date for the work or for the part, he shall pay liquidated damages at 0.1 (zero point one) percent of contract value for per day of delay subject to maximum of 10% of the contract value or as decided by Municipal Commissioner.
- The Contractor shall complete one-sixth quantum of work within one fourth period, four-tenth quantum of work within one-half period and eight-tenth quantum of work within three-fourth period, failing which, the Contractor shall be liable to pay liquidated damages an amount as specified above, or as decided by Municipal Commissioner.
- The amount of liquidated damages shall, however, be subjected to a maximum of 10 percent of the contract value.
- GC-21 **FORFEITURE OF SECURITY DEPOSIT:**
Whenever any claim against the Contractor for the payment of a sum of money out of or under the contract arises, the Corporation shall be entitled to recover such sum by appropriating in part or whole, the security deposit of the Contractor. In case the security deposit is insufficient, the balance recoverable shall be deducted from any sum then due or which at any time thereafter may become due to the Contractor. The Contractor shall pay to the owner on demand any balance remaining due.

GC-22 ACTION OF FORFEITURE OF SECURITY DEPOSIT:

In any case in which under any Clause or Clauses of the contract, the Contractor shall committed a breach of any of the terms contained in this contract, the owner shall have power to adopt any of the following courses as he may deem best suited to his interest.

- a) To rescind the contract (of which recession notice in writing to the contractor under the hand of the owner shall be conclusive evidence) in which case the security deposit of the Contractor shall stand forfeited and be absolutely at the disposal of the owner.
- b) To employ labour and to supply materials to carry out the balance work debiting Contractor with the cost of labour employed and the cost of materials supplied for which a certificate of the Engineer-In-Charge shall be final and conclusive against the Contractor and 10% of costs on above to cover all departmental charges and crediting him with the value of work done at the same rates as if it has been carried out by the Contractor under the terms of his contract. The certificate of Engineer-In-Charge as to the value of the work done shall be final and conclusive against the Contractor.
- c) To measure up the work of the contractor and to take such part thereof as shall be unexecuted out of his hand and give it to another Contractor to complete, the same. in this case the excess expenditure incurred than what would have been paid to the original Contractor, if the whole work had been executed by him, shall be borne and paid by the original Contractor and shall be deducted from any money due to him by the owner under the contract or otherwise and for the excess expenditure, the certificate of the Engineer-In-Charge shall be final and conclusive.

In the event any of the above courses being adopted by the owner, the Contractor shall have no claims for compensation for any loss sustained by him by reason of his having purchased or procured any materials or entered into any agreements or made any advance on account of or with a view to the execution of the work or the performance of the contract.

In purchase the Contractor shall not be entitled to recover or be paid any sum for any work actually performed under this contract unless the Engineer-In-Charge will certify in writing the performance of such work and the value payable in respect thereof and he shall only be entitled to be paid the value so certified.

In the event of the owner putting in force the powers as stated in a, b, c, above vested in him under the proceeding clause, he may, if he so desires, take possession of all or any tools and plant, materials and stores in or upon the works or the site thereof belonging to the Contractor, or procured by him and intended to be

used for the execution of the work or any part thereof paying or allowing for the same in account at the contract rates to be certified by the Engineer-In-Charge. The Engineer-In-Charge may give notice in writing to the Contractor or his representative requiring him to remove such tools, plant, materials or stores from the premises within the time specified in the notice and in the event of the Contractor failing to comply with any such notice, the Engineer-In-Charge may remove them at the Contractor's expenses or sell them by auction or private sale on account of the Contractor and his risks in all respects without any further notice as to the date, time or place of the sale and the certificate of Engineer-In-Charge as to the expense of any such removal and the amount of the proceeds and the expenses of any such sale shall be final and conclusive against the Contractor.

GC-23 COMPENSATION FOR ALTERATION IN OR RESTRICTION IN WORK:

If at any time from the commencement of the work, the owner shall for any reasons whatsoever not require the whole work or part thereof as specified in the e-Tender to be carried out, the Engineer-In-Charge shall give notice in writing of the fact to the Contractor, who shall have no claim to any payment or compensation whatsoever on account of any profit or advantage which he might have derived from the execution of the work in full but which he did not derive in consequence of full amount of the work not having been carried out. He also shall not have any claim for compensation by reasons of any alterations having been made in original specifications, drawings, designs and instructions which shall involve any curtailment of the work as originally contemplated.

When the Contractor is a partnership firm, the prior approval in writing of the owner shall be obtained before any change is made in the Constitution of the firm. Where the Contractor is an individual or a Hindu Undivided Family or business concern, such approval as aforesaid shall, likewise be obtained before Contractor enters into an agreement with other parties where under, the reconstituted firm would have the right to carry out the work hereby undertaken by the Contractor. In either case, if prior approval as aforesaid is not obtained, the contract shall be deemed to have been allotted contravention of subletting clause hereof and the same action may be taken and the same consequence shall ensure as provided in the subletting clause.

GC-24 IN THE EVENT OF DEATH OF THE CONTRACTOR :

Without prejudice to any of the rights or remedies under the contract, if the Contractor dies, the owner shall have the option of terminating the contract without compensation to the Contractor.

- GC-25 MEMBERS OF THE OWNER NOT INDIVIDUALLY LIABLE:
No official or employee of the owner shall in any way be personally bound or liable for the acts or obligation of the owner under the contract, or answerable for any default or omission in the observance or performance of any acts, matters or things, which are herein, contained.
- GC-26 OWNER NOT BOUND BY PERSONAL REPRESENTATIONS:
The Contractor shall not be entitled to any increase on the schedule of rates or any other rights or claims whatsoever by reason of representation, promise or guarantees given or alleged to have been given to him by any person.
- GC-27 CONTRACTOR'S OFFICE AT SITE:
The Contractor shall provide and maintain an office at the site for the accommodation of his agent and staff and such office shall remain open at all reasonable hours to receive information, notices or other communications.
- GC-28 CONTRACTOR'S SUBORDINATE STAFF AND THEIR CONDUCT:
1. The Contractor on award of the work shall name and depute a qualified Engineer having experience of carrying out work of similar nature, whom equipment, materials, if any, shall be issued and instructions for work given. The Contractor shall also provide to the satisfaction of Engineer-In-Charge sufficient and qualified staff, competent sub-agents, foreman and loading hands including those specially qualified by previous experience to supervise the type of works comprised in the contract in such manner as will ensure work of the best quality and expeditious working. If, in the opinion of the Engineer-In-Charge additional properly qualified supervision staff is considered necessary, it shall be employed by the Contractor, without additional charge on account thereof. The Contractor shall ensure to the satisfaction of the Engineer-In-Charge that sub-contractors, if any, shall provide competent and efficient supervision over the work entrusted to them.
 2. If and whenever any of the Contractor's or sub-contractor's agents, sub-agents, assistants, foreman or other employees shall, in the opinion of the Engineer-In-Charge, be guilty of any misconduct or be incompetent or insufficiently qualified or negligent in the performance of their duties or that in the opinion of the owner or Engineer-In-Charge, it is undesirable for administrative or any other reason for person or persons to be employed in the works, the Contractor if so directed by the Engineer-In-Charge, shall at once remove such person or persons from employment thereon. Any person or persons so removed shall not again be re-employed in connection with the works without the written permission of the Engineer-In-Charge. Any person, so removed from the works shall be immediately replaced at the expense of the Contractor by a qualified and competent substitute. Should the Contractor be required to repatriate any person removed from the works he shall

do so after approval of Engineer-In-Charge and shall bear all costs in connection therewith.

3. The Contractor shall be responsible for the proper behavior of all the staff, foreman, workmen and others and shall exercise proper control over them and in particular and without prejudice to the said generality, the Contractor shall be bound to prohibit and prevent any employee from trespassing or acting in any way detrimental or prejudicial to the interest of the community or of the properties or occupiers of land and properties in the neighborhood and in the event of such employees so trespassing, the Contractor shall be responsible therefore and relieve the owner of all consequent claims, actions for damages or injury or any other ground whatsoever. The decision of the Engineer-In-Charge upon any matter arising under this claim shall be final.
4. If and when required by the owner, the Contractor's personnel entering upon the owner's premises shall be properly identified by badges of a type acceptable to the owner which must be worn at all times on owner's premises.

GC-29 TERMINATION OF SUB-CONTRACT BY OWNER:

If any sub-contractor engaged upon the works at the site execute any work which in the opinion of Engineer-In-Charge is not accordance with the contract documents, the owner may by written notice to the Contractor request him to terminate such sub-contract and the Contractor upon the receipt of such notice shall terminate such sub-contracts and the latter shall forthwith leave the works, failing which, the owner shall have the right to remove such sub-contractors from the site.

No action taken by the owner under the above clause shall relieve the Contractor of his liabilities under the contract or give rise to any right to compensation, extension of time or otherwise.

GC-30 POWER OF ENTRY:

If the Contractor shall not commence the work in the manner previously described in the contract documents or if he shall at any time, in the opinion of Engineer-In-Charge –

- (i) Fail to carry out works in conformity with the contract documents, or
- (ii) Fail to carry out the works in accordance with the time schedule, or
- (iii) Substantially suspend work or the works for a period of seven days without authority from Engineer-In-Charge, or
- (iv) Fail to carry out and execute the work to the satisfaction of the Engineer-In-Charge, or
- (v) Fail to supply sufficient or suitable construction plant, temporary works, labour, materials or things, or
- (vi) Commit breach of any other provisions of the contract on his part to be performed or observed or persists in any of

the above mentioned breaches of the contract for seven days after notice in writing shall have been given to the Contractor by the Engineer-In-Charge requiring such breach to be remedied, or

- (vii) Abandon the work, or
- (viii) During the continuance of the contract becomes bankrupt, make any arrangement or compromise with his creditors, or permit any execution to be levied or go into liquidation whether compulsory or voluntary not being merely a voluntary liquidation for the purpose of amalgamation or reconstruction then in any such case.

The owner shall have the power to enter upon the works and take possession thereof and of the materials, temporary works, constructional plant and stores therein and to revoke the Contractor's license to use the same and to complete the works by his agents, other Contractor or workmen, to relate the same upon any terms to such other person firm or Corporation as the owner in his absolute discretion may think proper to employ, and for the purpose aforesaid to use or authorize the use of any materials, temporary works, constructional plant, and stores as aforesaid with making payments or allowance to the Contractor for the said materials other than such as may be certified in writing by the Engineer-In-Charge to be reasonable and without making any payment or allowance to the Contractor for the use of said temporary works, constructional plant and stock or being liable for loss or damage thereto. If the owner shall be reason of his taking possession of the works or of the work being got completed by other Contractor incurred excess expenditure be deducted from any money which may be due for the work done by the Contractor under the contract and not paid for. Any deficiency shall forthwith be made good and paid to the owner by the Contractor and the owner shall have power to sell in such manner and for such price as he may think fit all or any of the constructional plant, materials etc., consist constructed by or belonging to and to recoup and retain the said deficiency or any part thereof out of the proceeds of the sale.

GC-31 CONTRACTOR'S RESPONSIBILITY WITH THE OTHER CONTRACTOR AND AGENCIES:

Without repugnance to any other conditions, it shall be the responsibility of the Contractor executing the work, to work in close co-operation and co-ordination with other Contractors or their authorized representatives and the Contractor will put a joint scheme with the concurrence of other contractors or their authorized representatives showing the arrangements for carrying his portion of the work to the Engineer-In-Charge and get the approval. The Engineer-In-Charge before approving the joint scheme will call the parties concerned and modify the scheme if required. No claim will be entertained on account of the above. The Contractor shall conform in all respects with the provisions of any statutory regulations, ordinances or bylaws of any local or duly

constituted authorities or public bodies which may be applicable from time to time to works or any temporary works. The Contractors shall keep the owner indemnified against all penalties and liabilities of every kind arising out of non-adherence to such statutes, ordinance, laws, rules, regulations etc.

GC-32 OTHER AGENCIES AT SITE:

The Contractor shall have to execute the work in such place and condition where other agencies will also be engaged for other works, such as site grading, filling and leveling, electrical and mechanical engineering works etc. No claim shall be entertained for works being executed in the above circumstances.

GC-33 NOTICES:

Any notice under this contract may be served on the Contractor or his duly authorized representative at the job site or may be served by Registered Post direct to the official address of the Contractor. Proof of issue of any such notice could be conclusive of the Contractor having been duly informed of all contents therein.

GC-34 RIGHTS OF VARIOUS INTERESTS:

The owner reserves the right to distribute the work between more than one Contractor. Contractor shall co-operate and afford reasonable opportunity to other Contractors for access to the works, for the carriage and storage of materials and execution of their works. Whenever the work being done by department of the owner or by other Contractor employed by the owner is contingent upon work covered by this contract, the respective rights of the various interests shall be determined by the Engineer-In-Charge to secure the completion of various portions of the work in general harmony.

GC-35 PRICE ADJUSTMENTS:

No adjustment in price shall be allowed and no price escalation will be allowed.

GC-36 TERMS OF PAYMENT:

The payment of bills shall be made progressively according to the rules and practices followed by the Corporation. The progressive payment unless otherwise provided in the contract agreement or subsequently agreed to by the parties shall be made generally monthly on submission of a bill by the Contractor in prescribed form of an amount according to the value of the work performed less the price of materials supplied by owner, aggregate of previous progressive payments and as required by Clause GC-37 (Retention of Money) herein. All such progressive payments shall be regarded as payments by way of advance against final payment. Payment for the work done by the Contractor will be based on the measurement at various stages of the work, in accordance with the condition at clause GC-81 (measurement of work in progress).

GC-37 RETENTION MONEY:

- i) Pursuance to clause GC-36 (Terms of Payment) any on at money due to the Contractor for work done, the Corporation will retain Five (5) Percent of ' gross R.A. Bill amount as retention amount as mentioned in Clause GC-82 (Running Account Payments) and same shall be paid with the final bill.

GC-38 PAYMENTS DUE FROM THE CONTRACTOR:

All costs, damages or expenses, for which under the contract, Contractor is liable to the Corporation, may be deducted by the Corporation from any money due or becoming due to the Contractor under the contract or from any other contract with the Corporation or may be recovered by action at law or otherwise from the Contractor.

GC-39 CONTINGENT FEE:

- i) The Contractor warrants that he has not employed a person to solicit or secure the contract upon any agreement for a commission, percentage, and brokerage contingent fee. Breach of this warranty shall give the Corporation the right to cancel the contract or to take any drastic measure as the Corporation may deem fit. The warranty does not apply to commissions payable by the Contractor to establish commercial or selling agent for the purpose of securing business.
- ii) No officer, employer or agent of the Corporation shall be admitted to any share or part of this contract or to any benefit that may rise there from.

GC-40 BREACH OF CONTRACT BY CONTRACTOR:

If the Contractor fails to perform the work under the contract with due diligence or shall refuse or neglect to comply with instructions given to him in writing by the Engineer-In-Charge in accordance with the contract, or shall contravene the provisions of the contract, Deputy Executive Engineer or his higher authority becomes competent authority on behalf of the Corporation may give termination notice in writing to the Contractor to make good such failure, neglect, or contravention. Should the Contractor fail to comply with such written notice within 14 (fourteen) days of receipt, it shall be lawful for the Corporation, without prejudice to any other rights the Corporation may have under the contract, to terminate the contract for all or part of the works, and make any other arrangements it shall deem necessary to complete the work outstanding under the contract at the time of termination and contractor shall be Black Listed / Debarred from the work of RMC for the period of three years. In this event, the performance Bond, Security Deposit or any other extra Security Deposit shall be forfeited and immediately become due and payable to the Corporation.

The value of the work done on the date of termination and not paid for shall be kept as deposit for adjustment of excess expenditure incurred in getting the remaining work completed and the Corporation shall have free use of any works which the Contractor may have at the site at the time of termination of the

contract.

For all this procedures like to issue termination order, to issue forfeiting orders etc. City Engineer or Equivalent becomes competent authority.

If Contractor fails to carry out the work in timely manner as mentioned in GC-20, Rajkot Municipal Corporation may give notice in writing to the Contractor to expedite the progress of work, so that the work can be completed as per time schedule. If Contractor fails to expedite the progress of work within 14 days, Rajkot Municipal Corporation will forfeit the Earnest Money Deposit and may terminate the contract and put the Contractor in Black List / Debar for the period of three years and the remaining work will be executed through other agency at the risk and cost of the Contractor.

GC-41 DEFAULT OF CONTRACTOR:

- i) The Corporation may upon written notice of default to the Contractor terminate the contract circumstances detailed as under:
 - a) If in the opinion of the Corporation, the Contractor fails to make completion of works within the time specified in the completion schedule or within the period for which extension has been granted by the Corporation to the Contractor.
 - b) If in the opinion of the Corporation, the Contractor fails to comply with any of the other provisions of this contract.
- ii) In the event, the Corporation terminates the contract in whole or in part as provided in Article GC-50 (Termination of the Contract) the Corporation reserves the right to purchase upon such terms and in such manner as it may be deem appropriate, plant similar to one which is not supplied by the Contractor and the Contractor will be liable to the Corporation for any additional costs for such similar plant and / or for liquidated damages for delay until such time as may be required for the final completion of works.
- iii) If this contract is terminated as provided in this paragraph GC-30 (Power of Entry) the Corporation in addition to any other rights provided in this clause, may require the Contractor to transfer title and deliver to the Corporation.
 - a) Any completed works
 - b) Such partially completed information and contract rights as the Contractor has specifically produced or acquired for the performance of the contract so terminated.
- iv) In the event, the Corporation does not terminate the contract as provided in the paragraph GC-50 (Termination of Contract) the Contractor shall continue performance of the contract, in which case, he shall be liable to the Corporation for liquidated damages for delay until the works are completed and accepted.

GC-42 BANKRUPTCY:

If the Contractor shall become bankrupt or insolvent or has a receiving order made against him, or compound with his creditors, or being the Corporation commence to be wound up not being a

61
member voluntary winding up for the purpose of amalgamation or reconstruction, or carry on its business under a receiver for the benefit of his creditors or any of them, the Corporation shall be at liberty to either (a) terminate the contract forthwith by giving notice in writing to the Contractor or to the receiver or liquidator or to any person or Organization in whom the contract may become vested and to act in the manner provided in Article GC-41 (Default of Contractor) as though the last mentioned notice had been the notice referred to in such article or (b) to give such receiver, liquidator or other persons in whom the contract may become vested the option of carrying out the contract subject to his providing a satisfactory guarantee for the due and faithful performance of the contract up to an amount to be agreed. In the event that the Corporation terminates the contract in accordance with this article, the performance bond shall immediately become due and payable on demand to Corporation.

GC-43 OWNERSHIP:

Works hand over pursuant to the contract shall become the property of the Corporation from whichever is the earlier of the following times, namely;

- a) When the works are completed pursuant to the contract.
- b) When the contractor has been paid any sum to which he may become entitled in respect thereof pursuant to Clause GC-36 (Terms of Payment).

GC-44 DECLARATION AGAINST WAIVER:

The condemnation by the Corporation of any breach or breaches by the Contractor or an authorized sub-contractor of any of the stipulations and conditions contained in the contract, shall in no way prejudice or affect or be construed as a waiver of the Corporation's rights, powers and remedies under the contract in respect of any breach or breaches.

GC-45 LAWS GOVERNING THE CONTRACT:

This contract shall be construed according to and subject to the laws of India and the State of Gujarat and under the jurisdiction of the Courts of Gujarat at Rajkot.

GC-46 OVER PAYMENT AND UNDER PAYMENT:

Whenever any claim for the payment of a sum to the Corporation arises out of or under this contract against the Contractor, the same may be deducted by the Corporation from any sum then due or which at any time thereafter may become due to the Contractor under this contract and failing that under any other contract with the Corporation (which may be available with the Corporation), or from his retention money or he shall pay the claim on demand. The Corporation reserves the right to carry out post payment audit and technical examinations of the final bill including all supporting vouchers, abstracts etc. The Corporation further reserves the right to enforce recovery of any payment when detected, notwithstanding the fact that the amount of the final bill may be included by one of the parties as an item of dispute before an Arbitrator, appointed under Article GC-49 (Arbitration) of this contract and notwithstanding the fact that the amount of the final bill figures in the arbitration award. If as a result of such audit and technical examinations any over payment is discovered in respect of

any work done by the Contractor or alleged to have been done⁶² by him under the contract, it shall be recovered by the Corporation from the Contractor as prescribed above. If any under payment is discovered by the Corporation, the amount due to the Contractor under this contract, may be adjusted against any amount then due or which may at any time thereafter become due before payment is made to the Contractor.

GC-47 SETTLEMENT OF DISPUTES:

Except as otherwise specifically provided in the contract, all disputes concerning questions of fact arising under the contract shall be decided by the Engineer-In-Charge subject to a written appeal by the Contractor to the Engineer-In-Charge and those decisions shall be final and binding on the parties hereto. Any disputes or differences including those considered as such by only one of the parties arising out of or in connection with this contract shall be to the extent possible settled amicably between the parties. If amicable settlement cannot be reached then all disputed issues shall be settled as provided in Article GC-48 (Disputes or differences to be referred to) and Article No.GC-49 (Arbitration).

GC-48 DISPUTES OF DIFFERENCES TO BE REFERRED TO:

If at any time, any question, disputes or differences of any kind whatsoever shall arise between the Engineer-In-Charge and the contractor upon or in relation to or in connection with this contract either party may forthwith give to the other, notice in writing of the existence of such question, dispute or difference as to any decision, opinion, instruction, direction, certificate or evaluation of the Engineer-In-Charge.

GC-49 DELETED:

GC-50 TERMINATION OF THE CONTRACT:

- i) If the Contractor finds it impracticable to continue operation owing to force majeure reasons or for any reasons beyond his control and/or the Corporation find it impossible to continue operation, then prompt notification in writing shall be given by the party affected to the other.
- ii) If the delay or difficulties so caused cannot be expected to cease or become unavoidable or if operations cannot be resumed within two (2) months then either party shall have the right to terminate the contract upon ten (10) days written notice to the other. In the event of such termination of the contract, payment to the Contractor will be made as follows:
 - a) The Contractor shall be paid for all works approved by the Engineer-In-Charge and for any other legitimate expenses due to him.
 - b) If the Corporation terminates the contract owing to Force Majeure or due to any cause beyond its control, the Contractor shall additionally be paid for any work done during the said two (2) months period including any financial commitment made for the proper performance of the contract and which are not reasonably defrayed by payments under (a) above.

- c) The Corporation shall also release all bonds and guarantees at its disposal except in cases where the total amount of payment made to the Contractor exceeds the final amount due to him in which case the Contractor shall refund the excess amount within thirty (30) days after the termination and the Corporation thereafter shall release all bonds and guarantees. Should the Contractor fail to refund the amounts received in excess within the said period such amounts shall be deducted from the bonds or guarantees provided.
- iii) On termination of the contract for any cause the Contractor shall see the orderly suspension and termination of operations, with due consideration to the interests of the Corporation with respect to completion safeguarding of storing materials procured for the performance of the contract and the salvage and resale thereof.

GC-51 SPECIAL RISKS:

If during the contract, there shall be an outbreak of war (whether war is declared or not), major epidemic, earthquake or similar occurrence in any part of the world beyond the control of either party to the contract which financially or otherwise materially affects the execution of the contract, the Contractor shall unless and until, the contract is terminated under the provisions of this article use his best endeavors to complete the execution of the contract, provided always that the Corporation shall be entitled at any time after the onset of such special risks, to terminate the contract by giving written notice to the contractor and upon such notice being given this contract shall terminate but without prejudice to the rights of either party in respect of any antecedent breach thereof.

The Contractor shall not be liable for payment of compensation for delay or for failure to perform the contract for reasons of Force Majeure such as acts of public enemy, acts of Government, fires, floods, cyclones, epidemics, quarantine restrictions, lockouts, strikes, freight embargoes and provided that the Contractor shall within 10 (ten) days from the beginning of such delay notify the Engineer-In-Charge in writing, of the cause of delay, the Corporation shall verify the facts and grant such extension as the facts justify.

GC-52 CHANGE IN CONSTITUTION:

Where the Contractor is a partnership firm, the prior approval in writing of the owner shall be obtained before any change is made in the constitution of the firm. Where the Contractor is an individual or undivided family business concern such approval as aforesaid shall likewise be obtained before the Contractor enters into any partnership agreement where under the partnership firm would have the right to carry out the works hereby undertaken by the Contractor. If prior approval as aforesaid is not obtained, the contract shall be deemed to have been assigned in contravention of contract.

GC-53 SUB-CONTRACTUAL RELATIONS:

All works performed for the contract by a sub-contractor shall be pursuant to an appropriate agreement between the Contractor and

- a) Protect and preserve the rights of the Corporation and the Engineer-In-Charge with respect to the works to be performed under the sub-contracting party will not prejudice such rights.
- b) Require that such work be performed in accordance with the requirements of contract documents.
- c) Require under such contract to which the contractor is a party, the submission to the Contractor of application for payment and claims for additional costs, extension of time, damages for delay or otherwise with respect to the sub-contracted portions of the work in sufficient time, that the Contractor may apply for payment comply in accordance with the contract documents for like claims by the Contractor upon the Corporation.
- d) Waive all rights the contracting parties may have against one another for damages caused by fire or other perils covered by the property insurance except such rights as they may have to the proceeds of such insurance held by the Corporation as trustee and,
- e) Obligate each sub-contractor specifically to consent to the provisions of this Article.

GC-54

PATENTS AND ROYALTIES:

1. Contractor, if licensed under any patent covering equipment, machinery, materials or composition of matter to be used or supplied or methods and process to be practiced or employed in the performance of this contract agrees to pay all royalties and license fees, which may be due with respect thereto. If any equipment, machinery, materials, composition matters, to be used or supplied or methods practiced or employed in the performance of this contract, is covered by a patent under which Contractor is not licensed, then the Contractor before supplying / using the equipment, machinery, materials, compositions, methods of process shall obtain such license and pay such royalties and license fees as may be necessary for performance of this contract. In the event Contractor fails to pay such royalty or to obtain any such license, any suit for infringement of such patents which is brought against the Contractor or the owner as a result of such failure will be defended by the Contractor at his own expenses and the Contractor will pay any damages and costs awarded in such suit. The Contractor shall promptly notify the owner if the Contractor has acquired knowledge of any plant under which a suit for infringement could be reasonably brought because of the use by the owner of any equipment machinery, materials, process methods to be supplied in hereunder. Contractor agrees to and does hereby grant to owner together with the right to extend the same to any of the subsidiaries of the owner an irrevocable royalty fee license to use in any Country, any invention made by the Contractor or his employees in or as a result of the performance of work under contract.

2. With respect to any sub-contract entered into by Contractor pursuant to the provisions of the relevant clause hereof, the Contractor shall obtain from the sub-contractor an understanding to provide the owner with the same patent protection that contracts is required to provide under the provisions of the clause.
3. The Contractor shall indemnify and save harmless the owner from any loss on account of claims against owner for the contributory infringement of patent rights arising out of and based upon the claim that the use by the Corporation of the process included in the design prepared by the Contractor and used in the operation of the plant infringes on any patent rights.

GC-55 LIEN:

If, at any time, there should be evidence of any lien or claim for which owner might have become liable and which is chargeable to the Contractor, the owner shall have the right to retain out of any payment then due or thereafter to become due an amount sufficient to completely indemnify the owner against such lien or claim or if such lien or claim be valid the owner may pay and discharge the same and deduct the amount as paid from any money which may be due or become due and payable to the Contractor. If any lien or claims remaining unsettled after all payments are made, the Contractor shall refund or pay to the owner all money that the latter may be compelled to pay in discharging such lien or claim including all costs and reasonable expenses.

GC-56 EXECUTION OF WORK :

The whole work shall be carried out in strict conformity with the provisions of the contract document, detailed drawings, specifications and the instructions of the Engineer-In-Charge from time to time. The Contractor shall ensure that the whole work is executed in the most substantial, and proper manner with best workmanship using materials of best quality in strict accordance with the specifications to the entire satisfaction of the Engineer-In-Charge.

GC-57 WORK IN MONSOON:

When the work continues in monsoon if required, the Contractor shall maintain minimum labour force required for the work and plan and execute the construction and erection work according to the prescribed schedule. No extra rate will be considered for such work in monsoon. During monsoon and entire construction period, the Contractor shall keep the site free from water at his own cost. However, monsoon period from 1st July to 30th September will be excluded in time limit.

GC-58 WORK ON SUNDAYS AND HOLIDAYS:

No work except curing shall be carried out on Sunday and holidays. However, if the exigencies of the work need continuation of work on Sundays and Holidays, written permission of the Engineer-In-Charge shall be obtained in advance.

GC-59 GENERAL CONDITIONS FOR CONSTRUCTION WORK:

Working hours shall be eight every day. The over time work in two shifts could be carried out with the written permission of the

Engineer-In-Charge but no compensation shall be paid for the same. The rate quoted shall include this. The Contractor shall plan his work in such a way that his labourers do not remain idle. The owner will not be responsible for idle labour of the Contractor. The Contractor shall submit to the owner progress report every week. The details and proforma of the report will be as per mutual agreement.

GC-60 DRAWINGS TO BE SUPPLIED BY THE OWNER:
The drawings attached with the e-Tender documents shall be for general guidance of the Contractor to enable him to visualize the type of work contemplated and scope of work involved. Detail working drawings according to which the work is to be done shall be prepared by the Contractor for executing the work.

GC-61 DRAWINGS TO BE SUPPLIED BY THE CONTRACTOR: (N.A.)
Where drawings, data are to be furnished by the Contractor they shall be as enumerated in special conditions of contract and shall be furnished within the specified time. Where approval of drawings has been specified it shall be Contractor's responsibility to have these drawings got approved before any work is taken up with regard to the same. Any changes becoming necessary in those drawings during the execution of the work shall have to be carried out by the Contractor at no extra cost. All final drawings shall bear the certification stamp as indicated below duly signed by both the Contractor and Engineer-In-Charge.

Certified true for
..... Project Agreement No.....

Signed

Contractor Engineer-In-Charge

Drawings will be approved within three (3 weeks of the receipt of the same by the Engineer-In-Charge.

GC-62 SETTING OUT WORK:
The Contractor shall set out the work on the site handed over by the Engineer-In-Charge and shall be responsible for the correctness of the same. The work shall be carried out to the entire satisfaction of Engineer-In-Charge. The approval thereof or partaking by Engineer-In-Charge or setting out work shall not relieve Contractor of any of his responsibilities. The Contractor shall provide at his own cost all necessary level posts, pegs, bamboos, flags, ranging rods, strings and other materials and labourers required for proper setting out of the work. The Contractor shall provide fix and be responsible for the maintenance of all stakes, templates, level markets, profiles and similar other things and shall take all necessary precautions to prevent their removal or disturbance and shall be responsible for the consequences for such removal or disturbance. The Contractor shall also be responsible for the maintenance of all existing survey marks, boundary marks, and distance marks and centerline marks either existing or face lines and cross lines shall be marked by small masonry pillars. Each pillar shall have distance mark at the center for setting up the theodolite. The work shall not be started unless the setting out is

choked and approved by Engineer-In-Charge in writing but such approval shall not relieve the Contractor of his responsibilities about the correctness of setting out. The Contractor shall provide all materials, labour and other facilities necessary for checking at his own cost. Pillars bearing geodetic marks on site shall be protected by the Contractor. On completion of the work, the Contractor shall submit the geodetic documents according to which the work has been carried out.

GC-63 RESPONSIBILITIES OF CONTRACTOR FOR CORRECTNESS OF THE WORK :

The Contractor shall be entirely and exclusively responsible for the correctness of every part of the work and shall rectify completely any errors therein at his own cost when so instructed by Engineer-In-Charge. If any error has crept in the work due to non-observance of this clause, the Contractor will be responsible for the error and bear the cost of corrective work.

1. Materials to be supplied by the Contractor:
Contractor shall procure and provide all the material required for the execution and maintenance of work including M S rods; all tools, tackles, construction plant and equipment except, the materials to be supplied by the owner detailed in the contract documents. Owner, shall make recommendations for procurement of materials to the respective authorities if desired by the Contractor but assumes no responsibility of any nature. Owner shall insist for procurement of materials with ISI marks supplied by reputed firms of the DGS & D list.
2. If however, the Engineer-In-Charge feels that the work is likely to be delayed due to Contractor's inability to procure materials, the Engineer-In-Charge shall have the right to procure materials, from the market and the Contractor will accept these materials at the rates decided by Engineer-In-Charge.

GC-64 MATERIALS TO BE SUPPLIED BY THE OWNER:

1. If the contract provided certain materials or stores to be supplied by the owner, such materials and stores transported by the Contractor at his cost from owner's stores or Railway Station. The cost from Contractor for the value of materials supplied by the owner will be recovered from the R.A.Bill on the basis of actual consumption of materials in the work covered and for which R A Bill has been prepared. After completion of the work, the Contractor has to account for the full quantity of materials supplied to him.
2. The value of store materials supplied by owner to the Contractor shall be charged at rates shown in the contract document and in case any other material not listed in the schedule of materials is supplied by the owner, the same shall be charged at cost price including carting and other expenses incurred in procuring the same. All materials so supplied shall remain the property of the owner and shall not be removed from the site on any account. Any material remaining unused at the time of completion of work or termination of contracts shall be returned to owner's store or any other place as directed by the Engineer-In-Charge in perfectly good condition at Contractor's cost. When materials are supplied free of cost for use in work and surplus and unaccounted balance thereof

are not returned to the owner, recovery in respect of such balance will be effected at double the applicable issue rate of the material or the market rates whichever is higher.

GC-65 CONDITIONS OF ISSUE OF MATERIALS BY THE OWNER:
(N.A.)

The materials specified to be issued by the owner to the Contractor shall be issued by the owner at his store and all expenses for it carting site shall be borne by the Contractor will be issued during working hours and as per rules of owner from time to time.

Contractor shall bear all expenses for storage and safe custody at site of materials issued to him before use in work.

Material shall be issued by the owner in standard / non-standard sizes as obtained from manufacturer.

Contractor shall construct suitable godowns at site for storing the materials to protect the same from damage due to rain, dampness, fire, theft etc.

The Contractor should take the delivery of the materials issued by the owner after satisfying himself that they are in good condition. Once the materials are issued, it will be the responsibility of the Contractor to keep them in good condition and in safe custody. If the materials get damaged or if they are stolen, it shall be the responsibility of the Contractor to replace them at his cost according to the instructions of the Engineer-In-Charge.

For delay in supply or for non-supply of materials to be supplied by the owner, on account of natural calamities, act of enemies, other difficulties beyond the control of the owner, the owner carries no responsibilities. In no case the Contractor shall be entitled to claim any compensation for loss suffered by him on this account.

None of the materials issued to the contractor, shall be used by the Contractor for manufacturing items which can be obtained from the manufacturer's. The materials issued by the owner shall be used for the work only and no other purpose.

Contractor shall be required to execute indemnity bond in the prescribed form for the safe custody and account of materials issued by the owner.

Contractor shall furnish sufficiently in advance a statement of his requirements of quantities of materials to be supplied by the owner and the time when the same will be required for the work, so as to enable Engineer-In-Charge to make arrangements to procure and supply the materials.

A daily account of materials issued by the owner shall be maintained by the contractor showing receipt, consumption and balance on hand in the form laid down by Engineer-In-Charge with all connected paper and shall be always available for inspection in the site office.

Contractor shall see that only the required quantities of materials are got issued and no more. The Contractor shall be responsible to return the surplus materials at owner's store at his own cost.

- GC-66 **MATERIALS PROCURED WITH ASSISTANCE OF THE OWNER**
: Notwithstanding anything contained to the contrary in any of the clauses of this contract, where any materials for the execution of the contract are procured with the assistance of the owner either by issue from owner's stock or purchase made under orders or permits or licenses issued materials as trustees for owner, and use such materials not disposed them off without the permission of owner and unserviceable materials that may be left with him after completion of the contract or at its termination for any reason whatsoever on his being paid or credited such price as Engineer-In- Charge shall determine having due regard to the conditions of the materials. The price allowed to Contractor shall not exceed the amount charged to him excluding the storage of breach of the aforesaid condition, the Contractor shall in terms of license or permits and/or for criminal breach of trust be liable to compensate owner at double the rate or any higher rates. In the event of these materials at that time having higher rate or not being available in the market then any other rate to be determined by the Engineer- In-Charge at his decision shall be final and conclusive.
- GC-67 **MATERIALS OBTAINED FROM DISMANTLING:**
If the Contractor, in the course of execution of work, is called upon to dismantle any part of work for reasons other than on account of bad or imperfect work, the materials obtained from dismantling will be property of the owner and will be disposed off as per instructions of Engineer-In-Charge in the best interest of the owner.
- GC-68 **ARTICLE OF VALUE OF TREASURE FOUND DURING CONS- TRUCTION:**
All gold, silver and other minerals of any description and all precious stones, coins, treasures, relics, antiques and other similar things which shall be found in, under or upon site shall be the property of the owner and the Contractor shall properly preserve the same to the satisfaction of the Engineer-In-Charge and shall hand over the same to the owner.
- GC-69 **DISCREPANCIES BETWEEN INSTRUCTIONS:**
If there is any discrepancy between various stipulations of the contract documents or instructions to the Contractor or his authorized representative or if any doubt arises as to the meaning of such stipulation or instructions, the Contractor shall immediately refer in writing to the Engineer-In-Charge and shall hand over the same to the owner.

The Architect / Engineer-In-Charge shall have power to make any alterations in, omission from, addition to substitution for, the schedule of rates, the original specifications, drawings, designs and instructions that may appear to him to be necessary or advisable during the progress of work and the Contractor shall be bound to carry out such altered / extra / new items of work in accordance with any instructions which may be given to him in writing signed by Engineer-In-Charge and such alteration omissions, additions or substitutions, shall not invalidate contract and any altered, additional or substituted work shall be carried out by the Contractor on the same conditions of contract. The time of completion may be extended by Architect as may be considered just and reasonable by him. The rates for such additional altered or substitute work shall be worked out as under:

- a) If the rates for additional, altered or substitutes work are specified in the contract for work, the Contractor is bound to carry out such work at the same rates as specified in the contract.
- b) If the rates for additional, altered or substituted work are not specifically provided in the contract for the work, the rates will be derived from the rates of similar items of work in the contract work. The opinion of Engineer-In-Charge as to whether the rates can be reasonably so derived the items of contract will be final and binding to the Contractors.
- c) If the rates of altered, additional or substitute work cannot be determined as specified in (a) or (b) above, the rate shall be paid as per S.O.R. of RMC and if not available in RMC SOR then it will be paid according to SOR of R&B/GWSSB.
- d) If the rates of altered, additional or substitute work cannot be determined as specified in (a) or (b) or (c) above, the Contractor shall within seven days of the receipt of order to carry out the work inform the Architect / Engineer-In-Charge of the rate which he intends to charge for such work supported by rate analysis and the Architect / Engineer-In- Charge will determine the rate on the basis of prevailing market rates of materials, labour cost at schedule of labour plus 15% there on as Contractor's supervision overheads and profit. The opinion of Architect / Engineer-In-Charge as to the market rates of materials and the quantity of labour involved per unit of measurement will be final and binding on Contractor.

But under no circumstances, the Contractor suspends work or the plea of non settlement of items falling under this clause.

In case of any class of work for which no specifications is supplied by the owner in the e-Tender documents, such work shall be carried out in accordance with relevant latest ISS and if ISS do not cover the same, the work shall be carried out as per General Technical Specification for building work; and if not covered in then it is to be with standard Engineering Practice subject to the approval of Engineer-In-Charge.

GC-72 ABNORMAL RATES:

Contractor is expected to quote rate for each item after careful analysis of cost involved for the performance of the completed item considering all specifications and conditions of contract.

GC-73 ASSISTANCE TO ENGINEER-IN-CHARGE:

Contractor shall make available to Engineer-In-Charge free of cost all necessary instruments and assistance in checking of any work made by the Contractor setting out for taking measurement of work etc.

GC-74 TESTS FOR QUALITY OF WORK :

1. The Contractor shall be required to give satisfactory flow test where required and shall rectify the defects, if any, free of cost. The necessary water, power, labour etc., required for the flow test shall also be arranged by the Contractor at his own cost.
2. All workmanship shall be of the best kind described in the contract documents and in accordance with the instructions of Engineer-In-Charge and shall be subjected from time to time to such tests at Contractor's cost as the Engineer-In-Charge may direct at the place of manufacture of fabrication or on the site or at any such place. Contractor shall provide assistance, instruments, labour and materials as are normally required for examining, measuring and testing of any work of workmanship as may be selected and required by Engineer-In-Charge.
3. All tests necessary in connection with the execution of work as decided by Engineer-In-Charge shall be carried out at an approved laboratory at Contractor's cost.
4. Contractor shall furnish the Engineer-In-Charge for approval when requested or if required by the specification, adequate samples of all materials and finished goods to be used in work sufficiently in advance to permit tests and examination thereof. All materials furnished and finished goods applied in work shall be exactly as per the approved samples.

GC-75 ACTION AND COMPENSATION IN CASE OF 72
BAD WORKMANSHIP:

If it shall appear to the Engineer-In-Charge that any work has been executed with materials of inferior description, or quality or are unsound or with unsound, imperfect or unskilled workmanship or otherwise not in accordance with the contract, the Contractor shall, on demand in writing from Engineer-In-Charge or his authorized representative specifying the work, materials or articles complained of, notwithstanding that the same may have been inadvertently passed, certified and paid for, forthwith rectify or remove and reconstruct the work, so specified. In the event of failure to do so within a period to be specified by the Engineer-In-Charge in his aforesaid demand, Contractor shall be liable to pay compensation at the rate of 0.1(zero point one) percent of the value of work for per day of delay on Amount forming delayed work i.e. uncompleted work amount and this shall be limited to a maximum of ten (10%) percent of the value of work while his failure to do so continues and in the case of any such failure, the Engineer-In-Charge may on expiry of the notice period rectify and remove and re-execute the work or remove and replace with others at the risk and cost of the Contractor. This amount shall be limited to maximum of 25% of uncompleted work amount. The decision of the Engineer-In-Charge as to any question arising under this clause shall be final and conclusive. These both type of compensation shall be applied individually.

GC-76 SUSPENSION WORK:

Contractor shall, if ordered in writing by Engineer-In-Charge or his representative temporarily suspended the work or any part thereof for such time (not exceeding one month) as ordered and shall not after receiving such written notice proceed with the work until he shall have received a written order to proceed therewith. The Contractor shall not be entitled to claim compensation for any loss or damage sustained by him by reason of temporary suspension of work as aforesaid. An extension of time for completion of work will be granted to the Contractor corresponding to the delay caused by such suspension of work if he applies for the same provided the suspension was not consequent upon any default or failure on the part of the Contractor.

GC-77 OWNER MAY DO PART OF THE WORK:

When the Contractor fails to comply with any instructions given in accordance with the provisions of this contract, the owner has the right to carry out such parts of work as the owner may designate whether by purchasing materials and engaging labour or by the agency of another Contractor. In such case the owner shall deduct from the amount which otherwise might become due to Contractor, the cost of such work and materials with then (10) percent added to cover all departmental charges and should the total amount thereof exceed the amount due to contract, Contractor shall pay the difference to owner.

GC-78 POSSESSION PRIOR TO COMPLETION:

The Engineer-In-Charge shall have the right to take possession of or to use any completed or partly completed work or part of work. Such possession or use shall not be deemed to be an acceptance of any work completed in accordance with the contract. If such prior possession or use by Engineer-In-Charge delays the process of work, equitable adjustment in the time of completion will be made and the contract shall be deemed to be modified accordingly.

GC-79 COMPLETION CERTIFICATE:

As soon as the work has been completed in accordance with contract (except in minor respects that do not effect their use for the purpose for which they are intended and except for maintenance thereof) as per General Conditions of Contract the Engineer-In-Charge shall issue a certificate (hereinafter called completion certificate) in which shall certify the date on which work has been completed and has passed the said tests and owner shall be deemed to have taken over work on the date so certified. If work has been divided in various groups in contract, owner shall be entitled to take over any group or groups before the other or others and there upon the Engineer-In-Charge will issue a completion certificate, which will, however, be for such group or groups so taken over.

In order that Contractor could get a completion certificate, he shall make good will all speed any defect arising from the defective materials supplied by Contractor of workmanship or any act or omission of Contractor that may have been discovered or developed after the work or groups of works has been taken over. The period allowed for carrying out such work will be normally, one month. If any defect be not remedied within the time specified, owner may proceed to do work at Contractor's (Agency, or Firm) risk and expenses and deduct from the final bill such amount as may be decided by owner. If by reason of any default on the part of the Contractor, a completion certificate has not been issued in respect of every portion of work within one month after the date fixed by contract for completion of work, owner shall be at liberty to use work or any portion thereof in respect of which a completion certificate has been issued, provided that work or the portion thereof so used as aforesaid shall be afforded reasonable opportunity for completion of that work or the portion thereof so used as aforesaid shall be afforded reasonable opportunity for completion of that work for the issue of completion certificate.

GC-80 SCHEDULE OF RATES:

1. The rates quoted by the Contractor shall remain firm till the completion of the work and shall not be subject to escalation. Schedule of rates shall be deemed to include and cover all costs, expenses and liabilities of every description and risks or every kind to be taken in executing, completing and handing over the work to owner by Contractor. The contractor shall be deemed to have known the nature, scope, magnitude and the extent of work and materials required though contract documents may not fully and

precisely furnish them. He shall make such provision in ⁷⁴the Schedule of Rates as he may consider necessary to cover the cost of such items of work and materials as may be reasonable and necessary to complete the work. The opinion of Engineer-In-Charge as to the item of work which are necessary and reasonable for completion of the work shall be final and binding on Contractor although the same may be not shown on drawings or described specifically in contract documents.

2. The Schedule of Rates shall be deemed to include and cover the cost of all constructional plant, temporary work, materials, labour and all other matters in connection with each item in Schedule of Rates and the execution of work or any portion thereof finished complete in every respect and maintained as shown or described in the contract document or as may be ordered in writing during the continuance of the contract.
3. The Schedule of Rates shall be deemed to include and cover the cost of all royalties and fees for the articles and processes, protected by letters patent or otherwise incorporated in or used in connection with work, also all royalties, rents and other payments in connection with obtaining material of whatsoever kind for work and shall include an indemnity to owner which Contractor hereby gives against all action, proceedings, claims, damages, costs and expenses arising from the incorporation in or use on the works of any such articles, processes or materials. Other Municipal or local Board charges if levied on material, equipment or machineries to be brought to site for use on work shall be borne by the Contractor.
4. No exemption or reduction of custom duties, excise duties, sales tax or any other taxes or charges of the Central or State Government or of any Local Body whatsoever will be granted or obtained and all such expenses shall be deemed to have been included in and covered by Schedule of Rates. Contractor shall also obtain and pay for all permits or other privileges necessary to complete the work.
5. The Schedule of Rates shall be deemed to include and cover risk on account of delay and interference with Contractor's conduct of work which may occur from any cause including orders of owner in the exercise of his powers and on account of extension of time granted due to various reasons.
6. For work under unit rate basis, no alteration will be allowed in the Schedule of Rates by reasons of work or any part of them being modified, altered, extended, diminished or omitted.

GC-81

PROCEDURE FOR MEASUREMENT OF WORK IN PROGRESS:

1. All measurements shall be in metric system. All the work in progress will be jointly measured by the representative of Engineer-In-Charge and Contractor's authorized agent. Such measurements will be got recorded in the Measurement Book by the Engineer-In-Charge or his authorized representative and signed by the Contractor or his authorized agent in token of acceptance. If the Contractor or his authorized agent fails to be present

whenever required by the Engineer-In-Charge for taking⁷⁵ measures for every reasons whatsoever, the measurement will be taken by the Engineer-In-Charge or his authorized representative notwithstanding the absence of Contractor and these measurements will be deemed to be correct and binding on the Contractor.

2. Contractor will submit a bill in approved proforma in quadruplicate to the Engineer-In-Charge of the work giving abstract and detailed measurements of various items executed during a month as mutually agreed. The Engineer-In-Charge shall verify the bill and the claim, as far as admissible, adjusted if possible, within 10 days of presentation of the bills.

GC-82 RUNNING ACCOUNT PAYMENTS TO BE REGARDED AS ADVANCES :

1. All running account payments shall be regarded as payments by way of advance against the final payment only and not as payment for work actually done and completed and shall not preclude the requiring of bad, unsound and imperfect or unskilled work to be removed and taken away and reconstructed or rejected or to be considered as an admission of the due performance of contract or any part thereof.
2. Five (5) percent of the gross R A Bill amount shall be retained from each bill as retention amount and the same will be paid with the final bill.

GC-83 NOTICE FOR CLAIM FOR ADDITIONAL PAYMENT:

If the Contractor considers that he is entitled to extra payment or compensation or any claim whatsoever in respect of work, he shall forthwith give notice in writing to the Engineer-In-Charge about his extra payment and / or compensation. Such notice shall be given to the Engineer-In-Charge within ten (10) days from the happening of any event upon which Contractor basis such claims and such notice shall contain full particulars of the nature of such claim with full details and amount claimed. Failure on the part of the Contractor to put forward any claim with the necessary particulars as above, within the time above specified shall be an absolute waiver thereof. No omission by owner to reject any such claim and no delay in dealing therewith shall waiver by owner or any rights in respect thereof.

GC-84 PAYMENT OF CONTRACTOR'S BILL:

1. The price to be paid by the owner to Contractor for the work to be done and for the performance of all the obligations undertaken by the Contractor under contract shall be based on the contract price and payment to be made accordingly for the work actually executed and approved by the Engineer-In- Charge.
2. No payment shall be made for work costing less than Rs.5,00,000/- till the work is completed and a certificate of completion given. But in case of work estimated to cost more than Rs.5,00,000/-. Contractor on submitting the bill thereof will be entitled to receive a monthly payment proportionate to the part thereof, approved

and passed by Engineer-In-Charge, whose certificate of such approval and passing of the sum so payable shall be final and conclusive against contractor. This payment shall be made after necessary deductions as stipulated elsewhere in the contract documents for materials, security deposit etc. The payment shall be released to the Contractor within Two (2) month of submission of the bill duly pre- occupied on proper revenue stamp. Payment due to Contractor shall be made by the owner by Electronic clearing system or RTGS only in Indian currency. Successful bidder must furnish his details for the ECS/RTGS.

GC-85 FINAL BILL:
The final bill shall be submitted by Contractor within one (1) month of the date of physical completion of work, otherwise the Engineer- In-Charge's certificate of the measurement and of total amount payable for work shall be final and binding on all parties.

GC-86 RECEIPTS FOR PAYMENT:
Receipt for payment made on account of work when executed by a firm must be signed by a person holding Power of Attorney in this respect on behalf of Contractor except when described in the e- Tender as a limited company in which case the receipt must be signed in the name of the Company by one of its principal officers or by some person having authority to give effectual receipt for the Company.

GC-87 COMPLETION & Performance CERTIFICATE:
1. When the Contractor fulfils his obligation as per terms of contract, he shall be eligible to apply for Completion Certificate. Contractor may apply for separate Completion Certificate in respect of each such portion of work by submitting the completion documents along with such application for Completion Certificate.

The Engineer-In-Charge shall normally issue to Contractor the Completion Certificate within one (1) month after receiving an application thereof from Contractor after verifying, from the completion documents and satisfying himself that work has

been completed in accordance with and as set out in the construction and erection drawings and the contract documents. Contractor after obtaining the Completion Certificate is eligible to present the final bill for work executed by him under the terms of contract.

2. Within one month of completion of work in all respects Contractor shall be furnished with a certificate by the Engineer-In-Charge of such completion but no certificate shall be given nor shall work be deemed to have been executed until all (i) scaffolding, surplus materials and rubbish is cleaned off site completely, (ii) until work shall have been measured by the Engineer-In-Charge whose measurement shall be binding and conclusive and, (iii) until all the temporary works, labour and staff colonies etc. constructed are removed and the work site cleaned to the satisfaction of the Engineer-In-Charge. If Contractor shall fail to comply with the requirements as

aforsaid or before date fixed for the completion of work, ~~77~~ the Engineer-In-Charge may at the expense of Contractor remove such scaffolding, surplus materials and rubbish and dispose off the same as he thinks fit.

3. The following documents will form the completion documents: -

Technical documents according to which the work has been carried out.

- a) Three sets of construction drawings showing therein the modifications and corrections made during the course of execution signed by the Engineer-In-Charge.
 - b) Completion Certificate for "Embedded" or "Covered" up work.
 - c) Certificate of final levels as set out for various works.
 - d) Certificate of test performed for various work.
 - e) Material appropriation statement for the materials issued by owner for work and list of surplus materials returned to owner's store duly supported by necessary documents.
4. Upon expiry of the period of defect liability and subject to Engineer-In-Charge being satisfied that work has been duly maintained by Contractor during the defect liability period of fixed originally or as extended subsequently and that Contractor has in all respects made up any subsidence and performed all his obligations under contract, the Engineer-In-Charge (without prejudice to the rights of owner in any way) give final certificate to that effect. The Contractor shall not be considered to have fulfilled the whole of his obligation until final certificate shall have been given by the Engineer-In-Charge.
5. Final Certificate only evidence of completion:
Except the final certificate, no other certificate of payment against a certificate or on general account shall be taken to be an admission by owner of the due performance of contract or any part thereof of occupancy or validity or any claim by the Contractor.

GC-88

TAXES, DUTIES, ETC. :

1. Contractor agrees to and does hereby accept full and exclusive liability for the payment of any and all taxes including Sales Tax, Duties, etc., now or hereinafter imposed, increased or modified from time to time in respect of work and materials and all contributions and taxes for unemployment, compensation, insurance and old age pension or annuities now or hereinafter imposed by the Central or State Government authorities with respect to or covered by the wages, salaries or other compensation paid to the persons employed by Contractor.

If the Contractor is not liable to Sales Tax assessment, a certificate to that effect from the Competent Authority shall be produced without which final payment to the Contractor shall not be made. P, 'C' and 'D' Form shall not be supplied

by the owner, and the Contractor shall be required to pay ⁷⁸ full tax as applicable.

2. Contractor shall be responsible for compliance with all obligations and restrictions imposed by the labour law or any other law affecting employer-employee relationship.
3. Contractor further agrees to comply and to secure the compliance of all sub contractors with applicable Central, State, Municipal and local laws and regulations and requirement. Contractor also agrees to defend, indemnify the hold harmless the owner from any liability or penalty which may be imposed by Central, State or local authority by reasons of any violation by Contractor or sub Contractor of such laws, regulations or requirements and also from all claims, suits or proceedings that may be brought against owner arising under, growing out of or by reasons or work provided for by this Contract by third parties or by Central or State Government authority or any administrative Sub-Division thereof.
4. The Sales Tax on work contract will be borne by Contractor.

GC-89

INSURANCE:

Contractor shall at his own expenses carry and maintain the reputable Insurance Companies to the satisfaction of owner as follows:

1. Contractor agrees to and uses hereby accept full and exclusive liability for compliance with all obligations imposed by the Employer's State Insurance Act, 1948 and Contractor further agrees to defend, indemnify and hold owner harmless from any liability or penalty which may be imposed by the Central or State Government or local authority by reasons of any assorted violation by Contractor or Sub-Contractor or the Employees State Insurance Act, 1948 and also from all claims, suits or proceedings that may be brought against owner arising under, growing out of or by reasons of the work provided for by this contract whether brought by employees of Contractor by third parties or by Central or State Government authority or any administrative Sub-division thereof. Contractor agrees to fill in with the Employees State Insurance Corporation, the declaration form and all forms which may be required in respect of Contractor's or sub-Contractor's employees whose aggregate remuneration is Rs.400/- p.m. or less and who are employed in work provided for or those covered by ESI from time to time under the agreement. The Contractor shall deduct and secure the agreement of the sub- Contractor to deduct the employee's contribution as per the first schedule of the Employees State Insurance Act from wages. Contractor shall remit and secure the agreement of sub- contractor to remit to the State Bank of Indian Employees State Insurance Accounts, the employee's contribution as required by the Act. Contractor agrees to maintain all cards and records as required under the Act in respect of employees and payments and Contractor shall secure the agreements of the sub contractors to maintain in such records, any expenses incurred for the contributions, making contributions or maintaining records shall be to Contractors or sub-contractors

own account. owner shall retain such sum as may ⁷⁹ be necessary from the contract value until Contractor shall furnish satisfactory proof that all contribution as required by the Employees State Insurance Act, 1948 have been paid.

2. Workman's compensation and employees liability insurance:

Insurance shall be effected for all Contractors employees engaged in the performance of this contract. If any part of work is sublet, Contractor shall require the sub-Contractor to provide workman's compensation and employer's liability insurance, which may be required by owner.

3. Other Insurance required under law of regulations or by owner Contractor shall also carry and maintain any and all other insurance which may be required under any law or regulation from time to time. He shall also carry and maintain any other insurance, which may be required by owner.

GC-90 DAMAGE TO PROPERTY :

1. Contractor shall be responsible for making good to the satisfaction of owner any loss of and any damage to all structures and properties belonging to owner or being executed or procured or being procured by owner or of other agencies within the premises of all work of owner, if such loss or damage is due to fault and / or the negligence of willful act or omission of Contractor, his employees, agent, representatives or sub- Contractor s.
2. Contractor shall indemnify and keep owner harmless of all claims for damage to properties other than property arising under by reasons of this agreement; such claims result from the fault and / or negligence or willful act or omission of Contractor, his employees, agents representative or sub-contractor.

GC-91 CONTRACTOR TO INDEMNIFY OWNER:

1. The Contractor shall indemnify and keep indemnified the owner and every member, officer and employee of owner from and against all actions, claims, demands and liabilities whatsoever under the in respect of the breach of any of the above clauses and / or against any claim, action or demand by any workman / employee of the Contractor or any sub-contractor under any laws, rules or regulations having force of laws, including but not limited to claims against the owner under the workman compensation Act, 1923, the Employee's Provident Funds Act, 1952 and / or the contract labour (Abolition and Regulations) Act, 1970.
2. PAYMENTS OF CLAIMS AND DAMAGES : If owner has to pay any money in respect of such claims or demands aforesaid, the amount so paid and the cost incurred by the owner shall be charged to and paid by Contractor without any dispute not withstanding the same may have been paid without the consent or authority of the Contractor.
3. In every case in which by virtue of any provision applicable

in the workman's Compensation Act, 1923 or any other Act, owner be obliged to pay compensation to workmen employed by Contractor the amount of compensation so paid, and without prejudice to the rights of owner under Section-(12) Sub- section-(2) of the said Act, owner shall be at liberty to recover such amount from any surplus due to or to become due to the Contractor or from the security deposit. Owner will not be bound to contest any claim made under Section-(12) Sub- section-(2) of the said act except on written request of Contractor and giving full security for all costs consequent upon the contesting of such claim.

The Contractor shall protect adjoining sites against structural, decorative and other damages that could be caused to adjoining premises by the execution of these works and make good at his cost, any such damage, so caused.

GC-92 IMPLEMENTATION OF APPRENTICE ACT Prevailing Latest Revision:

Contractor shall comply with the provisions of the apprentice Act Prevailing Latest Revision and the orders issued there under from time to time. If he fails to do so, it will be a breach of contract.

GC-93 HEALTH AND SANITARY ARRANGEMENTS FOR WORKERS:

Contractor shall comply with all the rules and regulations of the local Sanitary Authorities or as framed by owner from time to time for the protection of health and provide sanitary arrangements of all labour directly or indirectly employed on the work of this contract.

GC-94 SAFETY CODE: General:

Contractor shall adhere to safe construction practice and guard against hazardous and unsafe working conditions and shall comply with owner's rules as set forth herein.

1.0 First Aid and Industrial Injuries:

1.1 Contractor shall maintain First-Aid facilities for its employees and those of his sub-contractors.

1.2 Contractor shall make outside arrangements for ambulance service and for the treatment of industrial injuries. Name of those providing these services shall be furnished to Engineer- In-Charge prior to start of construction, and their telephone numbers shall be prominently posted in Contractor's field office.

1.3 All injuries shall be reported promptly to Engineer-In-Charge and a copy of Contractor's report covering each personal injury requiring the attention of a physician shall be furnished to owner.

2.0 General Rules:

2.1 Carrying and striking, a match lighters inside the project area and smoking within the job site is strictly prohibited.

Violators of smoking rules shall be discharged immediately. Within the operation area, no hot work shall be permitted, without valid gas, safety, fire permits. The Contractor shall also be held liable and responsible for all lapses of his sub-Contractors / employees in this regard.

3.0 Contractor's Barricades:

3.1 Contractor shall erect and maintain barricades without any extra cost, required in connection with his operation to guard or

protect during the entire phase of the operation of this contract for -

- I. Excavation
- II. Hoisting areas
- III. Areas adjudged hazardous by Contractor's OR Owner's inspectors.
- IV. Owner's existing property liable to be damaged by Contractor's operations, in the opinion of Engineer-In-Charge / Site Engineer.

3.2 Contractor's employees and those of his sub-contractors shall become acquainted with owner's barricading practices and shall respect the provisions thereof.

3.3 Barricades and hazardous areas adjacent to but not located in normal routes of travel shall be marked by red lantern at night.

4.0 Scaffolding:

4.1 Suitable scaffolding shall be provided for workman for all works that cannot safely be done from ladders. When a ladder is used, an extra mazdoor shall be engaged for holding the ladder and if the ladder is used for carrying materials as well suitable footholds and handholds shall be provided on the ladder and the same shall be given an inclination not steeper than 1 in 4 (1 horizontal and 4 vertical).

4.2 Scaffolding or staging, more than 3.6 M. (12') above the ground or floor, swing or suspended from an overhead support or erected with stationary support shall have a guard rail properly attached, bolted, braced and otherwise fixed at least 1.0 M (3') high above the floor or platform or scaffolding or staging and extending along the entire length of the outside ends thereof with only such openings as may be necessary for the delivery of materials. Such scaffolding or staging shall be so fastened as to prevent it from swaying from the building or structure.

4.3 Working platforms, gangways, and stairways should be so constructed that they should not sag unduly or inadequately and if the height of the platform or the gangway of the stairway is more than 3.6 (12') above ground level or floor level, they should be closely boarded, should have adequate width and should be suitably fastened as described in 4.2 above.

4.4 Every opening in the floor of a building or in a working platform be provided with suitable means to prevent the fall of persons or materials by providing suitable fencing or railing whose minimum height shall be 1.0 M (3'.0").

- 4.5 Safe means of access shall be provided to all working platforms and other working places. Every ladder shall be securely fixed. No portable single ladder shall be over 9.0 M. (30') in length while the width between the side rails in rung ladder shall in no case be less than 30 cms (12 inches) for ladder up to and including 3.0 M. (10'), in longer ladders this width would be increased at least 6 mm (1/4") for each addition 30 c.m. (1.0) of length. Uniform step spacing shall not exceed 30 cms. (12"). Adequate precaution shall be taken to prevent danger from electrical equipment. No materials on any of the side of work shall be so stacked or placed as to cause danger or inconvenience to any person or public. The Contractor shall also provide all necessary fencing and lights to protect the workers and staff from accidents, and shall be bound to bear the expenses of defense of every suit action or other proceedings at law that may be brought by any persons for injury sustained owing to neglect of the above precautions and to pay damages and costs which may be awarded in any such suit or action or proceedings to any such person, or which, may be with the consent of the Contractor be paid to compromise any claim by any such person.
- 5.0 Excavation:
- 5.1 All trenches 1.2 M (4') or more in depth shall at all time be supplied with at least one ladder.
- 5.2 Ladder shall be extended bottom of the trench to at least 3" above the surface of the ground. The side of the trench which are 1.5 M (5') or more in depth shall be stopped back to give suitable slope, or securely held by timber bracing, so as to avoid the danger of sides to collapse. The excavated materials shall not be placed within 1.5 M (5') of the trench of half of the trench depth whichever is more. Cutting shall be done from top to bottom. Under no circumstances, undermining or under cutting be done.
- 6.0 Demolition:
- 6.1 Before any demolition work is commenced and also during the progress of the work all roads and open area adjacent to the work site shall either be closed or suitably protected.
- 6.2 No electric cable or apparatus which is liable to be a source of danger shall remain electricity charged.
- 6.3 All practical steps shall be taken to prevent danger to persons employed from risk of fire or explosion of flooding. No floor or other part of the building shall be so over loaded with debris or materials as to render it unsafe.
- 7.0 Safety Equipment:
- 7.1 All necessary personal safety equipment as considered necessary by the Engineer-In-Charge should be made

available for the use of persons employed on the site and maintained in a condition suitable for immediate use, and the Contractor should take adequate steps to ensure proper use of equipment by those concerned.

- 7.2 Workers employed on mixing asphaltic materials, cement and lime mortars shall be provided with protective footwear and protective gloves.

8.0 Risky Place:

- 8.1 When the work is done near any place where there is a risk of drowning, all necessary safety equipment shall be provided and kept ready for use and all necessary steps taken for prompt rescue of any person in danger and adequate provision should be made for prompt first-aid treatment of all injuries likely to be sustained during the course of the work.

9.0 Hoisting Equipment:

- 9.1 Use of hoisting machines and tackles including their attachments, and storage and supports shall conform to the following standards or conditions.
- 9.2 These shall be of good mechanical construction, sound material and adequate strength and free from patent defect and shall be kept in good condition and in good working order.
- 9.3 Every rope used in hoisting or lowering materials or as a means of suspension shall be of durable quality and adequate strength and free from patent defects.
- 9.4 Every crane driver or hoisting appliance operator shall be properly qualified and no person under the age of 21 years should be in-charge of any hoisting machine including any scaffolding.
- 9.5 In case of every hoisting machine and of every chain ring hook, shackle, swivel and pulley block used in hoisting or lowering or as means of suspension, the safe working load shall be ascertained by adequate means. Every hoisting machine and all gear referred to above shall be plainly marked with the safe working load and the conditions under which it is applicable shall be clearly indicated. No part of any machine or any gear referred to above in this paragraph shall be loaded beyond the safe working load except for the purpose of testing.
- 9.6 In case of departmental machine, the safe work load shall be notified by the Engineer-In-Charge, as regards Contractor's machine, the Contractor shall, notify, the safety working load of the machine to the Engineer-In-Charge. Whenever the

Contractor brings any machinery to site of work he should get it verified by the Engineer-In-Charge concerned.

10.0 Electrical Equipment:

Motors, gears, transmission, electric wiring and other dangerous parts of hoisting appliances shall be provided with efficient safeguards, hoisting appliances should be provided with such means when will reduce to the minimum the risk of accidental descent of the load, adequate precautions shall be taken to reduce to the minimum the risk of any part or a suspended load becoming accidentally displaced. When workers are employed on electrical installations which are already energized, insulating mats, wearing apparel such as gloves, and booths as may be necessary shall be provided. The workers shall not wear any rings, watches and carry keys or other materials which are good conductors of electricity.

11.0 Maintenance of Safety Devices:

All scaffolds, ladders and other safety devices as mentioned or described herein shall be maintained in sound condition and no scaffold, ladder or equipment shall be altered or removed while it is in use. Adequate washing facilities should be provided at or near place of work.

12.0 Display of Safety Instructions:

The safety provisions should be brought to the notice of all concerned by display on a Notice Board at a prominent place at the work spot. The persons responsible for compliance of the safety code shall be named therein by the Contractor.

13.0 Enforcement of Safety Regulations:

To ensure effective enforcement of the rules and regulations relating to safety precautions, the arrangement made by the Contractor shall be open to inspection by the Welfare Officer, Engineer-In-Charge or Safety Engineer of the owner or their representatives.

14.0 No Exemption:

- 14.1 Notwithstanding the above clause 1.0 to 13.0 there is nothing to exempt the Contractor from the operations of any other Act or Rules in force in the Republic of India.

- 14.2 In addition to the above, the Contractor shall abide by the safety code provisions as per C.P.W.D. safety code framed from time to time.

GC-95 ACCIDENTS:

It shall be Contractor's responsibility to protect against accidents on the works. He shall indemnify the owner against any claim for damage or for injury to person or property resulting from, and in the course of work and also under the provisions of the workman's compensation Act. On the occurrence of an accident arising out of the works which results in death or which is so serious as to be likely to result in death, the Contractor shall within twenty-four hours of such accident, report in writing to the Engineer-In-Charge, the facts stating clearly and in sufficient details the circumstances of such accident and the subsequent action. All other accidents on the works involving injuries to person or damage to property other than that of the Contractor shall be promptly reported to the Engineer-In-Charge, stating clearly and in sufficient details the facts and circumstances of the accidents and the action taken. In all cases, the Contractor shall indemnify the owner against all loss or damage resulting directly or indirectly from the Contractor's failure to report in the manner aforesaid. This includes penalties or fines, if any, payable by the owner as a consequence of failure to give notice under the Workman's Compensation Act, or failure to conform to the provisions of the said act in regard to such accidents.

In the event of an accident in respect of which compensation may become payable under the Workman's Compensation Act VIII of 1923 including all modification thereof, the Engineer-In-Charge may retain out of money due and payable to the Contractor such sum of sums of money as may in the opinion of Engineer-In-Charge be sufficient to meet such liability. On receipt of award from the Labour Commissioner in regard to quantum of compensation, the difference in amount will be adjusted.

Asst.Engineer
R.M.C.

Dy.Ex. Engineer
R.M.C.

City Engineer
R.M.C.

PART-II
SECTION – 3
TECHNICAL SPECIFICATIONS

PART-II
SECTION - 3
TECHNICAL SPECIFICATIONS
CONTENT

SR NO	PARTICULARS	
A	GENERAL	
1	Scope of Contract	
2	e-TENDER Price	
3	Completion Schedule	
4	General Technical Guideline	
5	Classification of Strata	
B	DETAILED TECHNICAL SPECIFICATION	
B1	Material specification	
1	Providing and testing of SWG pipe	
2	Providing and testing of RCC NP3 pipe	
3	Providing and supplying precast M.H. & H.C.C. frame and cover	
4	Providing and supplying M.S. Frame, RCC Precast Sleeper Beam & Sleeper Covers for Scrapper Manhole.	
B2	Labour specification	
1	Excavation, Refilling and including removing of excavated stuff	
2	Providing and laying CC bedding for pipes	
3	Providing sand bedding for pipes	
4	Lowering ,laying and jointing of SWG and RCC NP3 pipe	
5	Removing surplus materials	
6	Appurtenances	
7	Breaking of Asphalt surface and re-instating of road	
C	GENERAL MATERIAL SPECIFICATION	
1	Concrete	
2	Form Work	
3	Reinforcement	
4	Brick Masonry	
5	Definition of Incomplete Work	
6	Contractor to observe all conditions	
D	ADDITIONAL CONDITIONS	
E	SCHEDULE OF DRAWING	

A. GENERAL

1. SCOPE OF CONTRACT :

The work entitled comprise of excavation of trenches with shoring and strutting wherever required bailing out water wherever necessary, laying of pipes, jointing including supply of material and material required for jointing, testing as per specifications, Construction of appurtenances such as brick Masonry Manholes , house chambers etc. as per the type design specified entirely of the specification of various works stipulated in the e-Tender. The work includes supply of sewer pipes i.e. R.C.C pipes and stone ware pipes of ISI Marked and R.C.C. precast manhole frames & covers which shall have to be supplied at site or Municipal store by the contractor at specified and shown in schedule "B". Other material like cement etc shall have to be supplied by the contractor from open market.

The pipes & R.C.C. precast manhole frames & covers shall be inspected by competent officer of RMC at Government approved laboratory as per the instructions of engineer in charge. All testing charges are to be borne by the contractor.

2. e-TENDER PRICE:

The rates quoted in the bill of quantities shall cover everything necessary for the due and complete execution of the work according to the drawings and other condition and stipulations of the contract including specifications of the evident, intend and meaning of all or either of them or according to customary usage and for periodical and final inspection and test and proof of the work in every respect and for measuring, numbering or weighing the same, including setting out and laying or fixing in position and the provision of all materials, power, tools, rammers, labour, tackle, platforms with impervious lapped joints for scaffolding, ranging roads, straight edged, cantering and boxing, wedges, moulds, templates, posts, straight rods, straight edged, cantering and boxing, wedges, moulds, templates, posts, straight rails, boning staves strutting, barriers, fencing lighting pumping apparatus, temporary arrangement for passage of traffic access to premises and continuance to drainage water supply and lighting (if interrupted by contractor's work) temporary sheds, painting, varnishing, polishing establishment for efficient supervision and stating arrangements for the efficient protective of life and property and all requisite plant and machinery of every kind.

The contractor shall keep every portion of the work clear of accumulation from time to time and shall leave every portion of the work clean, clear, perfect and at the conclusion of whole, providing at their own cost all such material implement, appliances and labour as the Engineer in charge may require to prove if it to be so.

3. COMPLETION SCHEDULE:

The contract period shall be as prescribed in tender document, which will be reckoned from the date of notice to proceed. The Contractor shall submit his completion schedule and the program of works together with his e-Tender in conformity with completion schedule given in the documents.

4. GENERAL TECHNICAL GUIDELINE:

- 4.1 All the items occurring in the work and as found necessary during actual execution shall be carried out in the best workman like manner as per specifications and the written order of the Engineer in charge
- 4.2 Extra Claim in respect of extra work shall be allowed only if such work is ordered to be carried out in writing by the Engineer in charge
- 4.3 The contractor shall engage a qualified Engineer for the Execution of work who will remain present for all the time on site and will receive instructions and orders from the Engineer in charge or his authorized representative. The instruction and orders given to the contractor representative on site shall be considered as it given to the contractor himself.
- 4.4 The work order book as prescribed shall be maintained on the site of the work by the contractor and the contractor shall sign the orders given by the inspecting officers and shall carry out them properly.
- 4.5 Quantities specified in the e-Tender may vary at the time of actual execution and the contractor shall have no claim for compensation on account of such variation
- 4.6 Unexcavated lengths shall be left wherever required and so directed by the Engineer in charge during the currency of the contract and shall be tackled. If required, before completion of work.
- 4.7 Diversion of road, if necessary, shall be provided and maintained during the currency of the contract by the contractor at his cost.
- 4.8 Figured Dimensions of drawing shall supersede measurements by scale, special dimensions or directions in the specifications shall supersede all other dimensions.
- 4.9 All levels are given on drawings and the contractor shall be responsible to take regular level on the approved alignment before actually starting the work. The levels shall be commence to the G.T.S. levels and shall be got approved from the Engineer in charge
- 4.10 If the arrangement of temporary drainage is required to be made during any work of this Contract, this shall be made by the Contractor without claiming any extra cost.

5 CLASSIFICATION OF STRATA:

- 5.1 All materials encountered in excavation will be classified in the following groups irrespective of mode of excavating the materials and the decision of the Engineer in charge in this regard shall be final and binding to the contractor.
- 5.2 Soils :
Soils of all sorts, silt, sand, gravel, soft murrum, stiff clay, kunkar and other soft excavation not covered in the items mentioned hereunder.
- 5.3 Hard Murrum :
Hard Materials comprising of all kinds of disintegrated rock or shale or indurate conglomerate interspersed with boulders, weathered and decomposed rock which could be removed with pick, bar, shove, wedges and hammers, though not without some difficulties.
- 5.4 Soft – Rock:
This shall include all materials which is rock but which does not need blasting and can be removed with a pick bar, wedges, pavement breakers, pneumatic tools etc.
- 5.5 Hard Rock:
This shall include rock accussing in mass or boulders which need blasting, this will also include rock to be removed by chiseling or any other method where blasting is not permissible.

Signature of contractor

B. DETAILED TECHNICAL SPECIFICATIONS

B1 MATERIAL SPECIFICATION

Inspection and testing of pipes at works shall be carried out as per IS: 3597: 1998 or its latest amendment for RCC NP3 pipe and IS: 651:2007 or its latest amendment for SWG pipes. No extra payment for testing of pipes at works shall be made. Contractor shall issue inspection call well in advance (min.7 days) to carry out testing of pipes. After successful testing of pipes, RMC or its representative shall give clearance for dispatch of pipes. Random Physical inspection of pipes at site will be carried out after delivery of pipes and if found any damage during transportation or due to any reason, pipes shall be rejected and same will not be used by contractor.

1. PROVIDING AND TESTING OF SWG PIPES AS PER THE TENDER SPECIFICATIONS.

1.1 TECHNICAL SPECIFICATION FOR S & S STONEWARE GLAZED PIPE.

All the specifications mentioned in the I.S Code 651-1992 & its latest revised addition shall be strictly followed.

1.1.1 In the revision of the above said code, grading based on Hydraulic test has been deleted and the standard monogram has also been modified and it appears as ISI symbol with IS: 651.

1.1.2 Tests for Acid & Alkali resistance for pipes and fittings which were earlier optional have now been made mandatory.

1.1.3 GLAZED STONEWARE PIPES AND FITTINGS:

1.1.3.1 This standard covers dimensions and performance requirements for the following glazed stoneware pipes and fittings:

- a) Straight pipes and taper pipes
- b) Bends
- c) Taper bend
- d) junctions
- e) half section channels, straight and taper
- f) channel junctions
- g) channel bends
- h) channel interceptors
- i) gully traps, and
- j) inspection pipes

1.1.3.1.1 The pipes as covered in this standard are not meant for potable water applications.

1.1.4 Dimensions of glazed stoneware pipes and fittings are grouped into two sections, A&B. Section-A covers dimensions of straight pipes and all such fittings which normally form part of pipeline and which are subject to same conditions, specifications and tests as straight pipes. Section-B includes dimensions of fittings which are commonly used

but do not form a part of the normal pipeline. The fittings in section-B being hand-moulded articles, their conformity to dimensional specifications is not required to be so accurate as for those in Section-A.

1.1.5 REFERENCES:

1.1.5.1 The following Indian Standards are the necessary adjunct to this standard.

IS No	Title
808 : 1989	Dimensions for hot rolled steel beam, column, channel and angle section (third revision)
2730 : 1977	Magnesium sulphate (Epsom salt) (first revision)
2781 : 19/5	Glossary of terms relating to ceramic ware (first revision)
4905 : 1968	Method for random sampling

1.1.6. TERMINOLOGY:

1.1.6.1 For the purpose of this standard, the definitions of terms given in IS 2781 : 1975 shall apply.

1.1.7. RIGHT-HAND AND LEFT-HAND FITTINGS:

1.1.7.1. A right-hand fitting is such that when viewed from the spigot towards the socket, the arm of a junction or the socket of a bend projects to the right (See Fig. 1A and 1B). a left-hand fitting is such that when viewed as above, the arm of socket projects to the left.

RIGHT-HAND FITTINGS

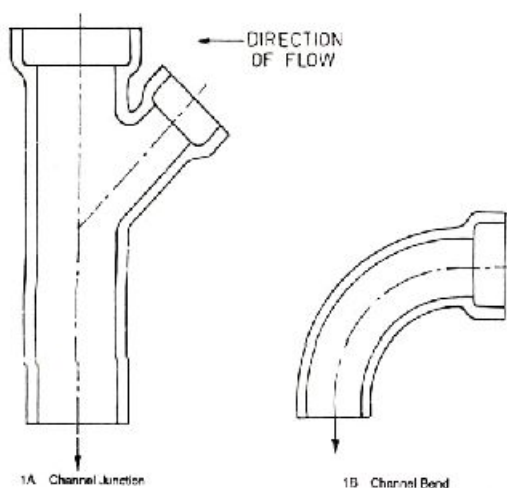

1.1.8 GENERAL QUALITY:

1.1.8.1. All pipes and fittings shall be sound and free from visible defects which impair the strength, durability and serviceability. The glazed of pipes and fittings shall give a sharp clear note when struck with a light hammer.

1.1.8.2. For pipes and fittings, a maximum of 10 percent shall be acceptable with any one of the following blemishes which do not impair the strength, durability and serviceability provided these pipes and fittings satisfactorily pass the hydraulic test specified in 4.1.10.2.

- a) A thin chipping not exceeding one quarter of the thickness of the body and not exceeding 10 cm² on the outside of spigot or on either side of the socket.
- b) One blister, unbroken, not more than 3 mm high not more than 40 mm in largest dimension inside or outside of the pipe; and
- c) Hairline surface cracks.

1.1.8.3. Colour of pipes / fittings may vary from yellow to dark brown / black.

1.1.9. GLAZING:

1.1.9.1. The interior and exterior surfaces of the pipes and fittings which remain exposed after jointing shall be glazed. The portion which remains covered after jointing may or may not be glazed. The glaze shall be obtained by the action of fumes of volatilized common salt on the material of the pipes and fittings during the process of burning or glazed shall be ceramic glaze consisting of glazing material applied prior to fixing.

1.1.10. TESTS:

1.1.10.1. Testing Facilities:

The manufacturer shall at his premises and at his own cost, provide the necessary gauges, supply and prepare all test pieces and supply all labour and apparatus for testing which may be necessary for carrying out the tests as required by this standard.

1.1.10.2. Hydraulic Test:

When subjected to the hydraulic test straight pipes shall withstand the internal hydraulic test pressure of 0.15 MPa (1 MPa = 10.2 kg/cm²) on the barrels and fittings covered in Section-A and 0.075 MPa for fittings covered in Section-B without showing signs of injury or leakage. The pressure shall be applied on pipes and fittings at a rate not exceeding 0.075 MPa in 5 seconds, and full pressure shall be maintained for at least 5 seconds. Care shall be taken to ensure that all air is expelled before the test is commenced.

1.1.10.3. Absorption Test:

The test pieces for testing shall be taken from the body of the pipe or fittings but not from within 150 mm of the end.

Each test pieces shall be of the whole thickness of the wall of the pipe or fittings and shall have two glazed surfaces each having an

area of not less than 50 cm² and not more than 130 cm². The test pieces shall be cleaned by wire brush to dislodge any loose particles which may increase loss of mass during boiling. The test piece shall be dried at a temperature of not less than 150°C until no further loss of mass is noted and cooled in a desiccators to the room temperature and the specimen weighed to an accuracy of 0.1 g. The test piece may be suitably suspended in cold distilled water by means of thread so that the test piece may not strike against each other or the container and incur loss in mass and the water in the container shall then be brought to the boiling point. The water shall be maintained at that temperature for 1 hour and after it has been allowed to cool to room temperature, the test pieces shall be removed carefully wiped with a dry cloth and then the mass determined. The percentage increase in mass of each test piece by absorption of water shall not exceed the following values:

Thickness of pipe or fitting mm	Increase in Mass percent
Up to and including 20	6
Over 20 and up to 25	7
Over 25 and up to 32	8
Over 32 and up to 38	9
over 38	10

1.1.10.4. Test for Acid Resistance:

Pipes and fittings shall be tested for acid resistance in accordance with the procedure given in Annexure-A. The loss in mass shall not exceed 2.5%.

1.1.10.5. Test for Alkali Resistance:

Pipes and fittings shall be tested to the action of magnesium sulphate in accordance with the procedure given in Annexure-B. There shall be no evidence of pitting, softening, spalling or cracking in the pipe or fitting after the test.

1.1.10.6. Crushing Strength Test:

When tested along the full length of the pipe barrel from shoulder to spigot in accordance with Annex. C, the pipe tested shall have a minimum crushing strength of 16 k N/m length.

1.1.11 SAMPLING AND CRITERIA FOR CONFORMITY:

1.1.11.1 The scale of sampling and the criteria for conformity of a lot shall be as prescribed in Annexure-D.

1.1.12. MARKING:

1.1.12.1 Every pipe and fitting shall have legibly impressed upon it before firing the following:

- a) Name or trade-mark of the manufacturer, and
- b) Size (Internal Dia.)

1.1.12.2 Each pipe and fitting may also be marked with the Standard Mark.

SECTION - A PIPES AND FITTINGS FORMING PART OF PIPE LINE

1.1.13 INTERNAL DIAMETER:

1.1.13.1 The internal diameter of the barrels of straight pipes, junctions and bends shall be as specified in col 1 of Table-1.

1.1.13.2 Permissible Tolerances:

The internal diameters specified in 4.1.13.1 shall be within the following tolerances:

Internal diameter of pipes mm	Permissible Tolerance mm
100	± 3
150	± 5
200, 230	± 6
250 to 350	± 8
400, 450	± 10
500, 600	± 12

Table-1 Dimensions of Barrels and Sockets
(Clauses 1.1.13.1, 1.1.13.2, 1.1.14.1, 1.1.16.1)
All Dimensions In Millimeters

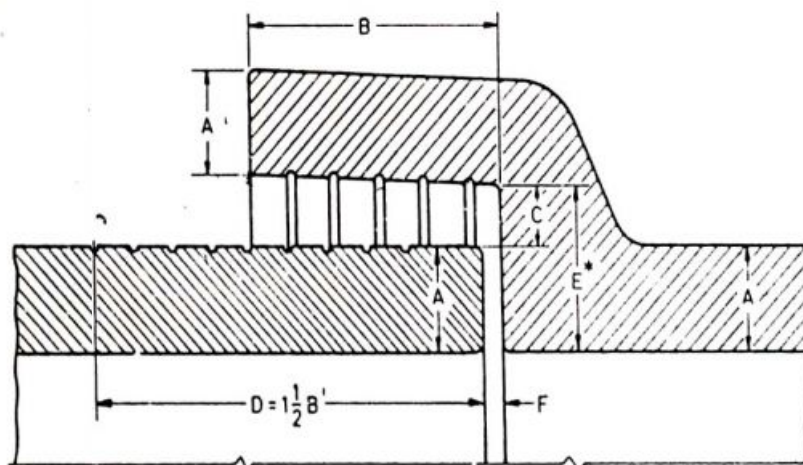

Internal Diameter	Mean Thickness of Barrel and Socket, Min A	a) Internal Depth of Socket, Min B	Excess shoulder Measurement, Min C	Length of Grooving of Spigot, Min D(1 1/2B)
1	2	3	4	5
100	12	50	10	75
150	15	57	11	85.5
200	16	63	12	94.5
230 +	19	63	12	94.5
250	20	70	16	105
300	25	70	16	105
350	30	75	16	112.5
400	35	75	16	112.5
450	37	76	16	14
500	40	80	19	120
600	43	90	19	135

- E = width of shoulder of socket which shall exceed the mean thickness of the barrel of the pipe (ascertained as directed in 4.1.14.1) by not less than the values for C given in col 4.
- + This is non-preferred size and has been included to facilitate replacements.

1.1.13.3 The pipes shall be inspected by Third Party Inspection Agency, the cost of which is to be borne by contractor. The Third Party Inspection Agency will be from any Government undertaking agency like RITES, EIL, CEIL, MACON, WAPCOS, SGS etc approved by Gujarat Water Supply & Sewerage Board..

1.1.14. THICKNESS OF BARRELS, SOCKETS AND BENDS:

1.1.14.1 The mean thickness of the barrel and the socket of the pipes junctions and bends shall not be less than the means thickness given in col 2 of Table 1. Such mean thickness of the barrels or sockets of any individual pipe junctions and bends shall be ascertained by making several minimum 4 measurements and adding the measured minimum thickness (not in the groove) to the maximum thickness and dividing the sum by two. The mean thickness of the barrel and socket shall be determined separately.

1.1.14.2. Permissible Variation:

The difference between the minimum and maximum measured thicknesses mentioned in 4.1.14.1 shall not exceed the amounts given below:

Internal diameter of pipe mm	Permissible variation in Thickness of Barrel and Sockets.mm
Not exceeding 450	2
500 and 600	3

ANNEX-A (Clause-
1.1.10.4.)
TEST FOR RESISTANCE TO ACIDS

A-0 PRINCIPLE:

A-0-1 The test specimen is completely immersed in the test solution and the resistance to acid is determined as the percentage of acid soluble matter expressed as sulphate.

A-1 REAGENTS:

A-1.1 Sulphuric Acid - 4.90 percent, specify gravity 1.84.

A-2 PREPARATION OF TEST SPECIMEN:

A-2.1 Test specimen shall be sound with all edges freshly broken, free from cracks or shattered edges, about 5 cm square, not more than 200 g in mass, and shall be thoroughly cleaned with wire brush.

A-3 WEIGHING APPARATUS:

A-3.1 The weighing shall be made on a balance accurate to 0.01 g when loaded with 200 g.

A-4 PROCEDURE:

A-4.1 The specimens to be tested shall be dried to a constant mass (M_1) at a temperature not less than 150°C. The specimens upon reaching constant mass shall be completely immersed in the test solution at the ambient temperature for a period of 48 hours. Then removed from the solution and carefully and thoroughly washed with hot distilled water, allowing the wash to run into the solution in which specimens were immersed. The solution shall be filtered and to the filtrate shall be added 5 ml of concentrated sulphuric acid. The solution shall then be evaporated (avoiding loss by ignition) and heated cautiously to dryness. It shall then be ignited to constant mass (M_2)

A-5 CALCULATION:

A-5.1 The percentage of acid soluble matter, expressed as sulphate shall be calculated as follows:

$$\text{Loss in mass \%} = \frac{\text{Mass of residue } (M_2)}{\text{Mass of dry specimen } (M_1)} \times 100$$

ANNEX-B
(Clause-1.1.10.5.)
TEST FOR ALKALI RESISTANCE

B-0 PRINCIPLE:

B-0.1 The resistance of stoneware pipes or fittings to alkali is determined by reaching it with magnesium sulphate solution.

B-1 PREPARATION OF SAMPLE":

B-1.1 Test samples measuring not less than 75 cm² and not more than 130 cm² shall be broken from the pipe or fittings. The samples shall be sound, free from cracks or surface defects.

B-2 REAGENTS:

B-2.1 Saturated Solution of Magnesium Sulphate - Conforming to IS: 2730 : 1977.

B-3 PROCEDURE:

B.3.1. Heat the magnesium sulphate solution (specific gravity 1.295 to 1.308) to the boiling temperature. Place the test sample in a wire basket and submerge it into the boiling solution; continue heating for two hours. then remove the sample and bring it to a constant mass in a drier or oven at a temperature not less than 110oC. Subject to the test sample to at least five cycles using fresh solution for each cycle. After the completion of five cycles remove the sample from the solution, wash it and bring it to constant mass in a drier or oven at a temperature not less than 110oC. Air cool the sample and observe.

B.3.2. There shall be no evidence of pitting, softening, spalling or cracking.

ANNEX-C (Clause-1.1.10.6.) CRUSHING STRENGTH TEST

C-1 CRUSHING STRENGTH TESTING MACHINE:

- C-1.1. While the pipe to be tested is supported in a horizontal position on two bearings parallel to its axis, the load shall be applied to it along the length of the barrel through a third bearing on top of the barrel (see Fig below).

CRUSHING TEST RIG

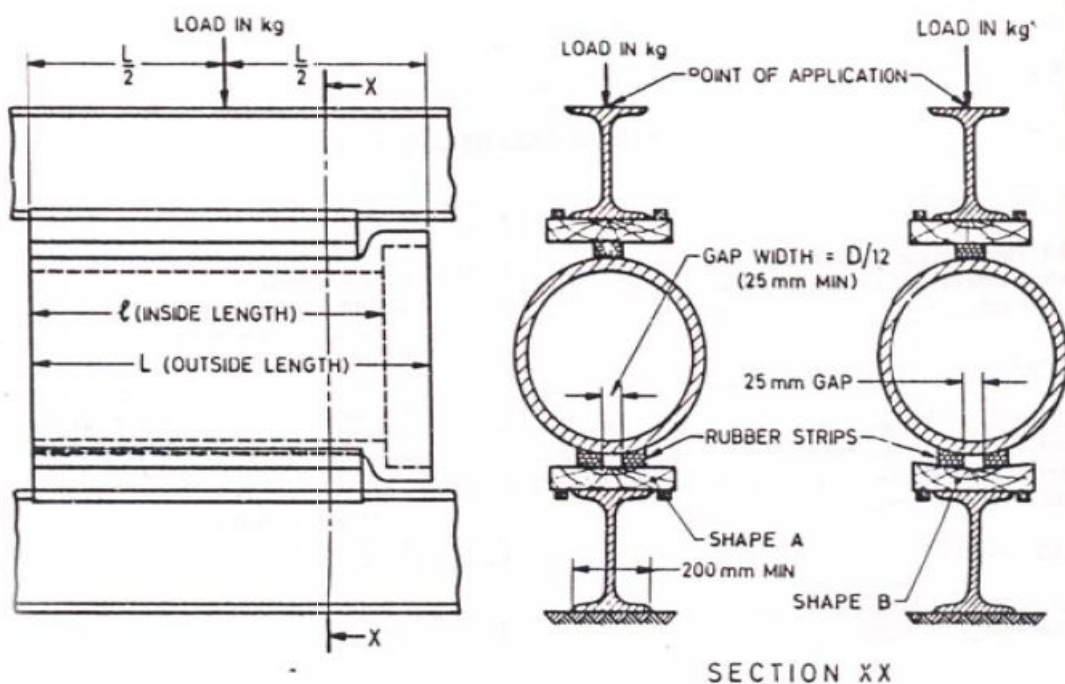

- C-1.2 Any testing machine having a device that will apply the load at a uniform rate of about 30 (kN/m) min. or in increments of not more than 500 N at the same rate, may be used for making the test.
- C-1.3 The testing machine shall be substantial and rigid throughout, so that the distribution of the load will not be affected appreciably by the deformation or yielding of any part. The bearings shall be as specified in C-1.4, C-1.5, C-1.6 and C-2.1, and shall be attached to the machine so as to receive and uniformly transmit maximum loads required in the tests without lost motion, vibrations, or sudden shock. The machine and bearings shall be designed to transmit the load in a vertical plane through the longitudinal center lines of the bearings and pipe.

- C-1.4 The three bearings shall consist of a lower member, being a rigid beam on which two bearing strips are symmetrically disposed parallel to a vertical plane passing through the longitudinal axis of the pipe, and an upper member also being a rigid beam, on which one bearing strip is centred and disposed so that it lies in the vertical plane passing through the longitudinal axis of the pipe (See Fig. Crushing Test Rig).
- C-1.5 The beam on which the bearing strips are disposed shall be structural steel beams single or of compound sections having moments of inertia about the vertical and horizontal axis of the cross section not less than those of WB 250 (See IS 808 : 1989) and with a width of flange not less than 200 mm.
- C-1.6 Mild steel, teak or similar hardwood shall be used to face the upper flange of the bottom beam. The facing shall be straight and free of warping or twisting and shall be centrally located on the flange of the beam by means of hardwood strips attached to its lower face and in contact with the edges of the flange. The cross section of the facing may have either of two shapes at the discretion of the pipe manufacturer.

Shape A shall be rectangular 280 x 25 mm minimum, without a joint. Shape B is shown in (Fig. DETAILS OF ALTERNATIVE FACING).

A similar facing of shape A may be used to face the lower flange of the upper beam if desired.

DETAILS OF ALTERNATIVE FACING

All dimensions in millimeters

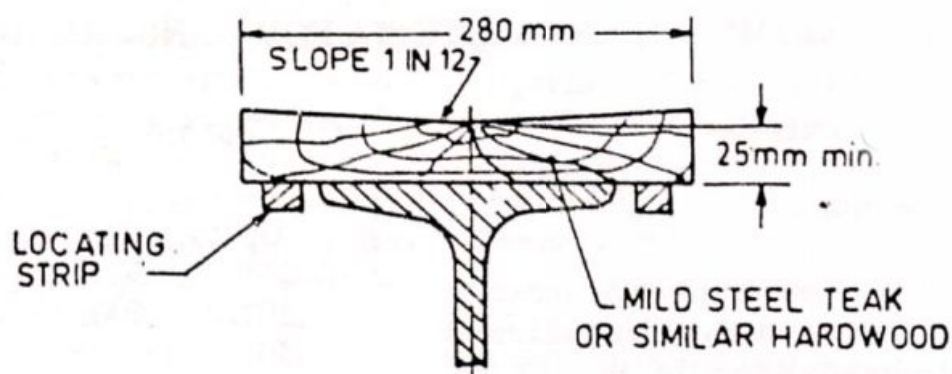

- C-2 BEARING STRIPS:
- C-2.1 The bearing strips shall consist of rubber cut or formed from material having sufficient hardness. The strips shall be of rectangular cross section having a width of 50 mm and a thickness of not less than 25 mm or more than 40 mm. The two bottom strips shall be of equal thickness.

- C-2.2 The single top bearing strip shall be used with the 50 mm dimension in contact with the pipe. It may be positioned on the bearing by the use of wood or metal strips along its outside edges, provided the thickness of the positioning strips does not exceed one-half the thickness of the rubber bearing strip.
- C-2.3 The two lower bearing strips shall be laid on the 50 mm dimension and may be positioned on the bearing with wood or metal strips between them and adjacent to their outside edges, provided the thickness of these positioning strips does not exceed one-half the thickness of these rubber bearing strips. The two strips shall be parallel and, when used with a facing of Shape A shall be spaced a distance apart of approximately 1 mm per 12 mm of pipe diameter but in no case has than 25 mm. When used with Shape B they shall be parallel and 25 mm apart for all pipe diameters.
- C-2.4 The rubber bearing strips may be attached to the facings, or in the case of the single upper strip, directly to the upper beam, by adhesive if desired, provided, such method of attachment results in the strip remaining firmly fixed in position when carrying the maximum load.
- C-3 APPLICATION OF LOAD:
- C-3.1 The load shall be applied to the top bearing at a point distant from the spigot and of the pipe equal to one-half of the overall length of the pipe including the socket if any. The test load shall be applied to the top bearing in such a way that the bearing is free to rotate in vertical plane through the longitudinal center line, of the top and bottom bearings. In testing a pipe that is not straight it shall be placed between the bearings in the position that appears to give the most favorable bearing conditions for fair test.
- C-3.2 The loading of the pipe shall be a continuous operation, and the pipe shall not be allowed to stand under load longer than is required to apply the load and record the observations.
- C-4 EVALUATION OF CRUSHING STRENGTH:
- C-4.1 The ultimate crushing strength in kN per linear metre shall be calculated by dividing the total applied load at fracture by the inside length of the barrel of the sample broken.

ANNEX-D
(Clause-1.1.11.1)
SAMPLING AND CRITERIA FOR CONFORMITY

D-1 SCALE OF SAMPLING:

D.1 Lot:

All the pipes or fittings of the same type, size and manufactured under similar conditions of production, shall be grouped together to constitute a lot.

D.2 The number of pipes or fittings to be selected at random from the lot depends upon the size of the lot and shall be in accordance with col 1 to 4 of Table 2.

D.3 NUMBER OF TESTS:

D.3.1 All the pipes or fittings selected as in D.2 shall be inspected for general quality (See 1.1.8.), dimensions (See Section A or Section B).

D.3.2. The number of pipes or fittings to be tested for hydraulic test (See 1.1.10.2.) shall be 5% of the lot as prescribed in D1. These pipes may be selected at random from those already selected in D.2 and suitable test specimens.

D.3.3 The number of pipes of fittings to be tested for absorption (1.1.10.3.) for resistance to action of acids (1.1.10.4.) and of alkali (See 1.1.10.5) and crushing strength (See 1.1.10.6.) shall be as given below:

Lot size	No.of pipes to be tested
Up to 150	3
151 to 1200	5
1201 to 10,000	8

These pipes may be selected at random from those already selected in D.2 and suitable test specimens shall be selected from them.

D.4 CRITERIA FOR CONFORMITY:

D.4.1 A lot shall be considered as conforming to the requirements of the specifications, if the conditions mentioned in D.4.2 to D.4.6 are all satisfied.

D.4.2. General Quality (See 1.1.8.) and Dimensions (See Section A and Section B).

The number of pipes and fittings in the first sample (See Col 2 and 3 of Table-2) shall be first selected and subjected to inspection for general quality and dimensions. If in the first sample the number of defectives, that is those failing either for general quality or dimensions, is less than or equal to the corresponding acceptance

number a_c (col 5 of Table-2), the lot shall be considered as conforming to the requirements of general quality and dimensions. If the number of defectives in the first sample is greater than or equal to the corresponding rejection number r_c (col 6 of Table-2), the lot shall be considered as not conforming. If the number of defectives in the first sample lies between the corresponding a_c and r_c a second sample (see col 2 and 3 of Table-2) shall be selected and subjected to inspection. If in the combined sample, the number of defectives is greater than or equal to the corresponding rejection number r_c the lot shall be considered as not conforming.

Table-2 : Sample Size and Criteria for Conformity
(Clause D.2)

Lot size	Sample	Sample Size	Cumulative sample size	General Quality (See 4.1.8) and dimensions Section a & B)	
				5	6
1	2	3	4	5	6
Upto 150	First Second	20 20	20 40	1 4	4 5
151 to 280	First Second	32 32	32 64	2 6	5 7
281 to 500	First Second	50 50	50 100	3 8	7 9
500 to 1200	First Second	80 80	80 160	5 12	9 13
1201 to 3200	First Second	125 125	125 250	7 18	11 19
3201 to 10,000	First Second	200 200	200 400	11 26	16 27

- D.4.3 For the hydraulic test, all the specimens shall satisfy the requirements as specified in 1.1.10.2.
- D.4.4 For water absorption test, the mean and range (difference between the highest and the lowest value) of the test results obtained shall be calculated and (mean + 0.6 range) shall be less than or equal to the maximum limit specified in 1.1.10.3.
- D.4.5. For resistance to action of acids and of alkali shall satisfy the requirements specified in 1.1.10.4. and 1.1.10.5. respectively.
- D.4.6 For crushing strength test all the test specimen shall satisfy the requirement as specified in 1.1.10.6.

2. PROVIDING AND TESTING OF RCC PIPES AS PER THE TENDER SPECIFICATIONS.

2.1 SCOPE

All the specifications mentioned in the I.S Code 458-2003 & its latest revised addition shall be strictly followed.

- 2.1.1 This standard covers the requirements for reinforced unreinforced precast cement concrete pipes, of both pressure and non – pressure varieties used for water mains, sewers, culverts and irrigation. The requirements for collars are also covered by this standard.

NOTES

- 1 This standard covers the requirements for pressure and also non – pressure pipes of class NP3 and NP4 manufactured by vibrated casting process.
- 2 In addition to the requirements specified specifically for the collars, the requirements given in the following clause shall also apply for the collars:

2.5.2,2.5.3,2.5.4,2.5.5.1,2.5.5.3,2.5.5.4,2.5.7,2.5.8,2.7.1,2.7.2,2.7.2.1,2.7.2.2.,2.7.3,2.7.3.1,2.7.4,2.8.2,2.9.1,2.9.1.1,2.9.1.2,2.9.1.3,2.9.1.4, 2.12.1 and 2.12.1.1.

- 2.1.2 Pre-stressed concrete pipes and pipes with non-circular section are not covered by this standard

2.2 TERMINOLOGY

2.2 For the purpose of this standard, the following definitions shall apply.

- 2.2.1 Working Pressure – The maximum sustained internal pressure excluding surge, to which each portion of the pipeline may be subjected when installed.
- 2.2.2 Site Test Pressure – 1.5 times working pressure pertaining to the section or 1.1 times static pressure. Whichever is more (surge pressure is to be controlled within 25 percent pump head in case of pumping mains).
- 2.2.3 Hydrostatic Test Pressure – It is the maximum pressure which the pipe can withstand without pressure which the pipe can withstand without any leakage when tested for hydrostatic pressure in accordance with this standard and IS 3597.
- 2.2.4 Surge (Water Hammer) Pressure – It is a pressure which is produce by a change of velocity of the moving stream and becomes maximum when there is a sudden stoppage which may be caused by the closing of a valve or by shutting down a pump station. Surge head.

2.3 CLASSIFICATION

2.3.1 For the purpose of this standard, concrete pipes shall be classified as under:

Class	Description	Conditions Where Normally Used
NP1	Unreinforced concrete non – pressure pipes	For drainage and Irrigation use, above ground or in shallow trenches
NP2	Reinforced concrete, light – duty, non – pressure pipes	For drainage and irrigation use, for cross drains/culverts carrying light traffic
NP3	Reinforced and also unreinforced (in case of pipes manufactured by vibrated casting process) concrete, medium – duty, non – pressure pipes.	For drainage and irrigation use, for cross drains / culvert carrying heavy medium traffic
NP4	Reinforced and also unreinforced (in case of pipes manufactured by vibrated casting process) concrete, heavy – duty, non – pressure pipes	For drainage and irrigation use, for cross drain/culvert carrying heavy traffic
P1	Reinforced concrete pressure pipes tested to a hydrostatic pressure of 0.2 MPa (20m head)	For use on gravity mains, the site test pressure not exceeding two – thirds of the hydrostatic test pressure
P1	Reinforced concrete pressure pipes tested to a	For use on pumping mains the site test
P1	Reinforced concrete pressure pipes tested to a hydrostatic pressure of 0.4 MPa (40m head)	For use on pumping mains, the site test pressure not exceeding half of the hydrostatic test pressure
P3	Reinforced concrete pressure pipes tested to a hydrostatic pressure of 0.6 MPa (60m head)	For use on pumping mains, the site test pressure not exceeding half of the hydrostatic test pressure

Note –The uses are only by way of recommendations as a general guidance and the exact usage shall be decided by the engineer – in – charge.

2.3.2 Unreinforced and reinforced concrete non-pressure pipes shall be capable of withstanding a test pressure of 0.07 MPa (7m head).

2.4 MATERIALS

2.4.1 For precast concrete pipes, materials complying with the requirements given in 2.4.2 to 2.4 .8 shall be used.

2.4.2 Cement

Cement used for the manufacture of unreinforced and reinforced concrete pipes shall conform to IS 269 or IS 455 or IS 1489 (Part 1) (see Note 1) or IS 1489 (Part 2) or IS 8041 or IS 8043 or IS 8112 or IS 12269 or IS 12330.

NOTES

1. Unless otherwise specified by the purchaser, the type of cement to be used is left to the discretion of the manufacturer. Fly ash based cement conforming to IS 1489 (Part 1) with fly ash contents up to 25 percent is permitted for non-pressure pipe only.
2. Sulphate resisting Portland cement (see IS 12330) shall be used, where sulphate is predominant.
3. Site blending with fly ash up to a maximum of 25 percent may be carried out provided its uniform blending with ordinary Portland cement is ensured. Such blended cement shall be used only for non-pressure pipes. The fly ash used for blending shall be either from ESP or processed by established fly ash processing units and shall conform to Grade 1 of IS 3812. Specified requirements of concrete strength, permeability, hydrostatic test and three -edge bearing test shall be met to the satisfaction of customer before it is used for regular production.

2.4.3 Aggregates

Aggregates used for the manufacture of unreinforced and reinforced concrete pipes shall conform to 3 of IS 383. The maximum size of aggregates should not exceed one third thickness of the pipes or 20 mm, whichever is smaller for pipes above 250 mm internal diameter. But for pipes of internal diameter 80 to 250 mm the maximum size of aggregates should be 10 mm.

NOTE:- It is preferable to have the size and grading of aggregates conforming to IS 383. It is also preferable that materials finer than 75 micron IS Sieve is restricted to 3.0 percent by mass.

2.4.4 Reinforcement

Reinforcement used for the manufacture of the reinforced concrete pipes shall conform to mild steel Grade 1 or medium tensile steel bars conforming to IS 432 (Part 1) or hard-drawn steel wire conforming to IS 432 (Part 2) or structural steel (standard quality) bars conforming to IS 2062.

NOTE :- Wire fabric conforming to IS 1556 or deformed bars and wires conforming to IS 1786 or plan hard -drawn steel wire for pre-stressed concrete to IS 1785 (Part 1) or IS 1785 (Part 2) may also be used. For such reinforcement maximum tensile stress shall be as given in 6.1.

2.4.5 Concrete Mortar

2.4.5.1 The concrete quality (concrete mix, maximum water-cement ratio, minimum cement content, etc) shall be as per IS 456 for at least very severe environment exposure condition. Design mix requirements shall be as per IS 456. However, in case of pipes cast by spinning process higher cement contents, more fines and higher water-cement ratio may be the need of the process. For non-pressure pipes, if mortar is used, it shall have a minimum cement content of 450 kg/m³ and a compressive strength not less than 35 N/mm² at 28 days. For pressure pipes if mortar is used, it shall have a minimum cement content of 600 kg/m³ and a compressive strength not less than 35 N/mm² at 28 days. However, in case of pipes manufactured by vibrated casting process, concrete shall minimum compressive strength as indicated in Tables 4, 5, 7 and 8 for the respective classes of pipes.

Where the process of manufacture is such that the strength of concrete or mortar in the pipe differs from that given by tests on cubes, the two may be related by a suitable conversion factor. If the purchaser requires evidence of this factor, he shall ask for it before placing the order. The conversion factor for 28 days compressive strength for spun concrete may be taken as 1.25 in the absence of any data.

2.4.5.2 For pressure pipes, splitting tensile strength of concrete cylinders at 28 days, when tested in accordance with IS 5816, shall be not less than 2.25 N/mm².

2.4.5.3 Compressive strength tests shall be conducted on 150 mm cubes in accordance with the relevant requirements of IS 456 and IS 516.

2.4.5.4 The manufacture shall give a certificate indicating the quantity of cement in the concrete mix.

2.4.6 Rubber Ring

Rubber ring chords used in pipe joints shall conform to Type 2 of IS 5382.

2.4.7 Water

Water used for mixing of concrete and curing of pipes shall conform to 5.4 of IS 456.

2.4.8 Chemical Admixtures

The admixtures, where used, shall conform to IS 9103.

2.5 DESIGN

2.5.1 General

Reinforced concrete pipes either spun or vibrated cast shall be designed such that the maximum tensile stress in the circumferential steel due to specified hydrostatic test pressure does not exceed the limit of 125 N/mm² in the case of mild steel rods, 140 N/mm² in the case of hard-drawn steel wires and high strength deformed steel bars and wires.

2.5.1.1 The barrel thickness shall be such under the specified hydrostatic test pressure, the maximum tensile stress in concrete, when considered as effective to take stress along with the tensile reinforcement, shall not exceed 2 N/mm² for pressure pipes and 1.5 N/mm² for non-pressure pipes. But the barrel wall thickness shall be not less than those given in Table 1 subject to 2.7.2 (iii) for pipes manufactured by spun process. For pipes manufactured by vibrated casting process, the barrel wall thickness shall be as given in Table 2, 3

2.5.1.2 Pipes of length above 3 m and up to 4 m may be supplied by agreement between the user and the supplier and for such pipes, the quantity of reinforcement shall be modified as per 2.5.1.2.1

2.5.1.2.1 Longitudinal reinforcement

Reinforced cement concrete pipes of lengths up to 4 m may be accepted if the longitudinal reinforcement is increased in proportion to the square of length compared with what is used for 3 m length as specified in Tables 1 and 3, except for Table 2

For 'L' (in metre) length of pipe, longitudinal reinforcement shall be $L^2/3^2$ times the longitudinal reinforcement used for 3 m long pipes.

2.5.1.3 Longitudinal reinforcement shall be provided to ensure rigidity and correct location of cages (girds) longitudinally and to limit the effects of transverse cracking. Minimum longitudinal reinforcement shall be as given in Table 1 for pipes manufactured by spinning process. For reinforced pipes manufactured by vibrated casting process, the minimum longitudinal reinforcement shall be as given in Table 3

2.5.2 Reinforcement

The reinforcement in the reinforced concrete pipe shall extend throughout the length of the pipe and shall be so designed that it may be readily placed and maintained to designed shape and in the proper position within the pipe mould during the manufacturing process. The circumferential and longitudinal reinforcement shall be adequate to satisfy the requirements specified under 2.5.1.

For non-welded cages spiral reinforcement of the same diameter shall be closely spaced at the end of the pipe for a length of 150 mm to minimize damage during handling. The spacing of such end spirals shall not exceed 50 mm or half the pitch whichever is less. Such spiral reinforcement at ends shall be part of the total spiral reinforcement specified in different tables.

2.5.2.1 The pitch of circumferential reinforcement shall be not more than the following:

- a) 200 mm for pipes of nominal internal diameter 80 to 150 mm.
- b) 150 mm for pipes of nominal internal diameter 200 to 350 mm, and
- c) 100 mm for pipes of nominal internal diameter 400 mm and above.

The pitch shall also be not less than the maximum size of aggregate plus the diameter of the reinforcement bar used.

2.5.2.2 The quantity and disposition of steel in pipes may be decided by mutual agreement between the purchaser and the supplier; however, it shall be proved by calculations and tests that the quantity of the reinforcement conforms to all the requirements specified in the standard. In the absence of calculations and tests, the reinforcement given in Table 1 for pipes manufactured by spinning process and in Table 3 for pipes manufactured by vibrated casting process shall be used as minimum reinforcement subject to the requirements of 2.5.2.2.1.

2.5.2.2.1 Tolerances given in IS 432 (part 1), IS 432 (Part 2), and IS 2062 shall be applied to the minimum mass to longitudinal reinforcement specified in different tables. Total mass of longitudinal reinforcement shall be calculated taking into account the clear cover provided at each end of the pipe.

NOTE : For longitudinal reinforcement conforming to IS 432 (Part 2), tolerance on mass shall be calculated from the diameter tolerance.

2.5.2.3 If so required by the purchaser, the manufacturer shall give a certifying the details relating to quality, quantity and dispersion of steel in the pipes as well as the clear cover to the steel provided in the pipes.

2.5.3 Ends of Pipes

Spigot and Socket ended pipes shall be used for water mains, sewer, irrigation and culverts/cross drains. Whereas, flush jointed (NP3 and NP4) and collar jointed (NP2) pipes shall be used for culverts/cross drains only. The ends of concrete pipes used for water mains, sewer and irrigation shall be suitable for socket and spigot, roll on joints or confined gasket joints. Dimensions of spigot and socket for various classes of pipes shall be as given in Table 4,5 for pipes manufactured by spinning process. However the dimensions of spigot and socket shall be as given in Tables 6 in case of pipes manufactured by vibrated casting process. Reinforcement in socket of rubber ring jointed pipes shall be as given in Table 7.

However, the ends of concrete pipes used for road culverts/cross drains may be suitable for flush (NP3 and NP4) or collar joints (NP2) (see Fig.1 and 2). For pipes of diameter up to 700 mm, external flush joint and for diameters above 700 mm, internal flush joint is recommended.

NOTES

1. Bends, junctions and specials for concrete pipes covered under this standard shall conform to the requirements of IS 7322.
2. Same typical arrangement of reinforcement in socket are illustrated in Fig. 3 and Fig.4.

2.5.3.1 Only flexible rubber ring joints shall be used for the joints in (a) all pressure pipes and (b) all non-pressure pipes except when used for road culverts/cross drains. The pipe joints shall be capable of withstanding the same pressure as the pipe.

NOTE : The requirements of 2.5.3.1 does not imply that the collar shall also be tested for the test pressure for pipes specified in 2.3.1, 2.3.2 and 2.9.

2.5.4 Cover

The minimum clear covers for reinforcement in pipes and collars shall be as given below:

SI NO	Precast Concrete Pipe/Collar	Minimum Clear Cover, mm
i)	Barrel wall thickness :	
	a) Up to and including 75 mm	8
	b) Over 75 mm	15
ii)	At spigot steps	5
iii)	At end of longitudinal	5

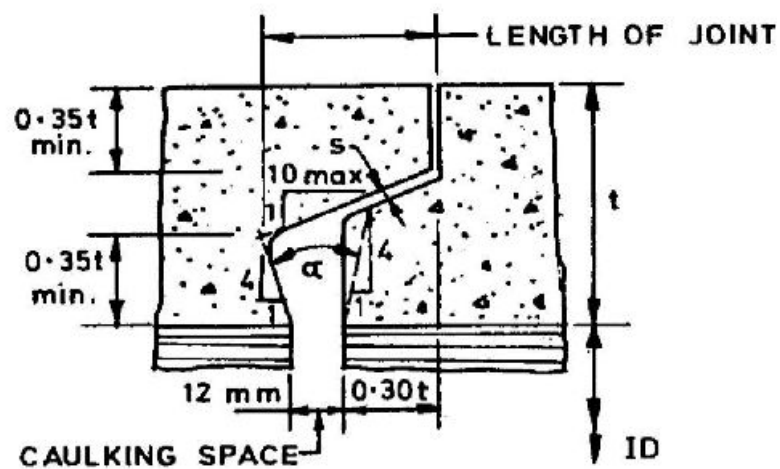

1A Internal Flush Joints

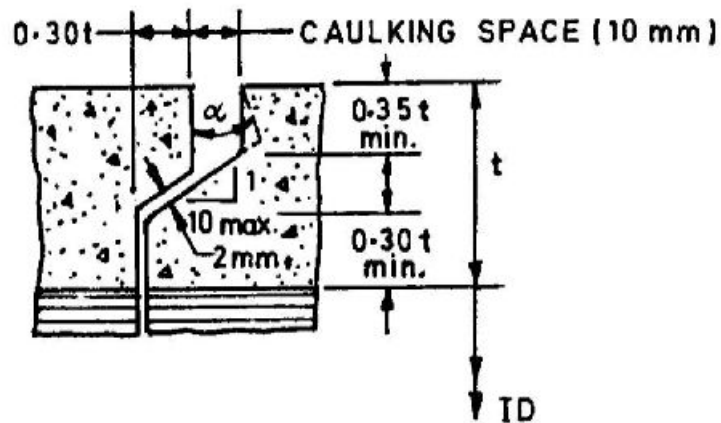

1B External Flush Joints

- t – wall thickness.
 s – 0.002 of internal dia or 2 mm, *Min.*
 ID – internal diameter.
 α – included angle not more than 25° (only for design purp not be measured).

Fig. 1 DETAILS OF FLUSH JOINT

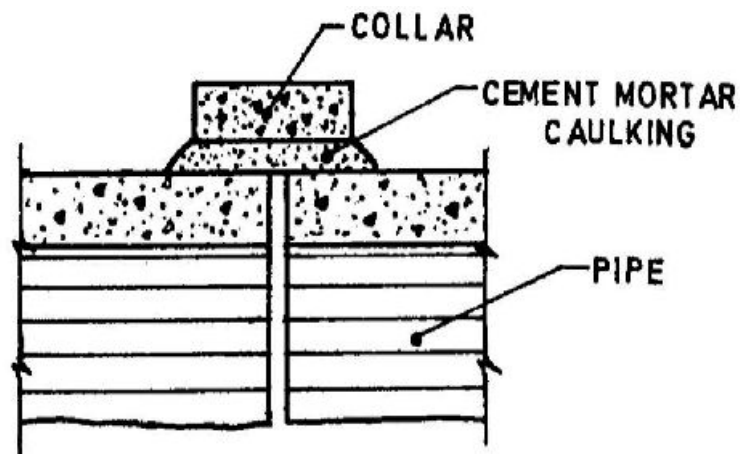
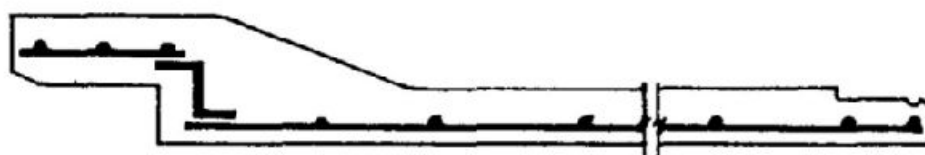

FIG-2 COLLOR JOINT(RIGID)

NOTE : - An effective means shall be provided for maintaining the reinforcement in position and for ensuring correct cover during manufacture of the unit. Spacers for this purposes shall be of rustproof materials or of steel protected against corrosion.



NOTE — No. of Z bars : Minimum half the number of longitudinals.
Maximum equal to number of longitudinals.

**3A Socket Cage Connected to Barrel
Cage by Means of Z Bars**

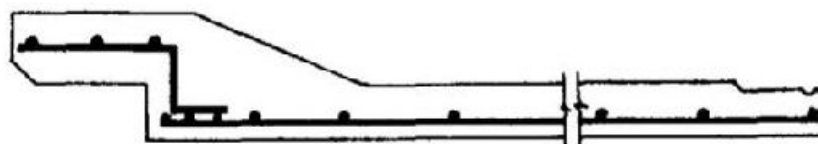

**3B Socket Cage Longitudinals Suitably Bent
for Connecting to Barrel Cage**

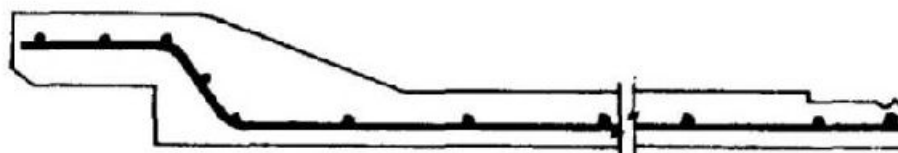

3C Cage made of Continuous Longitudinals

**FIG. 3 TYPICAL ARRANGEMENTS OF REINFORCEMENT
IN SOCKET FOR SINGLE CAGE**

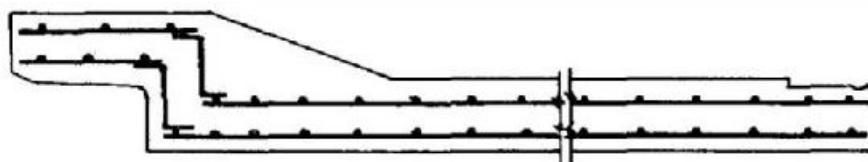

NOTE — No. of Z bars : Minimum half the number of longitudinals.
Maximum equal to number of longitudinals.

**4A Socket Cage Connected to Barrel
Cage by Means of Z Bars**

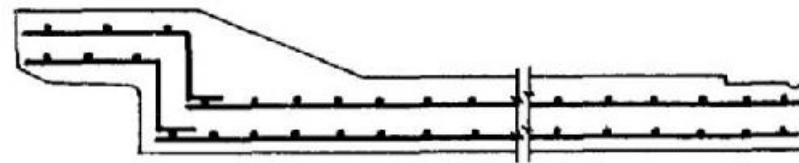

4B Socket Cage Longitudinal Suitably Bent for Connecting to Barrel Cage

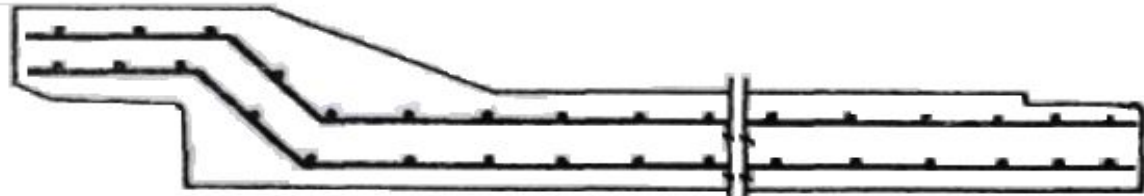

4C Cage made of Continuous Longitudinal

Fig 4. Typical arrangements of reinforcement in socket for double cage (use suitable type of spacers)

2.6 MANUFACTURE

2.6.1 General

The method of manufacture shall be such that the forms and dimensions of the finished pipe are accurate within the limits specified in this standard. The surfaces and the limits specified in this standard. The surfaces and edges of the pipes shall be well defined and true, and their ends shall be square with the longitudinal axis.

2.6.2 Concrete Mixing and Placing

2.6.2.1 Concrete shall be mixed in a mechanical mixer. Mixing shall be continued until there is a uniform distribution of the materials and the mass is uniform in colour and consistency, but in no case shall the mixing be done for less than 2 min.

2.6.2.2 Concrete shall be placed before setting has commenced. It should be ensured that the concrete is not dropped freely so as to cause segregation. The concrete shall be consolidated by spinning, vibrating, spinning combined with vibrations, or other appropriate mechanical means.

2.6.3 Reinforcement Cages

Reinforcement cages for pipes shall extend throughout the pipes barrel. The cages shall consist of spirals or circular rings and straights of hard-drawn steel wire or mild steel rod. Reinforcement cages shall be placed symmetrically with respect to the thickness of the pipe wall. The spirals shall end in a complete ring at both the ends of a pipe.

2.6.3.1 Pipes having barrel wall thickness 100 mm and above shall have double reinforcement cage and the amount of spirals steel in the outer cage shall be 75 percent of the mass of spiral steel in the inner cage, whilst the total shall conform to the

requirements specified in the relevant tables of this standard. The mass of longitudinals in the outer cage and inner cage should be the same, that is equal to half the total mass of longitudinals steel per pipe shall be given in the relevant tables.

NOTES : It is preferable that single reinforcement cage should be located near the inner surface of the pipe with adequate clear cover.

2.6.3.2 Diagonal reinforcement may be provided in pipes, the cages for which are not welded so as to help in binding the cage securely. It shall, however, be ensured that the clear cover for any reinforcement is not below the limits specified in 2.5.4. Diagonal reinforcement is a process requirement and shall not be counted against longitudinal and spiral reinforcement.

2.6.4 Curing

Curing shall be either by steam or by water or by a combination of steam and water, or by use of approved curing compounds. If water curing is used, the pipes shall be cured for a minimum period of 7 days in case of non-pressure pipes and 14 days in case of pressure pipes. In case of pipes where cement with fly ash or slag is used, the minimum period of water curing shall be 14 days, if steam curing is used, after that is shall be water cured for 3 days.

2.7. DIMENSIONS

2.7.1 Pipes

The internal diameter, barrel wall thickness, length, the minimum reinforcement and strength test requirements for different classes of pipes (see 2.2.1), shall be as specified in Table 1 to 3. However, in case of pipes manufactured by vibrated casting process, the internal diameter, wall thickness, the minimum reinforcement (in case of reinforced pipes) and strength test requirements for different classes of pipes shall be as given in Table . The manufacturer shall inform the purchaser of the effective length of spigot and socket, and flush jointed pipes that he is able to supply. For collar jointed pipes, effective length shall be 2 m or 2.5 m up to 250 mm nominal diameter pipes and 2.5 m, 3.0 m or 4.0 m for pipes above 250 mm nominal diameter 900 mm and above, the effective length may also be 1.25 m.

NOTES : Pipes of internal diameter, barrel wall thickness and length of barrel and collar other than those specified in 2.7.1 may be supplied by mutual agreement between the purchaser and the supplier. In such case, the design of pipes submitted to the purchaser shall include all standard details as covered in Tables 1 to 3.

2.7.2 Tolerances

The following tolerances shall be permitted:

Sr No.	Dimensions		Tolerances
i)	Overall length	:	± 1 percent of standard length
ii)	Internal diameter of pipes	:	
	a) Up to and including 300 mm	:	$\pm 3^{\text{mm}}$
	b) Over 300 mm and up to and including 600 mm	:	$\pm 5^{\text{mm}}$
	c) Over 600 mm	:	$\pm 10^{\text{mm}}$
iii)	Barrel wall thickness	:	
	a) Up to and including 30 mm	:	+ 2^{mm} - 1^{mm}
	b) Over 30 mm up to and including 50 mm	:	+ 3^{mm} - 1.5^{mm}
	c) Over 50 mm up to and including 65 mm	:	+ 4^{mm} - 2^{mm}
	d) Over 65 mm up to and including 80 mm	:	+ 5^{mm} - 2.5^{mm}
	e) Over 80 mm up to and including 95 mm	:	+ 6^{mm} - 3^{mm}
	f) Over 95 mm	:	+ 7^{mm} - 3.5^{mm}

NOTE - In case of pipes with flexible rubber ring joints, the tolerance on thickness near the ends will have to be reduced. Near the rubber ring joints, the tolerance on thickness shall be as given in Tables 4 to 6 in case of pipes manufactured by spinning process and as given in Table 5 in case of pipes manufactured by vibrated casting process.

2.8 WORKMANSHIP AND FINISH

2.8.1 Finish

Pipes shall be straight and free from cracks except that craze cracks may be permitted. The ends of the pipes shall be square with their longitudinal axis so that when placed in a straight line in the trench, no opening between ends in contact shall exceed 3 mm in pipes up to 600 mm diameter (inclusive), and 6 mm in pipes larger than 600 mm diameter.

2.8.1.1 The outside and inside surfaces of the pipes shall be dense and hard and shall not be coated with cement wash or other preparation unless otherwise agreed to between the purchaser and the manufacturer or the supplier. The inside surface of the pipe shall be smooth. For better bond, inner surface of the collar may be finished rough.

Table 1 Design and Strength Test Requirements of Concrete Pipes of Class NP3 – Reinforced Concrete, Medium Duty, Non – pressure Pipes

(Clauses 2.5.1.1, 2.5.1.2.1, 2.5.1.3, 2.5.2.2, 2.5.3.2 and 2.7.1; and Table 7)

Internal Diameter of Pipes	Barrel Wall Thickness	Reinforcements			Strength Test Requirement for Three Edge Bearing Test	
		Longitudinal, Mild Steel or Hard Drawn Steel	Spirals, Hard Drawn Steel	Load to Produce	Ultimate Load	
mm	mm	Minimum number	Kg / linear meter	kg / linear meter	0.25 mm Crack kN/linear meter	kN / liner meter
(1)	(2)	(3)	(4)	(5)	(6)	(7)
300	40	8	0.78	1.80	15.50	23.25
350	75	8	0.78	2.95	16.77	25.16
400	75	8	0.78	3.30	19.16	28.74
450	75	8	0.78	3.79	21.56	32.34
500	75	8	0.78	4.82	23.95	35.93
600	85	8 or 6+6	1.18	7.01	28.74	43.11
700	85	8 or 6+6	1.18	10.27	33.53	50.30
800	95	8 or 6+6	2.66	13.04	38.32	57.48
900	100	6+6	2.66	18.30	43.11	64.67
1000	115	6+6	2.66	21.52	47.90	71.85
1100	115	6+6	2.66	27.99	52.69	79.00
1200	120	8+8	3.55	33.57	57.48	86.22
1400	135	8+8	3.55	46.21	67.06	100.60
1600	140	8+8	3.55	65.40	76.64	114.96
1800	150	12+12	9.36	87.10	86.22	129.33

NOTE :

1. If mild steel is used for spiral reinforcement, the weight specified under col 5 shall be increased to 140/125
2. The longitudinal reinforcement given in this table is valid for pipe up to 2.5m effective length for internal diameter of pipe up to 250mm and up to 3m effective length for higher diameter pipes
3. Total mass of longitudinal reinforcement shall be calculated by multiplying the value given in col 4 by the length of the pipe and then deducting for the cover length provided at the two ends.
4. Concrete for pipes shall have a minimum compressive strength of 35 N/mm² at 28 days.

Table 2 Design and Strength Test Requirement of Concrete Pipes of Class NP3 – Un reinforced Concrete, Medium – Duty, Non – pressure Pipes Made by Vibrated Casting Process (Clauses 2.4.5.1, 2.5.1.1, 2.5.3 and 2.7.1 and Table 7)

Internal Diameter of Pipes	Minimum Barrel Wall Thickness	Strength Test Requirement for Three Edge Bearing Test, Ultimate Load
mm	mm	kN Bearing Test, Ultimate Load
(1)	(2)	(3)
300	50	15.50
350	55	16.77
400	60	19.16
450	65	21.56
500	70	23.95
600	75	28.74
700	85	33.53
800	95	38.22
900	100	43.11
1000	115	47.90
1100	120	52.69
1200	125	57.48
1400	140	67.06
1600	165	76.64
1800	180	86.22

NOTE – Concrete for pipes shall have a minimum compressive strength of 45 N/mm² at 28 days.

Table 3 Design and Strength Test Requirements of Concrete Pipes of Class NP3 – Reinforced

Concrete, Medium Duty, Non – pressure Pipes made by vibrated casting process

(Clauses 2.4.5.1., 2.5.1.1, 2.1.2.1, 2.5.1.3, 2.5.2.2, 2.6.3.2 and 2.7.1; and Table 7)

Internal Diameter of Pipes	Minimum Barrel Wall Thickness	Reinforcements			Strength Test Requirement for Three Edge Bearing Test	
		Longitudinal, Mild Steel or Hard Drawn Steel		Spirals, Hard Drawn Steel	Load to Produce	Ultimate Load
mm	mm	Minimum number	Kg / linear meter	kg / linear meter	0.25mm Crack kN/linear meter	kN / liner meter
(1)	(2)	(3)	(4)	(5)	(6)	(7)
300	50	8	0.78	1.53	15.50	23.25
350	55	8	0.78	1.58	16.77	25.16
400	60	8	0.78	1.60	19.16	28.74
450	65	8	0.78	1.90	21.56	32.34
500	70	8	0.78	2.0	23.95	35.93
600	75	8 or 6+6	1.18	2.20	28.74	43.11
700	85	8 or 6+6	1.18	4.87	33.53	50.30
800	95	8 or 6+6	2.66	6.87	38.32	57.48
900	100	6+6	2.66	11.55	43.11	64.67
1000	115	6+6	2.66	15.70	47.90	71.85
1100	120	6+6	2.66	19.61	52.69	79.00
1200	125	8+8	3.55	21.25	57.48	86.22
1400	140	8+8	3.55	30.00	67.06	100.60
1600	165	8+8	3.55	50.63	76.64	114.96
1800	180	12+12	9.36	64.19	86.22	129.33
2000	190	12+12	9.36	83.12	95.80	143.70
2200	210	12+12	9.36	105.53	105.40	158.07
2400	225	12+12	14.88	133.30	115.00	172.44

NOTE: - Concrete for pipes shall have a minimum compressive strength of 35 N/mm² at 28 days.

Table 4 Spigot and Socket Dimensions of NP3 and NP4 Class Pipes (Rubber Ring Roll on Joint) from 80 to 900 mm Diameter (Clauses 2.5.3 and 2.7.2)

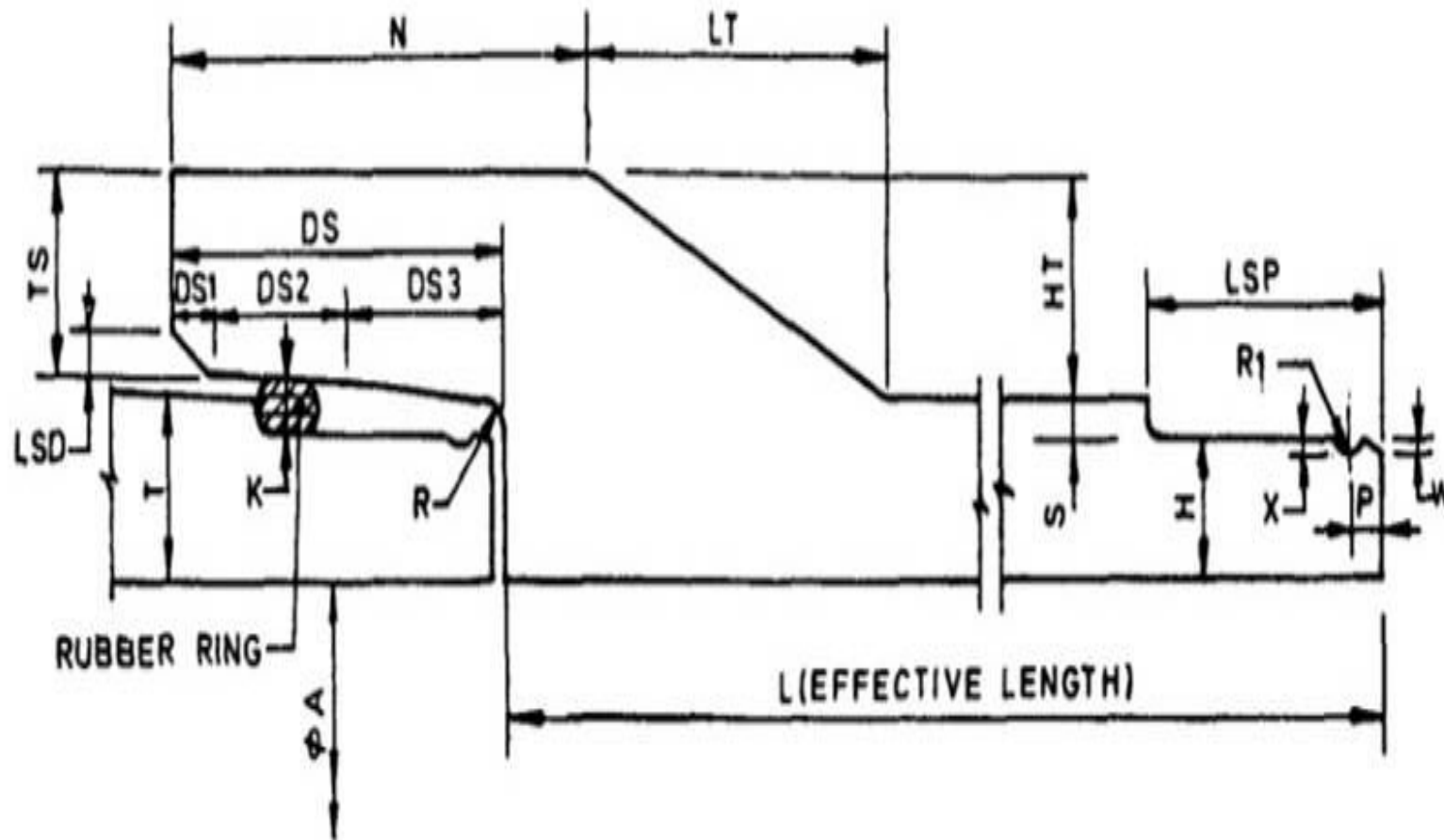

All dimensions in millimeters

Pipe Diameter A	Rubber Ring Chord Diameter	Rubber Ring Internal Diameter	T	TS	DS	DS1	DS2	DS3	R	LSD	K	N	LT	HT	LSP	P	S	H	X	W	R1
(1)	(2)	(3)	(4)	(5)	(6)	(7)	(8)	(9)	(10)	(11)	(12)	(13)	(14)	(15)	(16)	(17)	(18)	(19)	(20)	(21)	(22)
80	11	102	25	32.5	70	8	28	34	3	5.5	6.5	95	84	34	50	7	5.5	19.5	1	1	5.5
100	11	120	25	32.5	70	8	28	34	3	5.5	6.5	95	84	34	50	7	5.5	19.5	1	1	5.5
150	11	170	25	32.5	70	8	28	34	3	5.5	6.5	95	84	34	50	7	5.5	19.5	1	1	5.5
200	11	230	30	38	83	11	38	34	5	6.5	6.5	113	97	39.5	50	7	5.5	24.5	1	1	5.5
225	11	255	30	38	83	11	38	34	5	6.5	6.5	113	97	39.5	50	7	5.5	24.5	1	1	5.5
250	11	275	30	38	83	11	38	34	5	6.5	6.5	113	97	39.5	50	7	5.5	24.5	1	1	5.5
300	12	340	40	51	90	12	42	36	6	7	7	130	130	53	55	7.5	6	34	1	1	6
350	16	435	75	75	120	16	56	48	8	10	10	158	135	78	72	10	8	67	2	2	8
400	16	480	75	75	120	16	56	48	8	10	10	158	135	78	72	10	8	67	2	2	8
450	16	525	75	75	120	16	56	48	8	10	10	158	135	78	72	10	8	67	2	2	8
500	16	570	75	75	120	16	56	48	8	10	10	158	135	78	72	10	8	67	2	2	8
600	20	675	85	85	150	20	70	60	10	12	12	193	153	88.5	90	12	10	75	2	2	10
700	20	765	85	85	150	20	70	60	10	12	12	193	153	88.5	90	12	10	75	2	2	10
800	20	875	95	95	150	20	70	60	10	12	12	197	171	98.5	90	12	10	85	2	2	10
900	20	970	100	100	150	20	70	60	10	12	12	200	180	103.5	90	12	10	90	2	2	10

Table :-4

Table 4(Concluded)

- 1 Corners to be rounded off
- 2 The dimensions DS2, DS3, LSP, TS, T.H.S.HT and K shall conform to the values given in this table as there are critical dimensions. Other dimensions are for guidance only. The following tolerance shall apply on the critical dimensions.

Dimensions	Tolerances
T and HT	Same as that of barrel wall thickness given in 2.7.2
	Half the tolerance on barrel wall thickness given in 2.7.2

DS2, DS3,
LSP, K & S

The tolerance, in mm, shall be given below :

Chord Diameter	DS2	DS3	LSP	K	S
11	± 2	± 3	± 4	± 1.25	± 0.75
12	± 2	± 3	± 4	± 1.25	± 0.75
16	± 2.5	± 3.5	± 5	± 2.00	± 1.25
20	± 3	± 4	± 5.5	± 2.25	± 1.50
25	± 4	± 5	± 7	± 3.25	± 2

Table 5 Spigot and Socket Dimensions of NP3 and NP4 Class Pipes from 1000 to 2600 mm Diameter (Rubber Ring Confined Joint)
(Clauses 5.3 and 7.2)

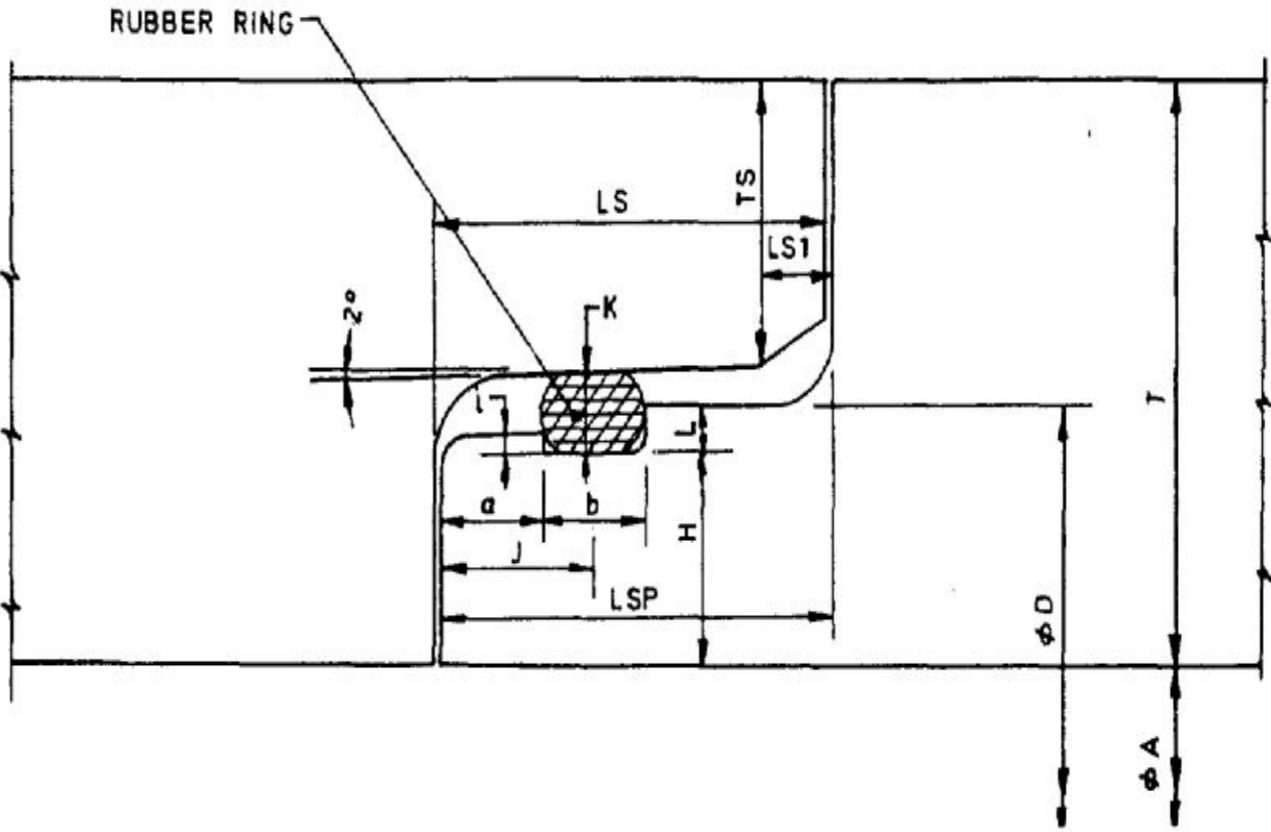

All dimension in millimeters.

Pipe Diameter A	Rubber Ring Chord Diameter	Rubber Ring Internal Diameter	T	TS	LS	LS1	K	LSP	a	b	J	H	I	L	\emptyset^D
(1)	(2)	(3)	(4)	(5)	(6)	(7)	(8)	(9)	(10)	(11)	(12)	(13)	(14)	(15)	(16)
1000	20	920	115	58.0	114	20	13	114	25	28	39	42	4	9	1102
1100	20	1003	115	58.0	114	20	13	114	25	28	39	42	4	9	1202
1200	20	1095	120	60.5	114	20	13	114	25	28	39	44.5	4	9	1307
1400	25	1275	135	67.5	114	20	16	114	25	35	42.5	50	4	10	1520
1600	25	1445	140	72.5	114	25	16	114	25	35	42.5	50	4	10	1720
1800	25	1620	150	77.5	114	25	16	114	25	35	42.5	55	4	10	1930
2000	25	1810	170	87.5	114	25	16	114	25	35	42.5	55	4	10	2150
2200	25	1995	185	95.0	114	25	16	114	25	35	42.5	72.5	4	10	2365
2400	25	2180	200	102.5	114	25	16	114	25	35	42.5	80	4	10	2580
2600	25	2360	215	110.0	114	25	16	114	25	35	42.5	87.5	4	10	2795

Table-5

Table 5 (Concluded)

NOTES

1 Corners to be rounded off.

2 The dimensions LS, LSP, TS, T, H, L, b and K shall conform to the values given in this table as these are critical dimensions. Other dimensions are for guidance only. The following tolerances shall apply on the critical dimension.

Dimension	Tolerances
LS and LSP	$\pm 7\text{mm}$.
T	Same as that of barrel wall thickness given in 2.7.2
H and TS	Half the tolerance on barrel wall thickness given in 2.7.2
L	$\pm 0.5\text{ mm}$.
b	$\pm 1\text{mm}$. for 20mm. rubber ring chord diameter
K	$\pm 2.5\text{mm}$. for 25mm. rubber ring chord diameter

Table 6 Spigot and Socket Dimensions for NP3 Reinforced and Unreinforced + NP4 Reinforced Pipes Made by Vertical Vibrated Casting Process from 300 to 2400 mm Diameter

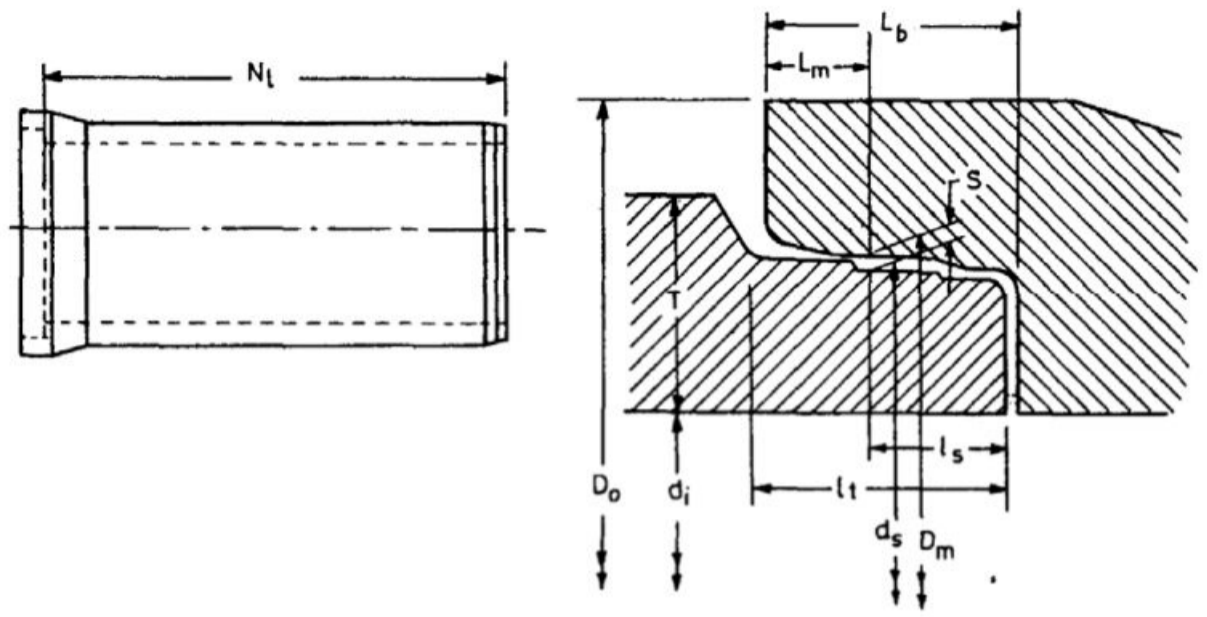

All dimensions in millimeter

di	G	R	T	D _o	L _t	L _b	d _s	D _m	L _m	I _s	S
300 ± 4	13	322	50	487 ± 4	112±4	105±2	370.07	386.07	49	50	8.00±1.0
350 ± 5	13	370	55	555 ± 4	112±4	105±2	425.07	441.07	49	50	8.00±1.0
400 ± 5	13	417	60	615 ± 4	112±4	105±2	480.07	496.07	49	50	8.00±1.0
450 ± 5	13	465	65	680 ± 4	112±4	105±2	536.07	552.07	49	50	8.00±1.0
500 ± 5	13	513	70	735 ± 4	112±4	105±2	590.07	606.07	49	50	8.00±1.0
600 ± 5	13	609	75	850 ± 4	112±4	105±2	700.07	716.07	49	50	8.00±1.0
700 ± 7	18	706	85	980 ± 5	141±5	132±3	808.00	830.00	61	65	11.00±1.2
800 ± 7	18	803	95	1100±5	141±5	132±3	924.00	946.00	61	65	11.00±1.2
900 ± 7	18	901	100	1215±5	141±5	132±3	1036.00	1058.00	61	65	11.00±1.2
1000 ± 7	18	998	115	1330±5	141±5	132±3	1148.00	1170.00	61	65	11.00±1.2
1100 ± 7	24	1097	120	1520±6	155±6	145±3	1262.00	1291.30	72	63	14.65±1.5
1200 ± 7	24	1195	125	1640±6	155±6	145±3	1372.48	1401.78	72	63	14.65±1.5
1400±10	24	1383	140	1870±6	155±6	145±3	1590.91	1620.21	72	63	14.65±1.5
1600±10	24	1578	165	2100±6	155±6	145±3	1814.91	1844.21	72	63	14.65±1.5
1800±10	24	1774	180	2340±6	155±6	145±3	2040.00	2069.30	72	63	14.65±1.5
2000±12	28	1850	190	2380±8	173±8	168±4	2126.80	2161.00	75	78	17.10±1.8
2200±12	28	2037	210	2620±8	173±8	168±4	2341.80	2376.00	75	78	17.10±1.8
2400±12	28	2224	225	2850±8	173±8	168±4	2556.80	2591.00	75	78	17.10±1.8

NOTES

1. G is the diameter of the unstretched rubber chord, hardness 40 + 5 IRHD, stretching 15 percent.
2. R is the inner diameter of the unstretched rubber ring.
3. T is the minimum barrel wall thickness.
4. d_x D_m L_m and L_s are nominal diameter

Table 7 Weight of Spirals (Hard Drawn Steel) in Socket of R/R Joint RCC Pipes of Different Classes (kg/Number)

(Clause 2.5.3)

Internal Diameter of Pipes mm	NP2 Class	NP3 Class	NP4 Class	P1 Class	P2 Class	P3 Class
(1)	(2)	(3)	(4)	(5)	(6)	(7)
80	0.08	0.08	0.08	0.08	0.08	0.08
100	0.09	0.09	0.09	0.09	0.09	0.09
150	0.12	0.12	0.12	0.12	0.12	0.15
200	0.14	0.14	0.21	0.14	0.21	0.35
225	0.15	0.15	0.26	0.15	0.26	0.43
250	0.16	0.16	0.31	0.16	0.31	0.51
300	0.45	0.45	0.53	0.45	0.53	0.84
350	0.51	0.64	0.64	0.51	0.74	1.24
400	0.56	0.71	0.71	0.56	0.99	1.66
450	0.63	0.76	0.76	0.63	1.23	2.26
500	0.68	0.87	1.08	0.68	1.57	2.85
600	0.81	1.00	2.12	1.52	2.88	4.74
700	0.92	2.16	3.02	1.79	3.96	6.79
800	1.14	2.87	4.67	2.04	6.28	9.99
900	1.50	4.06	6.03	2.63	8.29	-
1000	1.91	-	-	3.33	11.29	-
1100	2.34	-	-	4.08	-	-
1200	2.80	-	-	4.90	-	-
1400	3.82	-	-	-	-	-
1600	5.64	-	-	-	-	-
1800	7.25	-	-	-	-	-
2000	11.68	-	-	-	-	-
2200	12.88	-	-	-	-	-

NOTES

1. Longitudinal reinforcement shall be proportional to the length of socket cage as given in Table 1 & 2.
2. If mild steel is used for spiral reinforcement, the weight specified above shall be increased to 140/125.

Table 8 Design Requirements of Reinforced Concrete
Collars for Pipes of Class NP3 and NP4
(Clauses 2.5.3 and 2.7.1)

Nominal Internal Diameter of Pipe	Collar Dimensions			Reinforcements		
	Minimum Caulking Space	Minimum Thickness	Minimum Length	Longitudinal, Mild Steel or Hard Drawn Steel		Spiral Hard-Drawn Steel
mm (1)	mm (2)	mm (3)	mm (4)	Nos. (5)	kg/collar (6)	kg/collar (7)
90	13	25	150	6	0.08	0.07
100	13	25	150	6	0.08	0.08
150	13	25	150	6	0.08	0.10
200	13	25	150	6	0.08	0.12
225	13	25	150	6	0.08	0.14
250	13	25	150	6	0.08	0.16
300	16	30	150	8	0.11	0.22
350	19	35	200	8	0.15	0.40
400	19	35	200	8	0.15	0.50
450	19	35	200	8	0.15	0.60
500	19	40	200	8	0.15	0.70
600	19	40	200	8	0.23	1.05
700	19	45	200	8	0.23	1.85
800	19	50	200	8	0.23	2.05
900	19	55	200	8	0.33	2.25
1000	19	60	200	8	0.33	3.09
1100	19	65	200	8	0.33	4.11
1200	19	75	200	12	0.50	5.08
1400	19	80	200	12 or 8+8	0.67	6.55
1600	19	90	200	12 or 8+8	0.67	9.00
1800	19	100	200	12+12	1.00	12.15
2000	19	110	200	12+12	1.00	13.30

2.9 TESTING OF RCC NP3 PIPE

All the specifications mentioned in the I.S Code 3597-1998 & its latest revised addition shall be strictly followed.

SCOPE

- 2.9 This Standard covers methods for carrying out the following tests on concrete pipes, both reinforced concrete and prestressed concrete and of pressure and non pressure types to evaluate the properties stipulated in the relevant Indian Standards:

- a) Three-edge bearing test,
- b) Absorption test,
- c) Hydrostatic test,
- d) Permeability test, and
- e) Straightness test.

2.10 INSPECTION

2.10.1 The quality of all materials, process of manufacture and the finished pipes shall be subject to inspection and approval by the purchaser. If the pipe is tested for three-edge bearing or absorption, inspection of the reinforcement shall be made on the pipe sections used for those tests

2.10.2 The pipes shall be inspected by Third Party Inspection Agency, the cost of which is to be borne by contractor. The inspection of material while loading at factory and unloading at site also included in scope of this T.P.I. agency. The Third Party Inspection Agency will be from any Government undertaking agency like RITES, EIL, CEIL, MACON, WAPCOS, SGS etc approved by Gujarat Water Supply & Sewerage Board..

2.10.3

2.11 GENERAL PRECAUTION

2.11.1 The test specimens shall not have been exposed to a temperature below 4° C for 24 hours immediately preceding the test and shall be free from all visible moisture. The specimens shall be inspected and any specimen with visible flaws shall be discarded

2.11.2 If any test specimen fails because of mechanical reasons, such as failure of testing equipment or improper specimen preparation, it shall be discarded and another specimen taken.

2.12 SELECTION OF TEST SPECIMENS

In addition to the requirements specified in this standard, the number of test specimens and the method of their selection shall be in accordance with the specification for type of pipe being tested.

2.13 THREE-EDGE BEARING TEST

2.13.1 GENERAL

Three-edge bearing test shall be performed by the method given in 2.13.2. The pipe shall be surface dry when tested. The test specimen shall be tested in a machine so designed that a crushing force may be exerted in a true vertical plane through one diameter and extending the full length of the pipe but excluding the sockets, if any.

2.13.2. Three-Edge Bearing Method

2.13.2.1 Apparatus

2.13.2.2 Testing machine

Any mechanical or hand-powered device may be used in which the head that applies the load moves at such a speed as to increase

the load at a uniform rate of approximately 20 percent of the expected crushing load per linear meter per minute. The loading device shall be calibrated within an accuracy of ± 2 percent. The testing machine used for the load tests should produce a uniform deflection throughout, that the distribution of the test load along the length of the barrel of the pipe will not be appreciably affected by the deformation or yielding of any part of the machine during the application of the load.

2.13.2.3 Lower bearing block

The lower bearing block (see Fig 1) shall consist of two hardwood or hard rubber strips fastened to a wooden or steel beam or direct to a concrete base, which shall provide sufficient rigidity to permit application of maximum load without appreciable deflection. Wooden or rubber strips shall be straight, have a cross-section of not less than 50mm in width and not less than 25mm nor more than 40mm in height and shall have the top inside corners rounded to a radius of approximately 15mm. The interior vertical sides of the strips shall be parallel and spaced apart a distance of not more than $1/12^{\text{th}}$ of the specimen diameter but in no case less than 25mm. The bearing faces of the bottom strips shall not vary from a straight line vertically or horizontally by more than 1mm in 375 mm of the length under load.

About 6 mm thick hard rubber or felt should be placed/fixed at the lower face of the upper wooden block which shall come in contact with the surface of the pipe.

2.13.2.4 Upper bearing block

The upper bearing shall be a rigid hardwood block or a block with hard rubber facing at least 150 mm x 150 mm in cross-section. The wood block shall be free of knots and shall be straight and true from end to end. It shall be fastened to a steel or wood faced steel beam of such dimensions that deflection under maximum load will not be appreciable. The bearing face of the upper bearing block shall not deviate from a straight line by more than 1 mm in 375 mm of length under load.

2.13.2.5 The equipment shall be so designated that the load will be distributed about the center of the overall length of the pipe (see Fig. 1). The load may be applied either at a single point or at multiple points dependent on the length of the pipe being tested and the rigidity of the test frame.

NOTE- Multiple points of load applicable to the top bearing will permit use of lighter beams without appreciable deflection.

2.13.2.6 Crack measuring gauge

The crack measuring gauge shall be made from 0.25 mm thick strip and shall be of a shape as shown in fig 2.

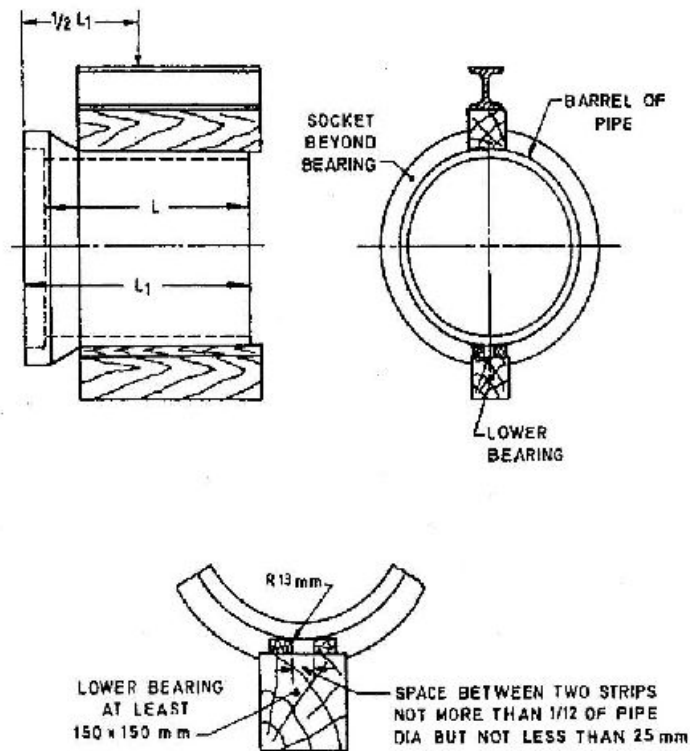

ENLARGED DETAIL OF LOWER BEARING

FIG. 1 THREE-EDGE BEARING METHOD

2.13.3 Procedure

- 2.13.3.1 The specimen shall be placed on the two bottom bearing strips in such a manner that the pipe tests firmly and with the most uniform possible bearing on each strip for the full length of the pipes less the socket portion, if any,

If mutually agreed upon by the manufacturer and the purchaser prior to the test, a fillet of plaster of Paris not exceeding 25 mm in thickness may be cast on the surface of the upper and lower bearing before the pipe is placed. The width of the fillet cap, top or bottom, shall be not more than 25mm per 300mm diameter, but in no case less than 25 mm.

- 2.13.3.2 Each end of the pipe at a point mid-way between the lower bearing strips shall be marked and then diametrically opposite points thereof shall be established. The top bearing block shall be so placed that it contacts the two ends of the pipe at this marks. After placing the specimen in the machine on the bottom strips, the top bearing shall be symmetrically aligned in the testing machine. Load shall be applied at the rate indicated in 2.13.2.2. Until either the formation of 0.25 mm wide crack or ultimate strength load, as may be specified, has been reached.

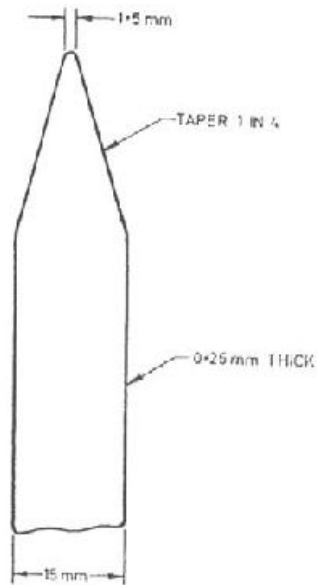

FIG. 2 GAUGE LEAP FOR MEASURING CRACKS

If both the 0.25 mm crack and ultimate load are required, the specified rate of loading need not be maintained after the load at 0.25 mm crack has been determined.

- 2.13.3.3 The 0.25 mm crack load is the maximum load applied to the pipe before a crack having a width of 0.25 mm measured at close intervals, occurs throughout a length of 300 mm or more. The crack shall be considered 0.25mm in width when the point of the measuring gauge described in 2.13.2.6 penetrates 1.5 mm at close intervals throughout the specified distance of 300 mm. The ultimate load will be reached when the pipe will sustain no greater load.

2.13.4 Calculation

The crushing strength in Newton per linear meter of pipe shall be calculated by dividing the total load on the specimen by the nominal laying length. Effective length of the pipe shall be taken as the nominal laying length of the specimen. In case of spigot and socket ended pipes, the effective length shall be equal to the overall length minus the depth of socket (see Fig 3) and in case of collar and flush jointed pipes, the effective length shall be equal to the overall length.

NOTE - In most machines the total load will include the dead weight of the top bearing plus the load applied by the loading apparatus.

2.14 ABSORPTION TEST

2.14.1 TEST SPECIMEN

Each specimen selected at random shall have a square area of $100 \text{ cm}^2 \pm 10$ percent of the length of the pipe as measured on surface of the pipe, and a thickness equal to the full depth of the pipe thickness and shall be free from visible cracks.

2.14.2 Procedure

2.14.2.1 Drying Specimens

Specimens shall be dried in a mechanical convection oven at a temperature of 105°C to 115°C until two successive weighings at intervals of not less than 8 h show an increment of loss not greater than 0.1 percent of the mass of the specimen. The drying time shall be not less than 36 h. The dry mass of the specimen shall be the mass after the final drying determined at ambient temperature.

2.14.2.2 After drying and weighing as specified in 2.14.2.1, the specimens shall be immersed in clean water at room temperature for the specified period. The specimens shall then be removed from the water and allowed to drain for not more than one minute. The superficial water shall then be removed by absorbent cloth or paper and the specimens weighted immediately.

2.14.2.3 The least count/accuracy of the weighing balance shall be 0.1 g which the test specimen shall be weighed.

2.14.2.4 Calculation and report

The increase in mass of the specimen over its dry mass shall be taken as the absorption of the specimen and shall be expressed as a percentage of the dry mass. The results shall be reported separately for each specimen.

2.15 HYDROSTATIC TEST

2.15.1 Test Specimen

The specimens for determination of leakage under interval hydrostatic pressure shall be sound and full size pipe. If the pipes are tested after storing in adverse weather condition presoaking shall be submerged in water or sprayed with water for a period not less than 6 hours prior to testing and excess water removed.

2.15.2 Procedure

2.15.2.1 The pipe shall be supported in such a way so that the longitudinal axis is approximately horizontal and the exterior surface excepting the supports can be examined readily.

2.15.2.2 The equipment for making the test shall be such that the specimen under test can be filled with water to the exclusion

of air and subjected to the required hydrostatic pressure. Apply hydrostatic pressure to the whole pipe including the portion of socket and rebated joints, that is, subjected to pressure in 'as laid' condition.

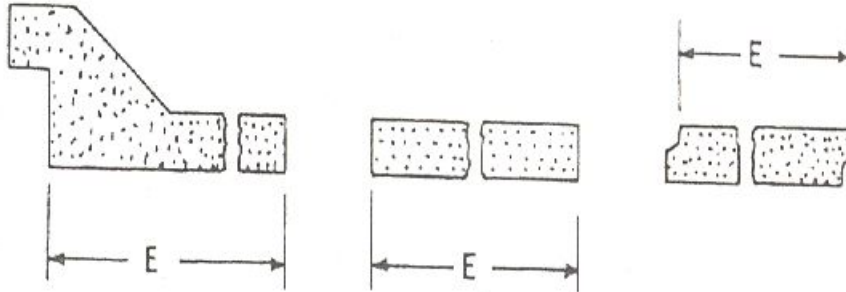

FIG. 3 ILLUSTRATING EFFECTIVE LENGTH 'E' OF PIPES

- 2.15.2.3 The specimen shall be filled with water and the air expelled. Pressure shall be applied at a gradual rate until the specified test pressure is reached, or beads of water on the pipe surface is seen, whichever occurs first.
- 2.15.2.4 Pressure shall be maintained for 1 min + 30 s for each 10mm of wall thickness (for precast concrete pipes wall thickness shall be full barrel wall thickness, whereas it shall be core thickness, in case of prestressed concrete pipe) or for twice that entire period if the application of pressure resulted in the formation of beads of water on the pipe surface.
- 2.15.2.5 At the end of the holding period, the pressure shall be released immediately if the test pressure has been maintained. If the beads of the water have not grown or run the pressure shall be increased slowly until the test pressure is reached or the beads of water grow or run (whichever occurs first).
- 2.15.2.6 If the test pressure has been reached without the beads of water growing or running, the test pressure shall be maintained constant for 1 min + 30 s for each 10 mm of wall thickness (for precast concrete pipes wall thickness shall be full barrel wall thickness, whereas it shall be core thickness, in case of prestressed concrete pipe). At the end of the holding period the pressure shall be released immediately.

After releasing the pressure, the test pipe shall be drained completely.

2.16 PERMEABILITY TEST

2.16.1 Prestressed Concrete pipes and Precast Concrete Pipes

This test shall be done on outside surface of the pipe. No additional treatment of any type shall be done on the pipe before permeability test is carried out. For Prestressed Concrete Pipe, the test shall be conducted at 3 places on coating and for Precast Concrete pipe at 2 places simultaneously, immediately after curing is completed (see Fig 4). In case this is done later, the pipe shall be kept wet for 48 hours prior to test. For plain/flush ended precast pipes, it shall be carried out about 300mm away from both ends.

2.16.1.1 Procedure

The dry surface of the pipe shall be scrapped by wire brush and loose particles, if any, removed. Sealant shall then be applied to the lower portion of the cup and cup shall be pressed on the pipe. After hardening of sealant, water shall be filled in cup with wash bottle. The glass tube with rubber cork shall then be fixed in the cup as shown in fig. Water in the tube shall then be filled using wash bottle and air shall be allowed to escape during filling. Precaution shall be taken, so that water does not leak either from cup ends or from the rubber stopper.

2.16.1.2 Initial Absorption

Water shall be filled up to zero mark and reading shall be taken at every half hour interval up to two hours. The drop in water level in the stand pipe at the end of two hours in the initial absorption.

2.16.1.3 Final Permeability

Fill the water in the stand pipe again up to zero mark and take the reading at one hour interval up to 4 h. The absorption in the fourth hour, that is, difference between fourth and third hour reading is the final permeability. The average of tests conducted at three places for prestressed Concrete pipe and two places for precast concrete pipe shall be expressed in cm^3 as final permeability.

Criteria for acceptance is the final permeability.

2.16 STRAIGHTNESS TEST

2.16.1 Procedure

2.16.1.1 A rigid straight edge, made into a gauge of the form and dimension shown in (fig 5) shall be placed in the bore of the pipe with edge x in contact with the pipe internal surface and/or the line parallel to the pipe axis. Hold the plane of the gauge in a radial plane.

2.16.2. If both ends of the gauge, when so placed are in contact with the internal surface of the pipe, the deviation from straightness is excessive. If this condition occurs at any one of four different position of the gauge, approximately equally spaced around the pipe circumference the pipe does not comply with the particular requirement.

2.16.3 If both ends of the gauge , when used as described in 2.16.1.1 are not in contact with the internal surface of the pipe at both ends, the gauge shall be reversed so that edge y, placed as in 2.16.1.1 is adjusted to the internal surface of the pipe. If the two studs in edge y cannot be made to touch the surface of the pipe simultaneously, The deviation from the straightness is excessive.

If this condition occur at any four position of the gauge the pipe does not conform with this particular requirement.

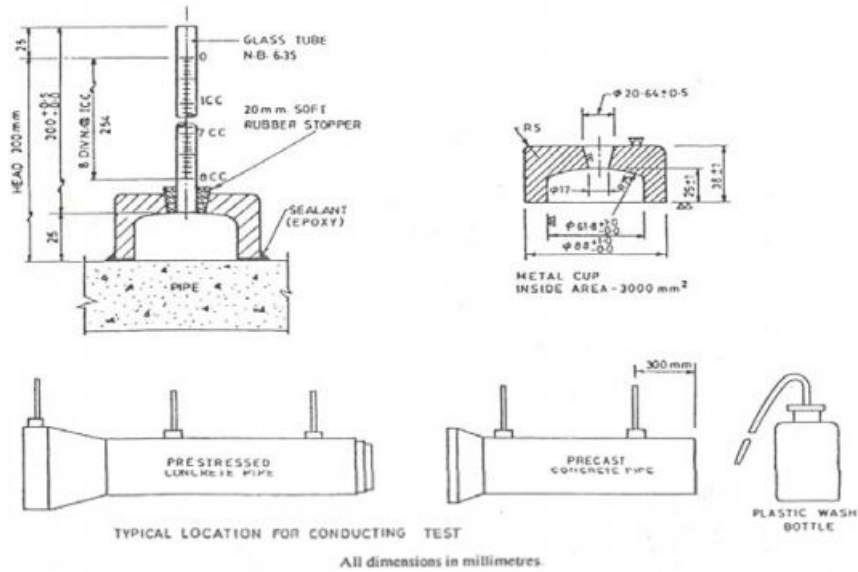

FIG. 4 METHOD FOR PERMEABILITY TESTING OF CONCRETE PIPES

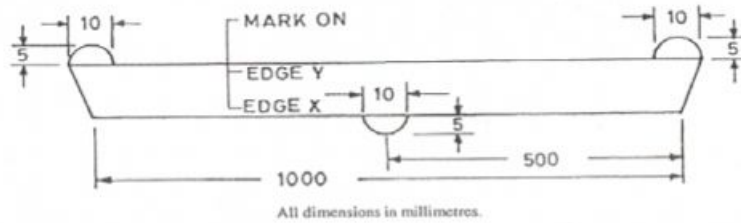

FIG. 5 STRAIGHTNESS TEST

3 PROVIDING & SUPPLYING RCC PRE-CAST M.H. FRAME & COVER & HOUSE CONNECTION CHAMBER FRAME AND COVER.

i) GENERAL :- The R.C.C. pre-cast manhole cover shall confirm to IS – 12592 / 2002 or its latest version and as per detailed Drawing attached herewith.

ii) SHAPES & DIMENSIONS :-

Shapes :- The shapes of pre-cast M.H. covers shall be circular only and 10 and 20 MT capacity for MHS and 5MT for HC chambers.

ii.a) DIMENSION & TOLERANCES: - length, breadth & diameter of pre-cast concrete manhole covers shall be such that the maximum clearance at top between the frame & the cover shall be 5mm. The minimum thickness of HD, MD & LD Covers shall be 90, 70 & 60 mm respectively.

ii.a.i) GRADES AND TYPES:

Manhole covers and frames shall be of the following four grades and types:

Grade	Grade Designation	Type/ Shape of Cover
Light Duty	LD-5	Rectangular, Square, Circular
Medium Duty	MD-10	Rectangular, Circular
Heavy Duty	HD-20	Rectangular (Scrapper Manhole), Square, Circular Lamphole
Extra Heavy Duty	EHD-35	Rectangular (Scrapper Manhole), Square and Circular

ii.a.ii) Recommended locations for placement of different grades and types/ shapes of manhole covers and frames are as given in ii.a.ii.a to ii.a.ii.c.

ii.a.ii.a) LD-5 Rectangular, Square or Circular Types

Suitable for use within residential and institutional complexes / areas with pedestrian but occasional light motor vehicle traffic. These are also used for 'Inspection chambers'.

ii.a.ii.b) MD 10 Circular or Rectangular Types

Suitable for use in service lanes / roads, on pavements for use under medium duty vehicular traffic including for car parking areas.

ii.a.ii.c) HD-20 Circular, Lamphole, Square or Rectangular (Scrapper Manhole) Types.

Suitable for use in institutional / commercial areas / carriageways / city trunk roads/ bus terminals with heavy duty vehicular traffic of wheel load between 50 to 100 kN, like buses, trucks and parking areas and where the manhole chambers are located in between the pavement and the middle of the road.

- iii) **SAMPLE:-** The contractor shall get approved sample of R.C.C. pre-cast M.H. Cover & frame & house connection chamber frame and covers and shall supply materials as per approved samples from approved factory.
- iv) **TESTS:-** The contractor / manufacturer at his own cost shall give all the required tests of RCC manhole cover and frame and all the testing facilities shall be kept open for the officers of RMC / Engineer-In-Charge at his factory.
- v) **RESPONSIBILITY:-** The contractor shall be responsible for the materials for a period of defect liability period. After payment of final bill of the work and during this period he will be responsible for defects in the materials & for road accidents due to defective M.H. / H.C.C. Frame & covers. He shall have to replace defective materials during this period at his cost.
- vi) **LETTER OF COMMITMENT:-** Contractor shall have to provide the letter of commitment in favour of Rajkot Municipal Corporation from the standard manufacturer of RCC Pre-cast M.H. / H.C.C. frame and covers to supply the desired quantity given in the e-Tender document in time (i.e. well in advance not to remain any manhole or chamber open at site of work after construction) with all quality control. Manufacturer shall have a long experience for preparing the RCC Pre-cast M.H. / H.C.C. frame and covers of all types i.e. HD, MD and LD as per the relevant I.S. Code of practice. A supply Schedule shall be submitted immediately on receipt of Work Order.
- vii) **R.C.C. MANHOLE COVERS AND FRAMES, FOLLOWING POINTS SHOULD BE CONSIDERED**

Sr.	Particulars	Heavy duty manhole covers and frames	Medium duty manhole covers and frames	Light duty manhole covers and frames
1	Clear opening of the manhole	500 mm dia.	500 mm dia.	500 mm dia.
2	Type of the covers & frames	Circular	Circular	Circular

The Rate shall be paid per Number basis / pair basis.

MATERIAL:

3.1. Cement

Cement used for the manufacture of precast concrete manhole covers shall conform to IS:269 or IS:455 or IS:1489 (Part-1) or IS:1489 (Part-2) or IS:6909 or IS:8041 or IS:8043 or IS:8112 or IS:12330 or IS:12269.

3.2. Aggregates

The aggregates used shall be well graded. The nominal maximum size of coarse aggregate shall not exceed 20 mm. The aggregates

shall be clean and free from deleterious matter and shall conform to the requirements of IS: 383.

3.3 Concrete

The mix proportions of concrete shall be determined by the manufacturer and shall be such as will produce a dense concrete without voids, honey combs, etc (See IS:456). The minimum cement content in the concrete shall be 360 kg/m^3 , with a maximum water cement ratio of 0.45. Concrete weaker than grade M30 shall not be used. Compaction of concrete shall be done by machine vibration.

3.4 Reinforcement

The reinforcement steel shall conform to Grade A of IS 2062 or IS 432 (Part-1) or IS 432 (Part-2) or IS 1786.

- 3.4.1 Reinforcement shall be clean and free from loose mill scale, loose rust, mud, oil, grease or any other coating which may reduce or destroy the bond between concrete and steel. A slight film of rust may not be regarded as harmful but steel shall not be visibly pitted by rust.

3.5 Steel Fibers

The diameter / equivalent diameter of steel fibres where used, shall not be greater than 0.75 mm. The aspect ratio of the fibers (ratio of the length of the fibre to its diameter / equivalent diameter) shall be in the range of 50 to 80. The minimum volume of fibres shall be 0.5 percent of the volume of concrete.

In case of propriety fibres, manufacturer's recommendations shall be taken into account.

3.6 Admixtures

Where admixtures are used, they shall conform to IS 9103.

3.7 Water

The water used shall be free from matter harmful to concrete or reinforcement or matter likely to cause efflorescence in the units and shall conform to the requirements of IS 456.

3.8 SHAPES AND DIMENSIONS

3.8.1 Shapes

The pre-cast concrete manhole covers and frames shall be of any shape given in (ii.a.i)

3.8.2 Dimensions And Tolerances

The dimensions and tolerances on dimensions of frames shall be as shown in Table-1 but outside dimensions of cover at top shall match with the corresponding frame so that the maximum clearance at bottom between the frame and the cover all round the periphery is not more than 5 mm and the top surface of the frame and cover is in level within a tolerance of ± 5 mm.

For facility of removing the cover from the frame, suitable taper matching with taper given for the frame shall be provided to the periphery of the cover (See Fig.1).

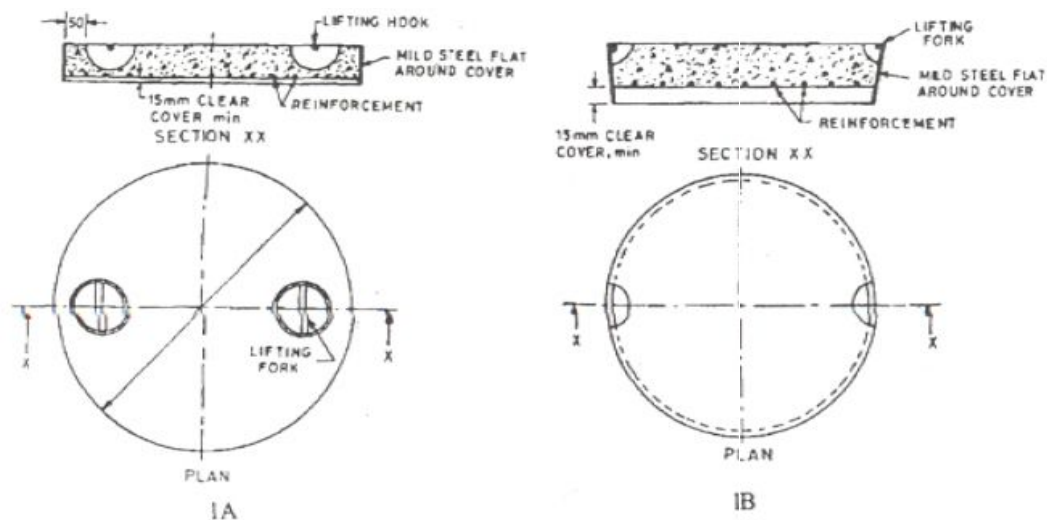

Fig.1 - Typical Illustration of Circular Precast Concrete Manhole Cover
All dimensions in millimeters

3.9 DESIGN:

The reinforced concrete manhole cover and frame shall be designed in accordance with the provisions of IS 456. If required by the purchaser, the manufacturer shall furnish the specification and drawings principle given in IS 456 may be followed.

3.10 MANUFACTURER

3.10.1 Mixing

Concrete shall be mixed in a mechanical mixer. Mixing shall be continued until there is a uniform distribution of the materials and the mass is uniform in colour and consistency. If steel fibres are used in addition to reinforcement, its shall be conformed to requirements given in 3.5.

3.10.2 Placing and Compaction

The reinforcement shall be placed in proper position in an appropriate mould coated with a thin layer of mould oil in case of frames and within the protective sheet (See 3.12.1.) in case of covers. Concrete shall be filled to slightly overfill and compacted by vibration and struck off level with a trowel.

Table-1 - Dimensions of Frame
(Clause 3.8.2)
All dimensions in millimeters

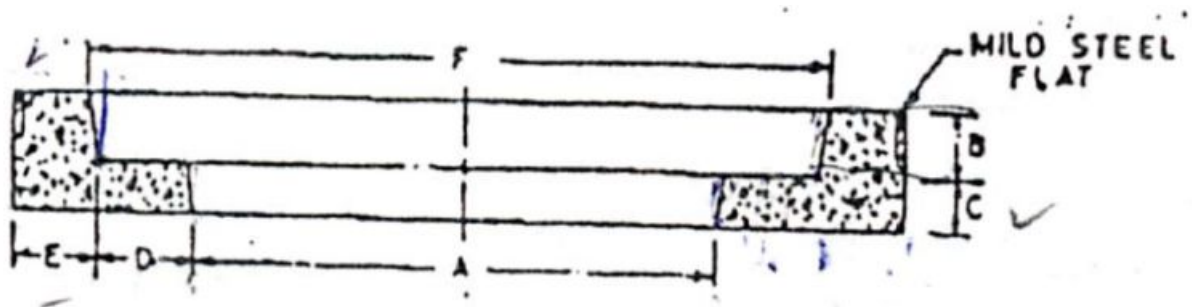

Grade Designation 1	Description 2	Clear Opening in Frame 3	B 4	C 5	D 6	E 7	F 8
LD-5	Light Duty Rectangular	450 x 450	60	50	50	50	566
LD-5	Light Duty Square	450 x 450 400 x 400	50 50	50 50	50 50	50 50	566 x 566 516 x 516
LD-5	Light Duty Circular	370 560 500 450	50 50 50 50	50 50 50 50	50 50 50 50	50 50 50 50	486 676 616 566
MD-10	Medium Duty Rectangular	450 x 600	70	50	50	50	570 x 720
MD-10	Medium Duty Circular	450 500 560 600	70 70 70 70	50 50 50 50	50 50 50 50	50 50 50 50	570 620 680 720
HD-20	Heavy Duty Rectangular (Scrapper)	900 x 450	100	75	75	75	1080x 630
HD-20	Heavy Duty Square	560 x 560	100	75	75	75	740 x 740
HD-20	Heavy Duty Circular	450 500 560 600	90 90 90 90	75 75 75 75	75 75 75 75	75 75 75 75	630 680 740 780
HD-20	Heavy Duty Lamphole	350	100	75	75	75	530
EHD-35	Extra Heavy Duty Rectangular	900 x 560	100	75	75	75	1078x 738

EHD-35	Extra Heavy Duty Square	560 x 560	100	75	75	75	738 x 738
EHD-35	Extra Heavy Duty Circular	450	100	75	75	75	628
		500	100	75	75	75	678
		560	100	75	75	75	738
		600	100	75	75	75	778

NOTES:

1. Tolerance on C shall be ± 5 mm, tolerance on A, B, D and E shall be
+5mm
0 mm
2. For facility of removing the manhole cover suitable upward taper not more than 5° may be provided to the inner periphery of the frame.
3. If required for the removal of the moulds suitable taper not more than 5° can be given at the lower inner periphery of the frame (See figure).
 - 3.10.2.1 Use of needle vibrators for compacting the wet concrete mix containing fibres is not recommended since the holes left by the vibrator in the wet mix may not close after its removal owing to the interlocking of the fibres with the mix. Compaction by means of shutter or form or table vibrators is recommended. In case of extra heavy duty and heavy duty cover and frame, compaction by means of pressure-cum-vibration technique may also be employed so as to achieve dense and strong concrete.
 - 3.10.2.2 Clear cover to reinforcement shall be not less than 15 mm.
 - 3.10.2.3 After demoulding, cover and frame shall be protected until they are sufficiently hardened to permit handling without damage.
- 3.11 Curing
 - 3.11.1.1 The hardened concrete manhole cover and frame shall be placed in a curing water tank. The period of curing shall be as given in IS 456.
 - 3.11.1.2 Steam curing of manhole cover and frames may be adopted instead of method specified in 3.11.1.1 followed by normal curing for 7 days provided the requirements of pressure or non-pressure steam curing are fulfilled and the manhole cover and frames meet the requirements specified in this standard.
- 3.12 Edge Protection and Finishing
 - 3.12.1 Cover

To prevent any possible damage from corrosion of reinforcing steel, the underside of the covers shall be treated with anticorrosive paint. The top surface of the covers shall be given a chequered finish.

In order to protect the edges of the covers from possible damage at the time of lifting and handling, it is necessary that the manhole covers shall be cast with a protective mild steel sheet of minimum 2 mm thickness around the periphery of the covers. Exposed surface of mild steel sheet shall be given suitable treatment with anti-corrosive paint or coating.

3.12.2 Suitable arrangement may be made for fixing the manhole cover and frame in position on the manholes by mutual agreement between the manufacturer and the purchaser.

3.12.3 The manufacture of manhole cover and frame shall be such as to ensure the compatibility of their seatings. For classes HD 20 and HD 35, these seatings shall be manufactured in such a way as to ensure stability and quietness in use. This may be achieved by grinding the contact surface, if needed.

3.13 LIFTING HOOKS:

The minimum diameter of mild steel rod used as lifting device shall be 12 mm for light and medium duty covers and 16 mm for heavy and extra heavy duty covers. The lifting device shall be protected from corrosion by hot dip galvanizing or any other suitable means approved by the purchaser or shall be made of naturally corrosion resistant metal rods.

The lifting arrangement shall be as agreed between the manufacturer and the purchaser. Typical arrangements of lifting devices are shown in Fig. 1A and 1B.

3.14 PHYSICAL REQUIREMENTS:

3.14.1 General

All the covers and frames shall be sound and free from cracks and other defects which interferes with the proper placing of the unit or impair the strength or performance of the units. Minor chippings resulting from the customary method of handling and transportation shall not be deemed ground for rejection

3.14.2 Dimensions

The dimensions of the cover and frame shall be as specified in 3.8; the overall dimensions of the units shall be measured in accordance with Annexure-B.

3.14.3 Load Test

The breaking load of individual units when tested in accordance with the method described in Annex-C shall be not less than the values specified in Table-2. Also, the permanent set shall not exceed the requirement given in Annexure-C.

Table-2 - Test Load and Diameter of Block
(Clause 3.14.3, 4.18.3 and C.1.1)

Grade of Cover	Type	Load kN	Diameter of Block mm
1	2	3	4
LD-5	Rectangular, Square or Circular	50	300
MD-10	Rectangular, or Circular	100	300
HD-20	Rectangular, Square or Circular	200	300
EHD-35	Rectangular, Square or Circular	350	300

3.15 TESTS

Tests shall be conducted on samples of covers and frames selected according to the sampling procedure given in 3.16, to ensure conformity with the physical requirements laid down in 3.14.

3.16 SAMPLING AND INSPECTION

3.16.1 Scale of Sampling

3.16.1.1 Lot

In any consignment, 500 precast concrete manhole covers and frames or a part thereof the same dimensions and belonging to the same batch of manufacture, shall be grouped together to constitute a lot.

3.16.1.2 For ascertaining the conformity of the materials in the lot to the requirements of this specification, samples shall be tested from each lot separately.

3.16.1.3 The number of covers and frames to be selected from the lot shall depend on the size of the lot and shall be according to Table-3

Table 3 - Scale of Sampling and Permissible
Number of Defectives
(Clause 3.16.1.3, 4.17.2. and 4.18.2)

No.of covers or frames in the lot.	Dimensional Requirements		Number of samples for load test on cover only
	Sample size	Acceptance Number	
1	2	3	4
Upto 100	10	1	2
101 to 200	15	1	3
201 to 300	20	2	4
301 to 500	30	3	5

Note:

If the number of covers in the lot is 20 or less, the number of samples for load test shall be decided by mutual agreement between the purchaser and the manufacturer.

- 3.16.1.4 The R.C.C. precast manhole frames & covers shall be inspected by Third Party Inspection Agency, the cost of which is to be borne by contractor. The Third Party Inspection Agency will be from any Government undertaking agency like RITES, EIL, CEIL, MACON, WAPCOS, SGS etc approved by Gujarat Water Supply & Sewerage Board.
- 3.16.2 Sampling Covers and Frames in Motion
Whenever practicable, samples of covers and frames shall be taken when the units are being moved as in the case of loading, unloading, etc. The batch from where the samples are to be drawn shall be divided into a number of convenient portions such that when one sample is drawn from each of these portions, the minimum number of units specified under 3.16.1.3, is provided.
- 3.16.3 Sampling Covers and Frames from a Stack
The number of covers and frames required for the test shall be taken at random from across the top of the stacks, the sides accessible and from the interior of the stacks by opening trenches from the top.
- 3.17 Number of Tests
- 3.17.1 All the covers and frames selected according to 3.16.1.3, shall be checked for dimensions (See 3.14.2) and inspected for visual defects (See 3.14.1).
- 3.17.2 The number of covers to be subjected to load test shall be according to col 4 of Table-3.
- 3.18 CRITERIA FOR CONFORMITY
- 3.18.1 The lot shall be considered as conforming to the requirements of the specification conditions mentioned in 4.18.2 and 4.18.3 are satisfied.
- 3.18.2 The number of covers and frames with dimensions outside the tolerance limit and / or with visual defects among those inspected shall be less than or equal to the corresponding acceptance number given in col 3 of Table-3.
- 3.18.3 For load test no value shall be less than the load specified in Table-2
- 3.19 MANUFACTURER'S CERTIFICATE
The manufacturer shall satisfy himself that the manhole cover and frame conform to the requirements of this specification, and if requested, shall supply a certificate to this effect to the purchaser or his representative.
- 3.20 MARKING
- 3.20.1 Following information shall be clearly and permanently marked on top of each manhole cover and frame.
- a) Identification of the source of manufacturer
 - b) Grade designation denoted by LD 2.5/ MD 10 / HD 20/ EHD 35 or 5T / 10T / 20T / 35T.
 - c) Any identification mark as required by the purchaser.

ANNEX-B
(Clause 3.14.2)
MEASUREMENT OF DIMENSIONS

B-1 PROCEDURE:

B-1.1 Individually measurements of the dimensions of each unit shall be made with a steel scale graduated in 1 mm divisions and shall be read to the nearest division of scale and the average recorded.

B-1.2 Length and diameter shall be measured on the longitudinal center line of each face, with of square or rectangular manhole covers across the top and bottom bearing at mid length and thickness on both faces at mid length.

B-2 REPORT

The report shall show the average length, width or diameter and thickness of each specimen.

ANNEX-C
(Clause 3.14.3)
METHOD FOR LOAD TEST

C-1 PROCEDURE:

C-1.1 A suitable testing arrangement is shown in Fig.2. The cover shall be supported in a frame which may be standard frame or a specially made testing appliance simulating normal conditions of use. The specified load as given in Table-2 shall be applied without shock through the medium of a bearing block faced with hard rubber or other resilient material. The bearing block shall be of the size specified in Table-2 and shall bear centrally on the cover. The block shall be sufficiently rigid to ensure that the load on the cover is uniformly distributed over the full area of the block.

Fig.2 Arrangement For Load Test of Manhole Cover

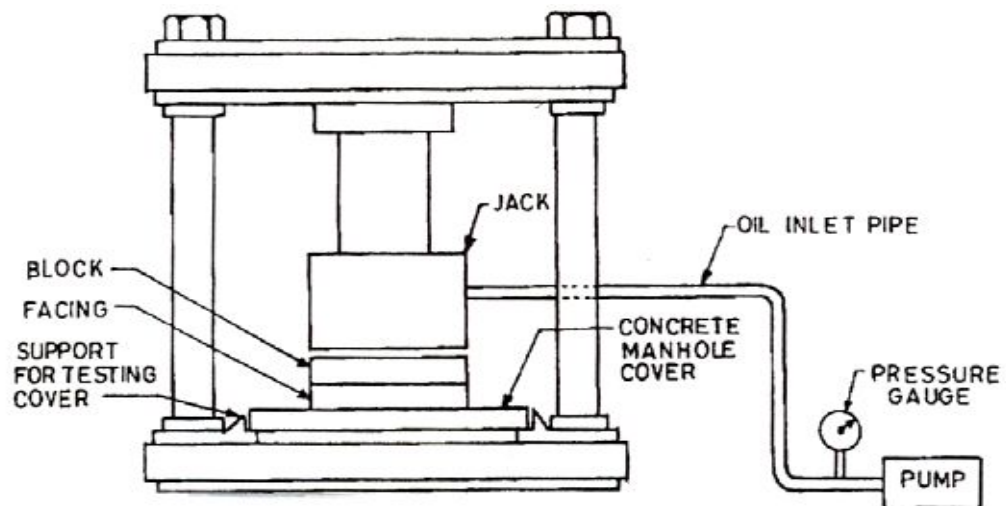

C-1.2 All covers shall be submitted to the following tests:

- a) Measurement of the permanent set of the cover after the application of 2/3 of the test load.
- b) Application of test load

C-1.2.1 Measurement of permanent Set of the Cover After the Application of 2/3 of the Test load.
Before the load is applied take an initial reading at the geometric center of the cover.

The load shall be applied at the rate of approximately 0.6 ± 0.4 N/mm/s up to 2/3 of the test load. The load on the test specimen is then released. This procedure shall be carried out five times. Then take reading at the geometric center.

The permanent set shall then be determined on the difference of the measured readings before the first and the fifth loading. The permanent set shall not exceed 1/100 times the diameter of the largest circle that can be inscribed in the clear area of the frame as shown in Fig.3.

C-1.2.2 Application of the Test Load.

Immediately after the test according to C-1.2.1, the test load shall be applied at the same rate given in C-1.2.1., the test load shall be applied until it is achieved. The test load to be maintained for 30 ± 2 s. Cover shall not show cracks in the course of the test.

Fig.3 Illustration of Largest Incribed Circle in Clear Area

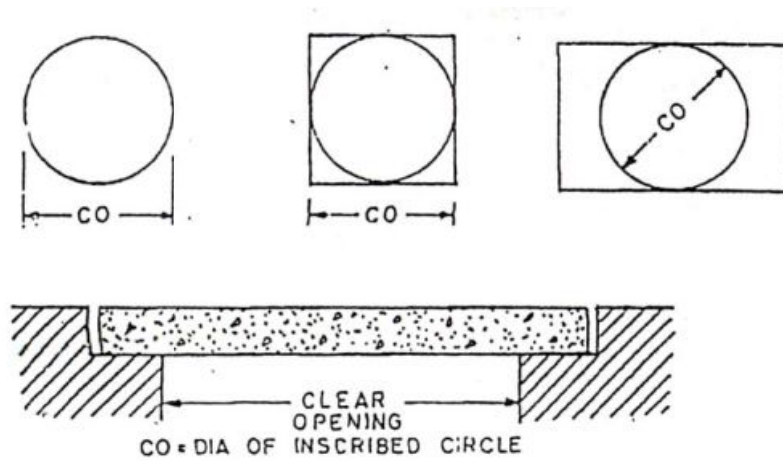

- 4 Providing supplying & fixing M.S. Frame and RCC Precleeper Beam & Sleeper Covers for Scrapper Manhole as per given type design and specifications:-

M.S. Frame and RCC Precast Beam & Covers for Scrapper Manhole shall be manufactured as per given type design shown in drawing No.16. The RCC Precast Beam & Covers shall be casted in M-25 on vibrating platform.

The size of M.S. Frame and RCC Precast Sleeper Beam & Sleeper Covers shall be kept as under :-

- 1) M.S. Frame:- 1440 x 1120 mm (inside) by using 110 x 110 x 8 mm standard M.S. angle with braces for beam support and necessary hold fast with lead primer paint.
- 2) RCC Precast Sleeper Beam:- 1400 x 100 x 100 mm.
- 3) RCC Precast Sleeper Cover:- 1100 x 350 x 100 mm with 15x15x3 mm size M.S. angle at outer top periphery.

For each Scrapper Manhole one set comprises of (a) M.S. frame-1 no. (b) RCC Precast Sleeper Beam-1 no. & (c) Sleeper Cover-4 nos, shall be provided with supply and fixing.

The rate of Providing, Supplying & Fixing of M.S. Frame and RCC Precast Sleeper Beam & Sleeper Covers for Scrapper Manhole shall be paid per set.

B2 LABOUR SPECIFICATION

1	Excavation for sewer line trenches, manholes incl. All safety provisions using site rails etc. including refilling the trenches & stacking the excavated stuff including disposal of Excavated stuff in designated place as directed in all sorts of soil and soft murrum, hard murrum, boulders, and macadam road and soft rock and hard rock Average Rated Rate including removing surplus earth
1.1	up to 1.50 mt depth
1.2	1.50mt to 3.00 mt depth
1.3	3.00 mt to 4.50 depth

1. EXCAVATION AND REFILLING:

Excavation for sewer line trenches, manholes and house connection chambers etc. with shoring strutting bailing our water form trencher wherever necessary including excavation in khal kuvas or soak pits encountered in the work and making the good after the work and all safety measures and provisions such as site rails fencing lighting watching and stacking excavated stuff up to a lead of cleaning the site etc, as stipulated in the e-Tender specifications complete for lifts and soil strata as specified below :-

- (i) In all sorts of soil & soft murrum including macadam road, khal kuvas and soak pits.
- (ii) In hard murrum boulders.
- (iii) In soft rock, masonry structures like in C.M., L.M. or lime concrete.
- (iv) In hard rock, in C.C. 1:2:4 or R.C.C. with controlled blasting and or chiseling

No payment will be made for removal of excavated stuff from site and laying of excavated stuff as directed shall have to be carried out by the agency without any extra cost.

Excavation for sewer line trenches, manholes incl. All safety provisions using site rails etc. including refilling the trenches & stacking the excavated stuff including disposal of Excavated stuff in designated area as directed in all sorts of soil and soft murrum, hard murrum, boulders, and macadam road and soft rock and hard rock average rated rate including removing surplus earth. No extra payment will be made for removing of excavated stuff from site.

1.1 up to 1.50 mt depth

1.1.1. The item shall include dry or wet excavation and removal of excavated material and its stacking and disposal in a manner hereinafter specified. The water met with if any, shall be bailed or pumped out by the contractor as necessary. This Rate includes excavation of soil in soft murrum , hard murrum average rate. The payment of this item shall be per Cu.M.

1.1.2. The contractor shall provide all materials and perform all labour necessary for the excavation and completion of the work in accordance with the drawings and specifications and the intent thereof. This Rate includes excavation of rock in soft rock, hard rock average rate. The payment of this item shall be per Cu.M.

1.1.3. The Contractor shall provide necessary protection to labour materials, equipment etc. to ensure safety against risk and accident. The B.I.S.

standard in this regard shall be followed (IS 3764 – 1966)

- 1.1.4. The Contractor shall be liable to pay compensation for injury to life, and damage to property, if any, caused due to any operation connected with this item.
- 1.1.5. The Contractor shall hand over the site of work in neat and tidy condition after completion of work and shall remove all rubbish arising out of construction work.
- 1.1.6. The contractor shall carry out the work of trial hole of the sizes and depths and at places as directed by the Engineer-in-charge to accurately locate and determine the portions of services like water mains and drains, electric cables, telephone cables .etc, and shall fill them back as required and as ordered. The work shall be paid as per the item of excavation.

1.1.7 Widths of excavation for different diameter of pipes

The width of trenches for different diameters of pipes shall be paid as per actual excavation done AND as per Drawing (DRN/PHASE-II PART-II/DRG No.6 attached herewith) whichever is less.

1.1.8. Depth of Excavation of Trenches:

The depths of excavation for the trenches shall be calculated from the surface to the bottom of the foundation, No payment shall be made for any excavation, beyond the width and depth, as specified above.

1.1.9. A Grip to be cut for pipe collar :

Where a collar is to be provided or where socket of the pipe comes a grip shall be cut in the bottom of the trench or bedding as necessary below the bed of the pipes so that the pipe may have a fair bearing on its shaft and not rest upon its collars. Such grip shall be maintained clear until the joint has been passed by the Engineer – in - charge

1.1.10 Trenches in Rocky Ground:

The trenches in stony or rock ground shall be excavated all along to the full depth such that the bottom of the excavation shall not be higher at any point than the bottom of the concrete bedding layer below the sewer pipe.

1.1.11 Measurement of length of Excavation:

The length of excavation for trenches shall be measured in the horizontal plane between manholes.

The excavation shall be taken up at such places and in such lengths as shall be approved by the Engineer-in-charge. The excavation shall proceed in such portions at one time as the Engineer-in-charge may direct. No permanent works shall be started unless the Engineer-in-charge approves the excavations. The length of trench excavated ahead of the laying and the length of trench which may remain open at any time shall at all times be subject to the approval of the Engineer-in-charge. It shall be at no time, longer than can properly be protected from caving. In case of tapering in excavation, average width in measurement shall be taken in to

account.

The materials from the excavation shall be deposited on either side of the trench leaving a clear berm on each side at least 40cm wide or at such further distances from the edges of the trench, as may be necessary. To prevent the weight of materials from causing the side of the trench to slip or fall, or at such distance and in such a manner as to avoid covering fire-hydrants, sluice valves, gas siphons, manhole covers and the like and so as to avoid abutting any wall or structure or causing inconvenience to the public or other persons, or otherwise as the Engineer-in-charge may direct.

In case, where the Engineer-in-charge decides that the width of the road or lane, where the work of excavations to be carried out is so narrow as to warrant stacking of excavated materials away from the site of the work the contractor shall have to remove the same if so directed in designated area as directed. The excavated stuff shall be brought back for refilling the trenches when required. The surplus material shall be removed as directed. No claims for stacking the excavated stuff away from the site of work or bringing it back for refilling trenches shall be entertained.

1.1.12. Bottom of Trenches and foundation to be saturated with water

The bottom of all trenches and the foundations of all structure shall be saturated with water and well rammed wherever the Engineer may consider it necessary to do so.

1.1.13. Excess Excavation due to nature of sub-soil for additional foundation

If in any place, the Engineer-in-charge considers on account of the nature of sub soil additional foundations of concrete, rubble or other wise necessary or if at any place, for any purpose whatsoever he required the excavation to be carried out deeper than shown on the plans or described in the specifications, the same shall be carried out as may be ordered by the Engineer-in-charge and such additional works shall be measured and paid for to the contractors according to the rates. Excavation and necessary dewatering and shoring strutting for chambers, Main holes, Vent shafts etc, is also included in this item and no extra shall be paid for excavation for chambers manholes, Vent shafts etc.

1.1.14. Unauthorized excess excavation:

Where excavations are made in excess of the width and depth indicated on the drawings, either by error or by accident the hollows so formed shall be filled in with lime concrete or rubble masonry or otherwise as directed by the Engineer-in-charge to his full satisfaction at the expense of the contractor.

1.1.15. Fencing / Lighting and Watching:

The contractor shall make all proper provisions for protecting the work by fences and by watching and lighting at night, or otherwise as may be directed by the Engineer-in-charge. The posts of the fencing shall be of timber or of other approved material securely fixed in the ground not more that 3M apart. The timber posts shall not be less than 75mm in dia, and shall not be less than 1.2 M above the surface of the ground.

There shall be two rails one near the top of the posts and the other

about 150mm above the ground and shall be 50 mm to 70mm dia and sufficiently long to run from post to post to which they shall be securely fixed as per direction of the Engineer-in-charge. The method of projecting rails beyond the posts and tying them together where they meet will not be allowed on any account al along the edges of the excavated trenches a bank of earth about 1.20m high shall be formed where required by the Engineer-in-charge for additional protection Adequate number of red lights wherever required shall be provided at night. Also a watchman shall be engaged to see that the lights are properly maintained during night.

In the event of contractor not fully complying with the provisions of this clause, the Engineer may with or without notice to the contractor put up a fence, improve the lighting and adopt such other measures as he may deem necessary for the safety and all costs of such works including penalty as may be decided by the Engineer-in-charge shall be paid by the contractor the contractor shall also provide and display special Boards painted with fluorescent paints indicating the progress of the work along a particular road.

1.1.16 Maintenance of Water Pipes, Gas Pipes, Telephone lines, Electric lines and Drains Khalkuvas, Sewers during Excavation:

The contractor shall at the rates entered in the bill of quantities and rates, carry out all excavation as the Engineer-in-charge may require in order to locate the positions of water pipes, Gas Pipes, Telephone lines, Electric lines, drains, khalkuvas, sewers, or any other structures in connection with them and shall properly maintain and protect these services by means of shoring strutting planking over padding or otherwise as the Engineer-in-charge may direct during works resulting from the same shall be made good and effectively remedied by the contractor at his cost if the contractor fails to comply with the requirements, the Engineer-in-charge will got it repaired from any other agency at the expense of the contractor. If however, the Engineer-in-charge considers it impracticable for the contractor to maintain any such water pipes, drains, Khalkuvas, sewers or other works and that exigencies of the work necessitate the breaking down removal, or diversion of any such water pipes, drains, khalkuvas, sewers, or other work, then he may direct the contractor to break down or remove any of the above mentioned services and ask the contractor to provide such chutes pumps or other equipment of raising and temporary passage of the water or sewerage. The cost of pumping out or otherwise removing any water or sewerage which may escape from any such broken water pipes, drains, khalkuvas, sewers shall be borne by the contractor.

1.1.17. Shoring:

1.1.17.1 Wherever shoring is found necessary by the Engineer-in-charge the contractor shall provide the same in the best possible manner with the materials as required and as directed by the Engineer-in-charge to his complete satisfaction. The contractor shall employ such kind or kinds of shoring as the Engineer may consider the exigencies of

the work to require and it is to be distinctly understood that the word 'shoring' is to comprise all classes of such work and all appliances and appurtenances, including polling Corporations, sheet piling and runners (whether the joints be butt., groove and tongue, feather edge and grove, birds mouth and double splay, rebate or otherwise), together with walkways, strut, props point blank shores, raking shores, blocks, wedges, Iron dogs, bolts, screws, nails and everything that may be required for due execution of the work.

1.1.17.2 Contractors responsibility for secure shoring and / or all damages:

The contractor shall be responsible for providing secured shoring and for taking every other precaution which may be necessary or proper for protecting any building or any other structure from getting damaged by the excavation of any trench or otherwise by the execution of the works in the vicinity of such building of structure.

If the Engineer-in-charge shall require the adoption of any special or extra measures, or precautions, the contractor shall forthwith adopt and supply the same. However, this revision shall not in any degree relieve the contractor from his responsibility or from liability under the conditions of the contract in respect of any claim made against the Corporation for loss or damage which might be caused to any such building or structures by the execution of any works or otherwise.

After the work is completed near building, the contractor shall remove the shoring safety without slipping of soil of trenches if any and make good any cutting out or other damage that might have been done.

1.1.17.3 Liability of Timbering:

No work approved by the Engineer-in-charge or his representative about timbering shall absolve the contractor from his responsibility and he will be responsible for making good damage caused as about result of the failure of timbering to give proper support to the sides of the excavation.

The timbering to the sides of excavation for structures shall be carried out in such a way that there is no obstruction caused to the fixing of form work for the walls. The supporting struts and walling shall be removed by the contractor in stage to facilitate progress of concreting pipe laying etc.

If the Engineer-in-charge finds that the standard of timbering is not according to requirements or that the sides of the excavations have not been secured in a manner to render such excavations safe for working may be one hour after notifying the contractor of his representative in writing about this shall employ his own men to mend the timbering and the cost of such workmen and materials employed including penalty shall be paid by the contractor.

1.1.17.4 Removing shoring:

No part of the shoring shall nay time be removed by the contractor without obtaining permission of the Engineer-in-charge While out shoring planks, the hollows if any, formed shall simultaneously be filled in with soft earth well rammed with rammers after watering.

1.1.17.5 Shoring left in Trenches:

The Engineer-in-charge may order in writing portions of shoring to be left in the trenches at such places where it is found absolutely necessary to do so, so at to avoid any damage to buildings, cables, water mains, sewers, etc. in close proximity of the excavation.

The contractor shall not claim, anything, whatsoever for the shoring which might have been left in the trenches.

1.1.17.6 Steel trench sheeting:

Where the subsoil conditions meet with are of a soft and unstable in trench excavation the normal methods of timbering will not prove sufficient to avoid subsidence of the adjoining road surface and other services. In such circumstances, the contractor will be required to use steel trench sheeting or sheet steel pining adequately supported by timber struts, welling etc. without any extra cost. The contractor shall supply, and subsequently remove trench sheeting or piling where no longer required.

1.1.18. Constructing Temporary bunds & sumps:

For the purpose of keeping the excavations dry the work shall, if necessary he divided into sections or separate portions, to be determined by the Engineer-in-charge and temporary bunds shall be put up by the Contractor. Sump shall be excavated by the Contractor at such distances apart and of such depths, as the Engineer-in-charge may direct to allow the pumps to work. When and as the work progresses, other sumps shall be excavated by the Contractor from time to time. The sumps not in use shall be filled in by the Contractor to the satisfaction of the Engineer-in-charge. The contractor shall not claim anything extra for temporary bunds and sumps or their removal and refilling, nor shall such work be taken into measurements in any way.

1.1.19. Rate for Excavation:

The rates for excavation shall be included and cover without extra charge all the stipulations continued in every portion of these specifications, with regard to setting out, provision for the passage or traffic and for access to premises, arrangements for the continuance of drainage, khalkuvas or such points water supply or lighting (If interrupted by the works) arrangements, for the efficient protection of the life and property, fencing, lighting, watching,

shaping the trenches, maintenance of water pipes, gas pipes, telephone lines, electric lines drains, khalkuvas and other work met with in or about the excavation driving them dismantling them, rebuilding them as necessary, subsequent re-excavation, on account of rain, holiday or special occasion, filling necessary dewatering etc. complete.

- 1.1.20 The excavation shall be carried out in the strata met with as specified in the proper manner and with lifts mentioned therein.

Tender Item

1.2. **1.51mt to 3.00 mt depth.**

All the items of excavation for trenches and manholes vent shaft, house connections, chambers and connecting sewers as described under 1.1 above shall also apply here.

- 1.2.1 This Rate includes excavation of soil in soft murrum , hard murrum average rate. The payment of this item shall be per Cu.M.
- 1.2.2 This Rate includes excavation of soil in soft rock , hard rock average rate. The payment of this item shall be per Cu.M.

Tender Item

1.3 **3.01 mt to 4.50 depth**

All the items of excavation for trenches and manholes vent shaft, house connections, chambers and connecting sewers as described under 1.1 above shall also apply here.

- 1.3.1 This Rate includes excavation of soil in soft murrum , hard murrum average rate. The payment of this item shall be per Cu.M.
- 1.3.2 This Rate includes excavation of soil in soft rock , hard rock average rate. The payment of this item shall be per Cu.M.

Tender Item

1.4 **4.51 mt to 6.00 depth**

All the items of excavation for trenches and manholes vent shaft, house connections, chambers and connecting sewers as described under 1.1 above shall also apply here.

- 1.4.1 This Rate includes excavation of soil in soft murrum , hard murrum average rate. The payment of this item shall be per Cu.M.
- 1.4.2 This Rate includes excavation of soil in soft rock , hard rock average rate. The payment of this item shall be per Cu.M.

Tender Item

1.5 **6.01 mt to 7.50 depth**

All the items of excavation for trenches and manholes vent shaft, house connections, chambers and connecting sewers as described under 1.1 above shall also apply here.

- 1.5.1 This Rate includes excavation of soil in soft murrum , hard murrum average rate. The payment of this item shall be per Cu.M.
- 1.5.2 This Rate includes excavation of soil in soft rock , hard rock average rate. The payment of this item shall be per Cu.M.

General Instruction regarding Excavation

- * Excavation shall be in any rock or boulders having diameter in any one direction of more than 300mm for which the use of mechanical plant or controlled blasting is required. The classifications of excavation shall be decided by the Engineer-in-charge and his decision shall be final and binding on the contractor.
- * Controlled blasting shall be carried out only with the written permission of the Engineer-in-charge All statutory laws, regulations rules etc. Pertaining to the acquisition, transport, obtaining permission of respective departments, handling and use of explosives shall be strictly followed,
- * when controlled blasting is permitted by the Engineer-in-charge in writing the same shall be carried out by any method of blasting consistent with the safety and job requirements.
- * The magazine for the storage of explosives shall be built to the design and specifications of the explosive department concerned and located at the approved site. No unauthorized person shall be admitted into the Magazine which when not in use shall be kept securely locked. No matches or inflammable material shall be allowed in the magazine. The Magazine shall have an effective lighting conductor, the following shall be in the lobby of magazine.
 - (a) A copy of relevant rules regarding safe storage both in English and Gujarati
 - (b) A statement of update stock in the magazine.
 - (c) A Certificate showing the last date of testing of the lighting conductor.
 - (d) A notice that smoking is strictly prohibited.
- * In addition to these, the contractor shall also observe the following instructions and any further additional instructions may be given by the Engineer-in-charge & shall be responsible for damage to property and any accident which may occur to workman or the public on account of any operations connected with the storage, handling and use of explosives and blasting.
- * All the materials, tool and requirement used for blasting operations shall be of approved type and approved by the Engineer-in-charge. The fuse to be used in wet locations shall be sufficiently water resistant as to be unaffected when immersed in water for 30 minutes. The rate of burning of the fuse shall be uniform and known to determine its length.
- * The blasting operation shall remain in charge of competent, experienced supervisory staff and workmen who are thoroughly acquainted with the details of handing explosives and blasting operations.
- * The blasting shall be carried out during the time fixed and approved by the Engineer-in-charge. The hour of blasting

shall be made known to the people in the vicinity.

- * Red danger signals shall be displayed in all directions during the blasting operation. People except those who actually light the fire shall be prohibited from entering the area.
The flags shall be planted at safe distance from the blasting area in all directions and all persons including workmen shall be excluded from the flagged area at least 10 minutes before the firing, a warning whistle being sounded for the purpose.
- * The charge holes shall be drilled in suitable places to depths approved by the Engineer-in-charge blasting should be as light as possible consistent with required breakage of materials.
- * When blasting is done with powder, the fuse cut to the required length shall be inserted into the hole and the powder dropped in. The powder shall be gently tamped with copper rod with rounded ends. The Explosive Powder shall then be covered with tamping materials which shall be tamped light but firmly.
- * As the blasting will be only controlled one with light charges, dynamite etc. shall not be used.
- * At a time not more than the number of charges approved by the Engineer-in-charge will be prepared and fired. The charges shall be fired after observing the instructions given above and the explosions counted. The man in charge shall satisfy himself that all the charges have been exploded before allowing the workmen to go back to work site.
- * In case of misfire the following procedure shall be observed.
 - (a) Sufficient time shall be allowed to account for the delayed blast.
The man in charge shall inspect all the charges and determine the missed charges.
 - (b) In the case of blasting powder missed charge, it shall be completely flooded with water. A new hole shall be drilled about 45 cm. from the old hole and fired. This should be repeated till the old charge is blasted.
- * The man in charge shall at once report to the contractor's office and the Engineer-in-charge of all cases of misfire the cause of the same and the steps taken in connection there with.
- * A careful and day to day account of the explosives shall be maintained by the contractor in an approved manner in a register which shall be open for inspection by the Engineer-in-charge at all times.
- * The rate shall include all stipulations mentioned under 1.1 over and above these stipulations, the rate shall also include excavation by chiselling or controlled blasting as required for the work.
- * The necessary permission of the concerned district authority shall be obtained by the contractor prior to the blasting operation and all safety and necessary arrangements shall be made as per

his directions before the blasting operation is actually started. The rate shall be paid per Cu.M. and will be inclusive of necessary shoring, strutting, scaffolding, bailing out water, dewatering barricading etc. complete.

Removal of Excavated Stuff and Laying within the sites specified in Notification as directed by Engineer-in-Charge

After Refilling the pipe / chamber trenches by the excavated stuff is 15 cm thick layer, including ramming, watering and consolidating up to possible extent as specified in excavation & refilling item, the surplus stuff shall be disposed off at the following sites as directed within the prescribed limits of Notification as directed by the engineering in charge.

1. Beside Kotharia Police Station near Stone Quarry
2. All Quarry areas of Raiya Smart City

The excavated material of black cotton soil and other useful material should be stacked at the location specified by the engineer in charge.

If the contractor fails to dispose the excavated stuff as specified, penalty will be imposed by Rajkot Municipal Corporation as per the Notification for C&D waste,

After refilling surplus earth shall have to carted by the contractor within specified limit including loading transporting unloading spreading.

No payment will be made for removal of excavated stuff from site and laying of excavated stuff as directed shall have to be carried out by the agency without any extra cost.

* REFILLING THE PIPE TRENCHES BY THE EXCAVATED STUFF IN 15CM TO 60 CM THICK LAYER, CONSOLIDATING UP TO POSSIBLE EXTENT AND DISPOSAL OF SURPLUS STUFF AS DIRECTED IN DESIGNATED AREA OR AS DIRECTED BY THE ENGINEER-IN- CHARGE.

* After the sewer pipes have been laid and jointed and the manholes and vent shafts are constructed and as soon as the joints have been inspected and passed by the Engineer-in-charge and after all concrete work thoroughly set the trenches shall be fulfilled with the materials taken there from. In refilling the trenches the utmost care shall be exercised so as not to disturb, break or damage the jointed pipes. Over and around every pipes the finest selected material shall be put. No lumps of rock earth or other material shall be put around the pipe or be thrown into the trenches until the same has been broken to specified size and pipes covered by the fine material above referred to. The selected fine material shall be carefully placed next to the permanent work and well packed and well rammed in layers of 150mm for a depth of at least 300mm over the top of the pipe. The remaining of the excavation shall be filled in with the best and most suitable portions of the excavated material in layers of not more than 600 mm deep or as decided by the engineer in charge. Surplus soil shall be piled on top of the filling to the extent possible for expected subsidence. All road materials to from a compact neat surface. The contractor shall maintain all refilling

and surfaces until completion of entire work. The contractor shall be responsible for claims arising from accidents due to subsidence or inadequate maintenance or improper refilling work. Where excavated material is not considered suitable for refilling by the Engineer-in-charge, the Contractor will be required to cart selected surplus excavated materials in place of unsuitable materials. The contractor may also be instructed to supply suitable granular or other hard filling material for use in refilling such imported filling material shall be paid for at the rates given in the Bill of quantities or as per S.O.R. of Rajkot Municipal Corporation.

When trench is excavated under or near any existing work likely to be affected by subsidence of the material in the trench, or where any permanent work will be constructed later of the trench. The contractor shall fill in the trench with M 100 concrete or take such other precaution means to prevent damage by subsidence as. The Engineer-in-charge may direct, Whether such work is shown in the drawing or not, whether it is billed in the quantities or not. Any

extra work necessitated will be paid for according to the provisions of the conditions of Contract. Unless in the opinion of the Engineer- in-charge, it is necessitated by the contractor negligence, bad workmanship faulty materials or lack of reasonable foresight.

*

Subsidence in filling:

Should any subsidence take place in the filling up of the road on or about any part of the work whatsoever up to the completion of contract works the contractor shall make good the same at his own cost. In case of failure of the contractor to attend to the work, the Engineer-in-charge without notice to the Contractors shall make good the same in any way and with any material that the (Engineer-in-charge) may consider proper at the cost of the contractor. The Engineer-in-charge may, if he anticipates the occurrence of any subsidence employ watchman to give him timely notice of the necessity of making good the subsidence, and the cost of such watchman shall be charged to the contractor.

Removal of Excavated Stuff and Laying within the sites specified in Notification as directed by Engineer-in-Charge

After Refilling the pipe / chamber trenches by the excavated stuff is 15 cm thick layer, including ramming, watering and consolidating up to possible extent as specified in excavation & refilling item, the surplus stuff shall be disposed off at the following sites as directed within the prescribed limits of Notification as directed by the engineering in charge.

1. Beside Kotharia Police Station near Stone Quarry
2. All Quarry areas of Raiya Smart City

The excavated material of black cotton soil and other useful material should be stacked at the location specified by the engineer in charge.

If the contractor fails to dispose the excavated stuff as specified, penalty will be imposed by Rajkot Municipal Corporation as per the Notification for C&D waste,

After refilling surplus earth shall have to carted by the contractor within specified limit including loading transporting unloading spreading.

TECHNICAL REQUIREMENT & PROCEDURE ADOPTED FOR Providing Supplying, Lowering, Laying & Jointing pipe line for SWG PIPES

TECHNICAL REQUIREMENT & PROCEDURE ADOPTED FOR Providing Supplying, Lowering, Laying & Jointing pipe line for RCC PIPES

Other details for materials shall be as included in this tender Material Part.

3.1 Sight Rails and Boning Staves:

3.1.1 In laying the pipe sewers and constructing drains, center for each manhole must be marked by a peg. Or Otherwise as may be determined by the Engineer-in-charge. The contractor shall then dig holes and set up two posts (about 100mm X 1800mm) at each manhole at nearly equal distance from the center of the manhole. The distance shall be such that they shall be well clear of all intended excavation. They shall be so arranged that a sight-rail when fixed level against the posts will cross the center of the manhole. The posts shall also be so set up that the longitudinal direction of the rail may be as clear as possible to the direction of any of the lines pipes or drains converging to the manhole. If walls of buildings afford suitable means of fixing the sight-rail the post may be dispensed with. The sight-rail, must not in any case be more than 30 M apart. If intermediate rails between two manholes be found necessary, the same shall be put up.

3.1.2 Construction of boning staves:

Boning staves shall be prepared by the Contractor about 75mm X

50mm of various lengths, each length being of a certain number of meter and with a fixed tee-head and fixed intermediate cross piece, each about 300mm long. The top-edge of the cross piece must be fixed at a distance below the top-edge of this tee-head, equal to the outside diameter of the pipe or the thickness of the concrete bed to be laid. The boning staff must be marked on both sides to indicate its full length. According to the requirements of each case, a suitable length of boning staff will be fixed and the reduced level of the bed of the pip or bottom of concrete of drain at each sight-rail place added to the selected length of boning staff, and marked by a horizontal line in both posts, or on walls or fences to which the sight-rail is to be fixed.

3.1.3 Sight Rails:

The sight rails (about 25 mm wide and 40 mm thick) are to be screwed with the top-edge against the level marks. The center line of the pipe sewer or the drain will be marked on the rail and this mark will denote also the meeting point of the center of any converging drains or pipe sewers. Line drawn from the top-edge on rail to the top-edge of the next will be vertically parallel with the bed of the sewer or drain at any intermediate point. This could

be easily determined by letting down the selected boning staff until the tee-head comes in the line of sight from rail to rail. The posts and rail are to be perfectly square and planned smooth on all sides and edges. The rails are to be painted white on both sides, and the teak-hands and cross pieces of the boning staves are to be painted black. If the pipes or domains converging to a manhole come at different level there must be a rail fixed for every different level. When rail comes within 1.6 M of the surface of the ground a higher sight-rail shall be fixed for use with the rail over the next point. Posts and rails shall in no case be removed until the trench is excavated. The drains are constructed, the pipes are laid and permission given to proceed with the filling in.

3.2 LOWERING LAYING AND JOINTING OF PIPES:

3.2.1 Contractor to obtain permission before laying pipe, concrete or Construction of masonry:

When any portion of the excavation shall have been carried out to the necessary depth, the contractor shall obtain permission in the Engineer-in-charge before commencing the work of laying of pipes or concrete or the construction of masonry. No sewer pipe shall be allowed to be laid over and parallel to the water supply pipeline. Sewer line shall be laid below the water supply pipeline irrespective of the size of the pipeline.

3.2.2 Handing of pipes:

At every point of loading or unloading, pipes or fittings shall be handled by approved lifting tackle. Unloading by rolling down planks or any other form of inclined ramp shall not be allowed unless the written approval of the Engineer-in-charge is obtained regarding the same. Pipes shall be carefully stacked on site with timber packing under and between the pipes without causing nuisance or obstructions to traffic of walkway.

3.2.3 Laying:

The pipes shall be laid up the gradient beginning at the lowest end. No pipe shall be laid until the trench has been excavated to its required depth for a distance of 20 M in front of the pipe to be laid (This distance may vary as directed by the Engineer-in-charge). All the pipes shall be laid perfectly true, both in line and in gradient. The

pipes in a trench shall be all laid and fitted previous to the jointing

being commenced properly fitted temporary wooden stoppers shall be provided and constantly added to close the ends of all in-completed pipelines. The stoppers are to be removed only when pipes are laid and jointed.

3.2.4 Jointing of stoneware glazed with Socket and Spigot Joints:

The laying and jointing of pipes shall conform to IS : 4127 (1967) The pipes shall have socket and spigot joints. The trench shall be checked for proper level, gradient and alignment before lowering the pipes. The laying of the pipes shall properly up-grade of slopes. The socket end shall always be facing the up-stream end of the trench.

All joints shall be filled up with hemp yarn dipped in sufficient quantity of cement slurry, cement mortar 1:1 shall be forced into joint by using cocking tools etc as directed by Engineer-In-Charge until the whole space around the spigot between it and the spigot is full so as to form a neat fillet round the pipe.

The cement mortar joints shall be cured at least for seven days.

3.2.5 Jointing of RCC pipe with Socket and Spigot Joints:

The RCC pipe with the rubber ring accurately positioned on the spigot shall be pushed well home into the socket of the previously laid pipe by means of uniformly applied pressure with the aid of a jack or similar appliance. The RCC pipes shall be of spigot and socket type and rubber rings as specified in IS-458-2003, shall be used, and the manufacturer's instructions shall be deemed to form a part of these specifications. The rubber rings shall be lubricated before making the joint and the lubricant shall be soft soap water or an approved lubricant supplied by the manufacturer.

Socket & Spigot NP3 & NP4 pipe with rubber ring roll on joint for diameter upto 900 mm should be provided as per table 14 of IS 458:

2003. Socket & spigot NP3 & NP4 pipe with rubber ring confined joint for diameter 1000mm to 2600 mm should be provided as per Table -

17 of IS
458:2003.

3.2.6 All works to be Water Tight:

The drains, manholes and all joints of pipes shall be made thoroughly sound and water tight and any joint which may be observed to be leaky at any time during the progress of the works or during the contractor's subsequent period of maintenance shall be immediately made good by the contractor at his own cost. The contractor at his own cost shall have to carry out satisfactory flow test as directed by the Engineer-In-Charge. In case of any dispute in this regard, the decision of Engineer-In-Charge shall be final and binding to the contractor.

3.2.7 Inspection of joints:

After the joints of any pipes in under ground work have thoroughly set the Engineer-in-charge (or any person whom he may appoint) may inspect the joints and if he has any doubt as to their soundness he may request the contractor to open out and clean the cement. Contractor shall not be required to open more than one joint in 20 M of pipe. However, if the defect is found, the Engineer-in-charge may direct him to open as many joints as he may deem necessary.

3.2.8 Cleansing of the pipes:

As soon as a stretch of pipeline whether of stoneware or cast iron or RCC pipes has been completed between two manhole, the contractor shall run through the pipes both backwards and forwards a double disc / solid / closed cylinder 75mm less in dia, than the internal dia of the pipes wherever required and suggested by the Engineer-In-

Charge. The open end should be closed as may be directed by the Engineer-in-charge to prevent, entry of mud or silt etc. If as a result of the removal of any obstruction in the pipe line the Engineer-in-charge considers that damages may have been caused to the pipeline, he shall be competent to order the length to be tested at the expense of the contractor. Should such retest prove unsatisfactory the Contractor shall at his own expense amend the work and carry out such further tests as may be required by the Engineer-in-charge. It shall also be ascertained by the Contractor that each stretch from manhole to manhole is absolutely clean and without any obstruction by means of visual examination of the interior of the pipeline suitable illuminated by projecting sunlight or artificial light.

3.2.9. Cracks in Pipes:

In the event of pipes being cracked after being properly laid either due to improper loads having been encountered or the material of refilling having been improperly selected or because of any other cause, the Contractor in every case shall be held responsible and will be called upon to replace such cracked pipes at his own cost during the expiration of period of maintenance.

Any pipe or length of pipes found to be defective shall be immediately removed and replaced at the Contractor's expense and leaking joints shall be remade. The inspections and tests shall them be repeated as often as necessary until the whole line under inspection or tests is accepted by the Engineer-in-charge.

3.2.10 All works to be clear, clean and perfect:

The contractor shall after completion or whenever required by the Engineer-in-charge, prove all pipes and fittings to be clear and perfect, for this purpose he shall at his own expense and in the presence of the Engineer-in-charge or his appointee, provide suitable instruments and appliances and pass them through the pipes and if required shall pass water and show that it passes freely through every portion of the work. Brick mortar and rubbish shall not be allowed to fall into the manholes of sewer lines while fixing or if fallen shall be removed by the Contractor at his own expense.

3.2.11 Pipe entering and leaving manholes :

Whenever a pipe enters or leaves manhole, the ends of all pipes shall be properly built-in and neatly finished with cement mortar. The pipe projections are to be cut so that the ends are flush with plastered surface of the manhole, nothing extra shall be paid for this. The rate of pipe laying include this work also.

3.2.12 Fittings:

The terms fittings as used in this specification is intended to apply to any and every article used in combination with straight pipe itself. In the areas subject to subsidence, the pipe sewer should be laid on suitable supports or concrete cradle supported on piles.

3.2.13 Measurement of pipe lines:

- (a) All pipelines shall be measured according to the work actually done and no allowance shall be made for sockets and any wastage in cutting to the exact length required. A bend, junction, or any other piece of fitting which may have necessarily been out for the exigencies of the work will be taken into account as if whole, provided that the cutting has been done properly and that portion used in the work is sound. This clause shall not apply to a straight pipe under any circumstances. In measuring the lengths of pipes laid, deductions shall be made for the lengths of channels between the inside faces of the walls of manholes.
- (b) Payment for providing, supplying, lowering, laying, jointing and testing of R.C.C. and SWG pipes shall only be made after laying & Backfilling for the same as under:
- (i) 90% payment of this item shall be paid after lowering, laying and jointing pipes as per specifications.
 - (ii) Remaining 10% payment shall be paid after satisfactory flow test.
 - (c) For providing, lowering, laying, jointing and testing work, payment shall be made only for completed section between manhole to manhole. No payment shall be made for incomplete sections.

Tender Item

Providing & Construction Sewer Manhole

Tender Item

& House Connection Chambers

APPURTENANCES :

(Manholes, drop manholes and scraper Manholes & house connection chamber) providing and constructing sewer manholes as per the type design in brick masonry in CM 1:3 including C.C. 1:3:6 in foundation and M-150 in benching, inside plastering C.M. 1:3 and outside plastering in C.M. 1:3, coping in R.C.C. M-250 on all manholes, providing and fixing manhole frame & covers (but excluding supply of manhole frame & covers) complete, as per the stipulation in the type design complete as per the drawing attached. All other details for materials shall be as included in this tender Material Part.

Manhole type 'A1', 'A', 'B', 'C', 'D1', 'D2', 'D3', 'S1', 'S2', T.

The type of Manhole to be constructed shall be decided by the Engineer- in-charge depending upon the technical requirement, actual site condition, likely future expansion, economy etc. and the contractor shall have to carry out the work according to the instructions of the Engineer-in-charge.

5.1 THE MANHOLE AND DEPTH OF MANHOLES:-

The manholes on the sewers shall be constructed in the form and of the dimensions shown in the Drawing. The depth of the manholes shall be measured from the top of cover to the invert level of the manhole.

The manholes shall be constructed at places shown on the drawings or whatever directed by the Engineer. Type designs for these manholes are shown on the drawings but the actual type and dimensions shall in each

case be determined by the Engineer as the circumstances may require.
(Refer drawing attached)

5.2 CONSTRUCTION OF BRICK MASONRY MANHOLES:

The brick masonry shall be constructed as per the type design shown in the drawing enclosed. The various types of manholes to be adopted as per the requirement have been indicated in the L-section and sewer layout drawing in general. The manhole will be fitted with R.C.C. pre-cast medium or heavy duty manhole frame and cover as the case may be. The brick masonry manhole shall be plastered from inside and outside as shown in the drawing and as shown CM proportion and thickness. .

5.3 FLOORS AND 0.80 ID CHANNEL PIPES:

The floor shall consist of cement concrete. Concrete of R.C. 0.80 ID channel pipes of the required size and curves shall be laid and bedded in cement on the concrete base to the same lines and fall as sewers unless otherwise directed. Both sides of the channel pipes shall be trenched up in concrete and rendered in cement mortar 20 mm thick and formed to a slope of not less than 1 in 12 to the channel.

5.4 STEPS:

Where the depth of the invert exceeds 0.90 M below the surface of the ground, HDPE reinforced steps of approved pattern shall be provided as per type design shown in manhole drawings.

5.5 RATE OF MANHOLES:

The rate for construction of manhole to be quoted in the bill of quantities shall include complete masonry, structure, concrete cap, plastering with cement from inside and outside, bottom concrete or channels including providing and fixing of HDPE reinforced steps and fixing of R.C.C. Manhole frame & covers (but excluding supply of manhole frames and covers) complete as per type design drawing and cutting the pipes flush with the inside plaster of the wall. The manholes will be paid per numbers up to the minimum depth shown in the type design and for depth beyond the specified minimum depth for a particular type of manhole; extra will be paid per running meter depth. The rates include dewatering during all stages of construction.

Providing & Construction House connection chambers as per type design

Brick masonry chambers for house connections. HC-1 and HC-2.

Tender Item

.... above 0.60 mt. depth (Deleted)

Tender Item

.... below 0.60 mt. depth (Deleted)

RATE OF house Connection Chambers

The brick masonry chambers for house connection will be paid

per number excluding excavation but including masonry, bottom concrete, plastering, benching channel fixing of RCC frame and covers (but excluding supply of manhole frames and covers). (Refer. R.M.C. DRG No.- & - for H.C.1, H.C.2)

GENERAL :- The R.C.C. pre-cast manhole cover shall conform to IS – 12592 / 2002 or its latest version and as per detailed Drawing attached herewith.

ii) SHAPES & DIMENSIONS :-

Shapes :- The shapes of pre-cast M.H. covers shall be circular only and 10 and 20 MT capacity for MHS and 5MT for HC chambers.

ii.a) DIMENSION & TOLERANCES: - length, breadth & diameter of pre-cast concrete manhole covers shall be such that the maximum clearance at top between the frame & the cover shall be 5mm. The minimum thickness of HD, MD & LD Covers shall be 90, 70 & 60 mm respectively.

Other details for materials shall be as included in this tender Material Part.

..... Providing & Supplying of Pre-cast RCC Frame & Cover - 5 T Capacity (Round) (Deleted)

Tender Item

6.1 Providing & Supplying of Pre-cast RCC Frame & Cover - 10 T Capacity (Round)

Tender Item

6.2 Providing & Supplying of Pre-cast RCC Frame & Cover - 20 T Capacity (Round)

Tender Item

7 Breaking of Pavement surface

BREAKING OF ASPHALT SURFACE:-

In this works, breaking of Asphalt surface is to be done as directed by Engineer-in-charge. For any damage to Gutter or Manhole due to breaking of asphalt surface, contractor is responsible for repairs. No extra payment will be paid for such work.

EXCAVATION OF ASPHALT PAVEMENT

Under this item contractor shall demolish existing asphalt or WBM pavement met with during laying of RCC or SWG pipes. Only area of pavement intercepted in pipe laying shall be demolished. If excess area is demolished same shall be reinstated by the contractor. Work done to the extent of requirement for laying of drain and as per specifications shall measured in sq.m. and paid at the tender rate.

Tender Item

7.1 Breaking of Pavement surface- Conventional Finish

Tender Item

7.2 Breaking of Pavement surface- Paver Finish

Payment will be made per square meter of work done.

Tender Item

- Manhole road level as per type design

This includes Making Manhole Road Level finishing for all type of existing manhole up to 0.30 Mtr. height in in brick masonry walls of Manholes & repair the same after correction work with Cement Mortar CM (1:3) with C.C. (1:1:2) Coping work for Frame Cover including Manhole cleaning, unloading rubbish etc.

Payment will be made per Number of work done.

Tender Item

- Making hole and repairing work in Manhole

This includes Making hole in brick masonry walls of Manholes & repair the same after connection work with Cement Mortar CM (1:3).

Payment will be made per Number of work done.

Tender Item

PROVIDING SAND INCLUDING RAMMING, WATERING, CONSOLIDATING ETC. COMPLETE.

The sand shall be river sand preferably BHOGAVO Sand and shall be of round shape particle. crushed stone will no be allowed as bedding. The same to be used for bedding shall be got approved from Engineer-in-charge before using the same for providing bedding on trench bed.

The providing of sand for bedding shall be done in required thick area as per drawing (DRG No.14) or as instructed by Engineer-in-charge. It shall not contain dust, clay or other such harmful materials. If directed the sand shall be washed with water and screened before being used. The sand containing big clods shall be broken into small pieces. The tree's roots, meets, bit stones and other objectionable materials liable to decay shall not be used in the work. Sand brought from approved source shall only be used.

C GENERAL MATERIAL SPECIFICATION

1.0 CONCRETE:-

1.1 Cement Concrete (plain or reinforced) :

All cement concrete to be used in the work shall conform to the requirements of I.S. 456.

1.2 Materials:

1.2.1 Cement:-

All cement for use on the works except otherwise stated shall be the standard ordinary Portland cement manufactured in India and shall conform to the IS:269, IS : 8112, IS:12269 or latest versions. It shall be of the make and quality approved by the Engineer.

(For this work, approved makes are Ambuja, Sidhi, L&T, Sanghi, Lotus, Hathi or equivalent. Mini cement plant cement shall not be allowed).

The cement shall be stored in weather proof godown or cement store specially constructed for the purpose in such a manner as to prevent deterioration due to moisture of instruction of foreign matters.

The weather proof godown shall have a soil impervious floor raised 300mm above the general ground level so that the cement stored thereon shall not come in direct contact with sub soil moisture. The passage and the general construction shall be such that it offers full protection from weather effects. Large stocks of cement shall not be kept at the works but only sufficient quantities should be kept to maintain continuity of the work.

1.2.2 Storage of Cement:

No cement that has been stored for more than 90 days shall ordinarily be allowed to be used in the works Cement stored for longer period than 90 days shall be used only after approved by the Engineer-in-charge who shall ascertain its quality before giving such permission.

The Contractors shall offer every facility to the Engineer for inspection of cement. The cement go down shall be so arranged by the contractor that each consignment could be stacked separately and in such a manner so as to allow counting of bags in each row with ease.

The cement, used in any type of concrete shall always be measured by weight and one cubic meter shall be taken as weighing 1440kgs. (Table 30 of A.C.C. hand-book)

1.2.3 Aggregates:

All the aggregates shall conform to the latest IS : 383 The aggregates shall consist of naturally occurring sand and gravel or stones crushed or uncrushed or a combination thereof. They are classified broadly under two categories viz.(i) sand of fine aggregates and (ii) coarse aggregates, depending, upon their sizes. The fine aggregates, those which pass through Is sieve No.480 and the coarse aggregate are those which are retained on the IS sieve No.480.

1.2.4 Storage of aggregate:

The fine and coarse aggregate shall be stored separately and in such a manner that segregation of the various sized particles shall not occur, the stock piles shall be formed on platform of weak concrete timber of similar approved hard standing and aggregate shall be kept clean and free from foreign substances. Storage piles of aggregate shall be arranged with proper drainage and protection from rainfall in order to prevent excessive changes in moisture content taking place during concreting.

The aggregate both fine and coarse shall be hard, strong, durable, clean, free from veins and adherent coatings. The use of flaky and elongated pieces of aggregates shall be prohibited.

The aggregates shall not contain deleterious materials such as iron pyrite, coal mica, shale or similar laminate material, clay, alkali, soft fragment sea shells, organic impurities etc in such quantity as to effect the strength of durability of concrete or the reinforcement embedded in such reinforced concrete.

1.2.5 The maximum quantities of deleterious materials that may be permitted shall conform to the following limits by weights.

Deleterious Substances	Fine P.C. by weight		Coarse aggregate P.C. by weight	
	<u>Uncrushed</u>	<u>Crushed</u>	<u>Uncrushed</u>	<u>Crushed</u>
1) Coal and lignite	1.00	1.00	1.00	1.00
2) Clay lumps	1.00	1.00	1.00	1.00
3) Soft fragments	---	---	---	---
4) Materials passing through 75 micro sieve	3.00	3.00	3.00	3.00
5) shale	1.00	---	---	---

The total of various deleterious materials in any sample shall in no case exceed 5 per cent. If the aggregate supplied is unclean, it shall be washed. If it is not properly graded, it shall be screened by hand or by mechanical means and the various sizes proportioned to get the required grading.

Storing of aggregates on dusty, muddy and grassy spots shall be avoided. They shall be stored on the works in such a manner as to prevent foreign matter and protected from exposure to dust. They shall be placed in stock piles in individual units of suitable sizes and in suitable layers to prevent segregation. They shall not be allowed to run down slopes.

1.2.6 Sand or fine aggregates:

All fine aggregates shall consist of clean, hard strong durable uncoated siliceous gritty materials consisting of well graded particles obtained from rock, fragments. It shall be free from clay lumps, injurious amounts of

dusts, mica shells, soft or flaky particles shale, alkali, organic matter, lead or other deleterious substances.

The sand shall be taken from source approved by the Engineer. The sand or fine aggregates shall conform to the latest IS No.383

If the Engineer considers it necessary, it shall be washed and or screened before use, all the expense of the contractors.

The sand shall have a fineness modules of not less than 2.5 and not more than 3.0 and the grading shall conform as far as possible to the following analysis :

I. S. Sieve No.	Percent passing	
	Natural sand or Crushed gravel.	Crushed Stone.
180	95 - 100	90 - 100
240	70 - 95	60 - 90
120	45 - 85	40 - 80
60	25 - 60	20 - 50
30	5 - 30	5 - 30
15	0 - 10	0 - 15

The specific gravity of sand shall not be less than 1.6. In on case shall fine aggregate be accepted containing more than 2 per cent by dry weight, not more than 2 ½ % by dray volume, not more than 5 percent by wet volume of clay, loam or silt, any sample of fine aggregate shows more than 5 per cent of clay, loam or silt, in one hour's settlement after shaking in an excess of water the lot represented by the sample shall be rejected.

1. The following two field tests are recommended for ascertaining the percentage of clay lumps and impervious organic material and the contractor shall carry out the same if the Engineer-in-charge deems necessary.

(1) Test for determining silt in sand :

Fill a calibrated tumbler with same to half its volume and add water there to until the fill a calibrated tumbler is three quarter full shake up the mixture vigorously and allow it to settle for about an hour. The volume of silt visible on top of the sand shall be measured. If the volume of the its standing over the sand exceeds 5 per cent of the total volume of sand same shall be rejected.

(2) Colorimetric test for organic impurities :

The sample of sand shall be mixed with equal volume of 3p.c. solution (about one ounce in a quarter of water) of caustic soda / sodium hydroxide taken in a plain glass an the mixture shall be allowed to stand for 24 hours. The liquid standing above the sand shall not be darker than

lights straw (pale yellow) colour. If the color is marked yellow or brown, then test would indicate presence of organic materials in excessive amount.

In case suitable sand is not available in adequate quantities within a reasonable and economical limit, the contractors may be allowed the use of crushed or pulverized stone or gravel either alone or mixed with natural sand in parts. The stone or gravel shall be clean, sharp and free from dust etc. and shall conform to the latest I.S. 383. In this case, approval of Engineer-In-Charge shall be obtained.

The percentage of crushed stone to be mixed with sand shall be such as to obtain the fineness modulus of the blended sand within the limits specified above, and or approved by the Engineer after Laboratory tests.

1.2.7 Coarse Aggregates:

All coarse aggregate used in concrete works shall consist of crushed rock gravel or other approved inert materials.

Broken or crushed rock from sound blue basalt or black trap zeolite shall be used in concrete as coarse aggregate. The particles of aggregate shall be clean, hard, tough, durable, free from deleterious substance and shall contain no soft, flat or elongated pieces. The coarse aggregate shall have specific gravity not less than 2.6 and the water absorption measured after being immersed for 24 hours in water shall not be more than 6 per cent by weight. The maximum percentage of deleterious materials in the coarse aggregate shall not exceed 5 per cent by weight in the aggregate when tested in conformity with IS No. 363.

The nominal size of the coarse aggregate for reinforced concrete work shall be 10 to 20 mm. Larger coarse aggregate up to 40mm size may be used if approved by the Engineer in plain concrete work. The maximum size of coarse aggregate shall be as large as possible within the limits specified but in no case shall be greater than one quarter of the minimum thickness of the member, provided that the concrete can be placed in the formwork without difficulty so as to surround reinforcement thoroughly and to fill the corners of the formwork. The minimum size of coarse aggregate shall be as mentioned earlier such as to retain most of the material (90 per cent, 95 per cent maximum) on IS sieve No. 480.

Aggregating shall be screened and, if necessary, blended to give the required grading when tested in the Laboratory at Contractor's cost by means of standard mesh sieves, the grading shall fall within the following limits:

Sieve size.	Percentage retained by weight	
	Plain C.C.	R.C.C.
40 mm	-----	-----
25 mm	10 to 15	-----
20 mm	35 to 40	15 - 0
10 mm	37 to 80	100 - 80
No.480	98 to 100	100 - 95

The percentage given above are for guidance and the Engineer-in-charge reserves the right to modify the same to any other lower or higher value if considered necessary by him, according to the requirements of the work.

In the event of undesirable segregation occurring in coarse aggregating in two or more suitable fractions as directed.

The grading so specified shall be such as to give a dense, water tight concrete of specified proportion and strength and required consistency. The Engineer shall have the right and authority to carry out routine control tests and analyses of the broken rock at any stage of the work processing and / or concreting operations and the contractors shall give necessary facilities in respect of such testing. The sampling and testing shall be carried out, as per standard IS practice entirely at the cost of the contractors.

1.2.8 Water:

The water used for the preparation of concrete, for washing sand etc. and for curing shall be clean and free from objectionable quantities of silt, organic materials, acid, alkali, salts, oil and other deleterious impurities and it shall be obtained from the source approved by the engineer. Potable water shall be obtained from the source approved by the Engineer. Potable water shall generally be found fit for preparation of concrete. The quantity of water to be added for making concrete shall be properly measured and controlled.

1.3 Water Cement Ratio:

Suitable water cement ratio for the different mixes and use shall be determined in consultation with the Engineer and shall generally not be exceeding 0.5 (i.e. 50 percent by weight) The exact value being fixed after taking into account all relevant factors such as strength required, weather condition, water absorbed by material, workability and slump required consistent with the work requirements, methods of compaction etc.

1.4 Concrete:

All cement concrete whether used in R.C.C. work or plain concrete work shall be designated in grades by the strength at the age of 28 days) M 100, M 150, M 200 & M 250 where M refers to the mix and the number 100, 150, 200 and 250 represent the specified 28 days works cube compressive strength of the mix under reference, expressed in Kg/sq cm. The proportions of cement, aggregate water for ordinary cement concrete shall be as designated below and shall generally consist of quantities as given in the table below per bag of cement.

TABLE No.1:– Concrete mix proportion for ordinary concrete.

Grades of Concrete	Total quantity of dry aggregates (Fine and coarse) by volume per 50kg. (Max.in liters).	Quantity of water per 50 kg. Of cement (Max. in liters)
M-100	300	34
M-150	220	32
M-200	160	30
M-250	100	27

The proportion of fine aggregate to coarse for the various mixes listed above shall generally be 1:2 by volume but variation from 1:1 ½ to 1:3 depending upon the grading of the aggregates may be permitted by the Engineer. The quantity of fine and coarse aggregates, however, shall not in any case exceed the quantity given in the above table No.1.

The cement concrete shall be tested for compressive strength at the age of 28 days on 15 cm. Cubes in accordance with the latest IS : 516 and the strengths developed for all type of concrete shall not be less than those given in Table-2.

TABLE –No.2:- Strength requirement of concrete.

Grades of Concrete	Minimum Compressive strength of cubes at 28 days in kg / cm ²	
	Preliminary Test	Works Test
M-100	135	100
M-150	200	150
M-200	260	200
M-250	320	250

For quick results the contractors shall carry out compression tests on 15 cm cubes cast in accordance with relevant IS 516 at 7 days in addition to the normal 28 days compressive strength. The 7 day strength of the various concrete mixes shall not be less than the values given in the Table NO.3 below. However the 28 days compressive strength alone shall be the criterion for acceptance or rejection of the concrete unless the Engineer is satisfied of the relation between the 7 days compressive strength and the 28 days compressive strength, established by carrying out a number of tests, in which case, he may relax the test frequency of 28 days compressive strength specified hereinafter.

TABLE –No.3: - Optional test requirement of Concrete

Grades of Concrete	Minimum Compressive strength on 15cm. Cube at 7 days in Kg / cm ²
M-100	70
M-150	100
M-200	135
M-250	170

All test strength specified above are exclusively for 15 cm size cubes and they shall be adequately modified to suit the requirement of 15cm dia and 30 cm long cylinder moulds wherever used in the case of cylinder the strength values obtained should be multiplied by 1.25 to obtain the equivalent cube strength.

1.5 Control and Testing of concrete.

The following tests shall be carried out at site whenever required by the Engineer in accordance with IS 516

1. Works tests – 7 days and 28 days compressive strength
2. Consistency test.
3. Moisture contents in aggregates.
4. Unit Weight of concrete.

(1) Works test:

During concreting operations samples of concrete as placed in the work shall be taken every day and set of six cubes or cylinder shall be made there from for being tested for their compressive strength. The consistency (slump) test shall also made and the slump recorded.

All concrete cubes or cylinders shall be tested for compressive strength as specified under IS 456 and 516 at the approved material testing Laboratory generally as per specification under the latest IS 456 and IS 516. The above, specification cover concrete mixes of grade M-100 and above. Ordinarily it is not necessary to test the compressive strength of mix of grade M 100 as it is generally used for non structural purposes. However, where this mix (M 100) is used extensively on works (i.e. more than 75 cu.m. of concrete is to be placed one time in any work) it shall be tested in the same manner as other grades of concrete used for structural purposes. The minimum strength of various grades of concrete both at the age of 7 days and 28 days are given in Table 2 and 3.

In the case of concrete of mix M 150 and above, the above, the Engineer-in-charge may not insist on the testing of concrete if the quantity of concrete to be laid on any particular day is less than 10 cum. if however the quantity exceeds 10 cum, test specimen must invariably, be taken and sent to the Laboratory for testing.

Specimen shall be made for every sample and three of them tested for 7 days strength as mentioned earlier the 28 day strength of concrete shall alone form the criterion for acceptance or rejection of the concrete. With this point in view, the concrete sample shall be tested both for 7 days strength as well as 28 days strength at the start of the work and this shall be continued until the Engineer is satisfied that proper relation between the 7 days compressive strength is established, in which case he may decide to relax frequency of testing the concrete cubes for the 28 days compressive strength.

If the average strength of the specimen tested at the time of 28 days is not less than the strength specified in Table – 2, the test shall be considered satisfactory subject to the condition that only one out of 3 consecutive tests may give a value less than specified strength but not less than 90 per cent of the specified strength. If the tests are unsatisfactory, the contractors shall take immediate steps to carry out remedial measures as may be directed by the Engineer in respect of such works, entirely at the risk and cost of the contractor. Failure of a sample in test may entail partial or whole demolition of such work, heavy penalties, black listing of the contractors concerned and or such other similar steps. The results of the tests conducted at the approved material testing Laboratory shall be taken as final and binding on the contractors. In case of any dispute, the decision of the municipal commissioner shall be binding to the contractors.

A record showing the location of test specimen and daily progress of the work done shall be maintained by the Engineer-in-charge and shall be countersigned by the contractors or their representative. In case record maintained by the Engineer-in-charge is not signed by the contractor or their representative the record kept by the Engineer shall be considered as correct and binding on the contractor. In the case of any disputes, the decision of the Rajkot Municipal Corporation shall be binding to the contractor. The contractor shall deliver the specimen for testing at the approved Laboratory at the own cost in their moulds. The contractors shall pay usual testing fees for the tests carried out in the Laboratory. These fees may vary as sanctioned by the competent authority.

(2) Consistency slump test:

The workability of concrete shall be checked at frequent intervals. The slump test shall be carried out in accordance with the standard methods given under I.S. specifications mentioned above. The slump shall be as small as practicable consistent with the efficient working and compacting of concrete. The slump shall not exceed 64 mm but the Engineer may under exceptional conditions, permit higher slump up to a limit of 150 mm.

The standard consistency test shall be applied very time at each mixer when test cubes are taken for the works of compressive strength test.

(3) Moisture Contents in the aggregates:

The moisture contents in the aggregates shall be determined in the field in accordance with the latest I.S. 2286 (Part – III) methods of test for aggregate for concrete.

(4) Unit weight of concrete.

It shall be determined by placing representative samples of concrete in a unit measures capacity and vibrating at extremely by shall vibratory or hand compacting to represent actual placing by conditions. The top of the concrete shall then be made truly flush with the top of the mould and the weight of concrete per cum. determined after curing and draying. The weight of dry concrete shall be between 2400-2625 kg / cum.

A complete record regarding various tests carried out at site and in the Laboratory shall be kept by the Engineer. The contractors shall provide at their own cost facilities for labour, material, and transport etc, required for the proper execution of the above tests. Any concrete, which does not comply with the above requirements, shall be liable for rejection by the Engineer.

1.6 Transporting Concrete:

The concrete shall be transported in clean metal buckets burrows, dumpers or trucks and the written approval of the Engineer must be obtained before any method involving the use of concrete pumps, placers, pipeline, chutes, or spouts may be used.

1.7 Placing Concrete:

- (a) Unless otherwise approved, concrete shall be placed in a single operation to the full tackiness of slabs, beams and similar members and shall be placed in horizontal layers not exceeding 600mm deep or 230 mm when manually compacted in walls columns and similar members.
- (b) The contractor shall so organize has work that once concerting of a particular section of the work has started the operation shall be continued and each operation shall be completed prior to a stoppage for meal, etc. the contractor's attention is drawn to the requirements regarding the formation of construction joints.
- (c) Where concrete is to be placed directly against the surface of excavations all soft material and debris shall be removed from the contact surfaces which shall be made dry, clean and firm. If the contact surfaces have become softened due to delay in placing the concrete or any other cause, they shall again be excavated to firm material and trimmed as directed immediately before the concrete is placed. The contractor in such event shall receive no payment for

the additional excavation and trimming or for any additional concrete required to replace the material so removed.

- (d) Concrete shall be well compacted between and round the steel reinforcement by approved means so as to ensure compact concrete with smooth surfaces, without air holes, flaws or voids. Great care shall be taken to prevent the displacement of the steel and form work before during or after concreting. Whenever possible all reinforcing members shall be fixed in position before the concreting has been started and securely wired together to prevent movement. Reinforcing members which must be inserted during the concreting shall be placed with the greatest care to ensure their perfect location in the finished work.
- (e) Care shall be taken to prevent men engaged in placing concrete from introducing clay or other foreign matter into the concrete of form work by means of their body in any other way.

1.8 Compacting:

Concrete shall be properly compacted by use of vibrators or by rodding and spreading as directed by the Engineer. Tamping as above shall be continued until all the entrained air is removed and the concrete has been compacted and completely fills the form. The sides of the form work shall be gently tapped by spades during concreting.

1.9 Curing of Concrete:

All concrete work shall be protected from directed rays of the sun. The exposed surface shall be kept wet for a minimum period of 10 days or for such longer periods as may be directed by the Engineer-In-Charge, Concrete laid shall not be disturbed and shall be suitably protected from any injury until completely set, particular care shall be taken at all corners and edges of the member. All horizontal concrete shall be constantly wet by ponding or in any clear manner approved by the Engineer till the time of next pouring regardless of time. Concrete surface shall be cured either by sprinkling or by spraying water or by adopting any other method to keep the area moist. Flat or fine vertical surfaces may be covered with dump gunny bags and watered frequently water used for cut for shall be clean and free from any excessive silt, coloring matter or other impurities which may stain the finished work. In order to ensure adequate quantities of water for curing, the contractors shall make necessary arrangements such as providing sufficient lengths of temporary pipe lines of suitable size, storage of water in tanks and / or sufficient nos. of bhisties.

1.10 Concreting through water:

Concrete shall not be deposited under water without the prior consent in writing of the Engineer-In-Charge. In the event of permission being given the amount of cement in every batch shall be increased by twenty five per cent entirely at the expense of the contractor and he shall take every reasonable precaution to ensure that cement or fine aggregate is not washed out of any concrete so deposited by any flow of water.

1.11 Finish of Concrete:

On removal of the shuttering and after the approval of the Engineer-In-Charge, honeycombed surfaces shall be made good immediately by the method approved by the Engineer. Superficial water and air holes shall be filled in. Unless instructed to the contractor the faces of exposed concrete placed against shuttering shall be rubbed down with a carborandum stone immediately upon removal of the shuttering to remove fins or other irregularities. The face of concrete for which shuttering is not provided other than a slab, shall be smoothed with a wooden float to give finish equal to that of the rubbed down face where shuttering is provided. No cement wash master or paint may be applied to any concrete surface without the express instruction or permission of the Engineer.

1.12 Sulphate resisting and rapid hardening cement concrete:

Where sulphate resisting or rapid hardening Portland cement is specified or ordered by the Engineer in writing, extra cost will be paid over the price for a Portland cement concrete of similar grade.

1.13 Permission for starting the concrete work:

The surface where concrete or rock or form etc. on which concrete is to be placed, shall be got inspected and approved by the Engineer who shall then issue the permission for starting the work. Any concrete work done without such a permission shall be cut out and removed at the cost of contractors.

No concreting shall be started unless the surface of the foundation is first inspected and approved by the Engineer as stated above. If concreting is to be done on concrete previously laid, the surface of the old concrete shall be cleaned with wire brushed and all laitance removed to expose the original surface of metal and sand particles, etc. it shall then be covered with a 7 mm thick layer of cement mortar (1:2) before laying the fresh concrete.

1.14 Defective concrete:

The defective concrete shall be cut out and the work reconstructed with fresh concrete required quality in the presence of the Engineer. The concrete thus cut out shall not be reused under any circumstances. Should any concrete become permanently damaged due to creaking or broken or damage from whatever cause or should any concrete be found defective in quality due to honey combing or bad workmanship, it shall be removed forthwith and replaced by concrete of required quality at the cost of the contractors of the satisfaction of the Engineer.

2.0 FORM WORK:

2.1 Material:

All form work for concrete works shall be made either of planned and matched timber or MS plates. The timber for the form work shall be hard wood dry and well seasoned. It shall not be so dry as to absorb water from concrete nor shall it be so green as to shrink after erection. When steel plates are used for forms, the plates shall be free from wrinkles, dents, lumps or other imperfections. The timber or steel plates shall have sufficient thickness to withstand the construction loads and the pressure exerted by the wet concrete as well as vibration during placing of concrete.

Normally the thickness shall not be less than 38mm for timber and 18 gauges for M.S. plates. However, in case where the depth of concrete to be poured in the form work is small the thickness of timber planks may be reduced in consultation with the Engineer.

2.2 Removal of form work:

In no circumstances shall forms be struck off until the concrete reaches adequate strength as required or without obtaining permission of the Engineer. All form works shall be removed without such shock or vibration as would damage the concrete. Before the soffit and the struts are removed, the concrete surface shall be exposed where necessary in order to ascertain that it has hardened sufficiently.

2.3 Surface treatment and finish:

When the form work is struck all the faces of concrete shall be smooth and sound, free from voids and air holes. Any roughness or irregularity on the exposed surfaces shall be immediately filled up while the concrete is still green with cement wash and or 1:1 ½ cement mortar properly trowelled and finished. Such patching of the concrete face shall be carried out with the permission of the Engineer. If the concrete is found honeycombed the honeycombed portion and whatever surrounding the Engineer shall be dismantled and fresh concrete of proper quality shall be reinstated at Contractor's cost.

3.0 REINFORCEMENT:

The total reinforcement to be used on the work shall conform to the specification of the latest IS: 1139, IS: 1786, IS: 226, IS: 432 as the case may be in respect of physical properties, chemical requirements tolerance limits etc.

All steel reinforcement and wire, nails etc, required for the works shall be supplied by the contractors who shall make their own arrangements for the procurement of reinforcement bars from the open market.

4.0 BRICK MASONRY WORKS:

4.1 Materials:

- (1) Bricks: brick to be sound, well burnt, free from cracks, to ring when struck and not to crack or break when soaked in water or thrown on the ground on their flat face from a height of 60 cm, or when soaked in water in a saturated condition, regular in shape and uniform in size. They shall be of the best description obtainable in market and of the best quality and colour. They shall not absorb water more than 20 percent dry weight, when immersed in water for 24 hours. They shall have a crushing strength of not less than 35 kg / sq.cm.
- (2) Sand: sand shall conform to the specifications detailed already for sand.

4.2 Cement Mortar:

All cement mortar to be used on this work shall be in proportion as specified and directed by the Engineer. The ingredients shall be in proportion as specified and directed by the Engineer. The ingredients shall be measured dry, by means of properly made gauge boxes on a covered platform and shall be thoroughly mixed dry before adding water to get the required consistency. Only such quantity of mortar shall be prepared at a time as can be used up immediately. Mortar after it has begun to set shall not be allowed to be raked up again, but shall be rejected and the contractor shall remove the same from the work site immediately.

4.3 Workmanship:

The work of brick shall be carried out in a workman like manner and in a perfect plumb, line and level as required. Brick shall be thoroughly cleaned well watered or soaked in water for at least 12 hours before being used on the work. No broken bricks shall be preserved throughout the work both laterally and transversely. All bed joints shall be horizontal in vertical walls, radial in arches and at right angle for the slopes in battered wells. In walling, the courses shall be kept perfectly horizontal and rise in plumb. The vertical joints shall break joints with the courses below and above. Use of bats shall be avoided as far as possible. The joints shall be close and regular and shall not exceed 12mm in thickness. The bond shall be English bond unless otherwise permitted by the Engineer. The contractors shall provide at their own expense all moulds, templates, centers, scaffolding etc. as may be required for the proper execution of the work and nothing extra will be paid for the same including dewatering where necessary.

The mortar used should be stiff. The brick work shall be kept wet while the work is in progress for at least seven days after completion, to the entire satisfaction of the Engineer. On Sundays and holidays when the work is not in progress, the masonry shall be watered continuously by engaging Bhisties. Watering shall be done carefully so as not to wash out the mortar of the joints. The Engineer shall be at liberty to engage Labours at contractor's cost to water/curing. If contractors fail to do so, the work shall be pulled down and rebuilt at the risk and cost of the contractors.

The whole of the masonry work shall be carried up at one uniform level through out but where breaks are unavoidable, the joint shall be made in good long steps raked so as to prevent cracks arising due to separation of old and new work. All junctions of walls shall be formed at the time the walls are being built and cross wells shall be carefully bonded into the main walls.

When the work is to be added to existing structure, the old work must be prepared to receive new work by roughening and grouting with a layer of rich mortar and both must be carefully bonded together.

During rains, the works to be carefully covered without extra charge so as to avoid fresh mortar being washed away.

4.4 Cement plaster:

Cement plaster shall be provided to brick masonry or rubble masonry wherever directed by the Engineer.

(a) Materials:

(1) Cement: cement shall conform to the specifications detailed earlier.

(2) Sand: sand shall conform to the specifications detailed earlier.

(b) Cement Mortar: All cement mortar to be used on this work shall be in proportion as specified in the drawings and as directed. The ingredients shall be measured dry, by volume of properly made gauge boxes, on a covered platform and shall be thoroughly mixed dry before adding water to get the required consistency. Only such quantity of mortar shall be prepared at a time as can be used up immediately. Mortar after it has begun to set shall not be allowed to raked up again, but shall be removed from the work immediately. Cement mortar shall be used within 30 minutes after it leaves the mixing Corporation or mill.

(c) Workmanship: - All bricks shall be thoroughly wetted, joints and raked and well washed.

4.5 Pointing:

The whole of the exposed faces of the brick work, out stone work and stone paving when described as to be pointed are to have the joint raked out to a depth of 13 mm and pointed with cement and sand (unless otherwise described) in the proportion of one of cement to one of fine sand flush with the face of the work and out straight, parallel and of uniform width.

The exposed faces of the rubble-work are to be similarly pointed (when described as to be pointed) but the joints shall be raked out to a depth of 20mm and shall be raked out to a depth of 20mm and shall be irregular in direction. The above description of pointing shall apply generally so all classes except only as the pointing materials which may in certain cases or otherwise described in this specification.

4.6 Protection of work from sun:

All cement work pointing, plastering and concreting shall be protected from the sun and the surface kept moisture until in the opinion of the Engineer-in-charge it is thoroughly set.

5. DEFINITION OF INCOMPLETE WORK:-

A line or trench of sewer pipeline (including the excavation thereof and all other accessories thereto) will be considered incomplete unless entirely laid, jointed and fully tested, encased wherever required the trench filled and consolidated and the manhole at each and completely finished with floors, channels, cover and all other detail. A manhole will be considered complete unless it is completely finished as above and at least one of the lines of pipe sewer to which it belongs or is attached is complete as described above.

The contractor shall have no claim for incomplete work and no incomplete work will be measured up for payment to the contractors.

5.1 Rates quoted in Bill of Quantities to cover everything necessary for complete Execution of work:-

The rates quoted will be held to cover everything necessary of the due and complete execution of the work according to the drawings and the several conditions and the stipulations of the contract, including specification, or the evident intent and meaning of all or either of them or according to customary usage and for the periodical and final inspection and test and proof of the work in every respect and for measuring, numbering or weighing the same including setting out and laying or fixing in position and the provision of all materials, power, tool rammers, beaters, labour, tackle platforms with impervious lapped joints for scaffolding ranging rods, straight edges, centering and boxes, wedges, moulds, templates, post straight rails, boning-staves, measuring rods, page boards, shores, barriers, fencing, lighting, pumping apparatus, temporary arrangements of passage of traffic, access to premises and continuance of drainage, water supply and lighting (if interrupted by the work) lard temporary sheds and buildings nahanis roofed in or otherwise haulage, painting, varnishing, polishing, establishments for efficient supervision and watching arrangements for the efficient protection of life and property and all requisite plant, implements and appliances every kind, except only such matter and things as it may be distinctly stated here in are to be supplied by the contractors. A rate for anyone description of work is to be held to include such items of other classes of and for these on separate specific charge will be admitted. The contractors shall keep every portion of the work clear of accumulation from time to time and shall leave every portion of the work clean, clear, perfect and at the conclusion of whole, providing at their own cost all such material implement appliances and labour as the Engineer may require to prove if it is to be so.

6. CONTRACTOR TO OBSERVE ALL CONDITIONS:

The contractors are particularly directed to observe from the Articles of Agreement and the specifications, what is to be included in their rates for the several portions of the work and also under what conditions payments are to be made.

Asst. Engineer
R.M.C.

Dy. Ex. Engineer
R.M.C.

City Engineer
R.M.C.

Signature of Contractor.

D. ADDITIONAL CONDITIONS

D. ADDITIONAL CONDITIONS:

1. The contractor shall have to provide his own level instrument for this work.
2. Lowering, laying and jointing works of all the pipelines shall have to be carried out by using Sight Rails and Boring Staves.
3. Work is required to be carried out in residential area where all the services like water supply, sullage water pipeline, telephone / electric cable are existing. Under the circumstances, prior to starting the work agency shall have to excavate the trenches manually for up to 1 mt. depth. During the course of execution, all the services shall have to be maintained by the agency and any damage to any services or property, the agency shall have to get it repair at their cost.
4. For excavation of trench, use of JCB machine will not be permitted directly on the top surface of the road. After excavation up to minimum 1.00 mt. depth from road surface or existing ground level, same shall have to be carried out manually or by using Breaker and after locating underground services like; water supply pipeline, water connection lines, pipe gutters, telephone cables, electric cables etc., and thereafter upon taking the prior approval of the Engineer-In-Charge, the excavation can be carried out by using JCB machine.
5. Rajkot Municipal Corporation shall recommend to the competent authority to give Controlled Blasting License to the contractor for carrying out excavation in hard rock. In case of blasting license not permissible from the competent authority in some places then excavation is to be done by using wedges and hammers, chiseling, breakers, pneumatic tools, etc. Also in case where blasting license is permitted but even then if there is no possibility of carrying out the blasting for whatsoever reason, the excavation is to be done by using Wedges and hammers, chiseling, breakers, pneumatic tools etc. No extra payment shall be made for excavation to be carried out in any of the above mentioned both the situations.
6. Excavation in soft rock and hard rock shall have to be carried out only by Chiseling, Breaker (pneumatic tools) etc., as far as possible. If excavation is not possible in terms of above and if excavation is required to be carried out with the help of blasting then the same shall have to be carried out only after taking prior approval and necessary license for blasting from the competent authority.
7. In case of excavation not possible manually or by chiseling in certain place(s) as well as if blasting is also not possible due to various reasons i.e. to avoid damage to nearby water pipeline, pipe gutter, telephone cables / Duct, Raw houses / week buildings / narrow street etc., then the excavation by blasting will not be permitted. Under these circumstances, excavation shall have to be carried out only by Breaker (pneumatic tools) as per the instructions of the Engineer-In-Charge. No extra payment will be made for such type of excavation done by using Breaker. The rate for excavation shall be paid as per the rate of related item mentioned in Schedule-B.
8. The safety of the trenches is the prime important factor. Along the trenches on both the side, a hump of excavated stuff of minimum height 3 to 5 ft shall have to be provided till the work is got completed. However, where there is

no defined road, in such area, the fencing/ lighting etc., requires to be provided as per clause 1.1.15. Sign Board shall have to be provided at required locations, so that there will not be any fatal accident.

9. Regarding the width of excavation, as (a) it is difficult to carry out the vertical trench excavation, (b) possibility of sliding the soil, and (c) uneven excavation trench width in case of blasting. In this connection, for every 1.5 mt lift if there is less width upto 5 cm at the bottom then the top width of excavated trench, it shall be considered as per the specified trench width or actual trench width carried out at the ground level by the contractor whichever is less. If excavation is carried out more than the specified width then the payment will be made only for the specified width of excavation.
 in all normal conditions, the width shall be kept as mentioned in the Tender Drawing No.12 (Normal Condition). Under specific circumstances, additional width, if required, as per the opinion of the engineer-in-charge in the interest of work, the contractor shall be permitted with prior approval from engineer-in-charge to carry out such excavation work by keeping the width as mentioned in the Tender Drawing No.12 (Specific Condition). For mode of measurement for excavation, the width of excavation will be considered as given at the time of line out by engineer-in-charge or actual width done whichever is less.
10. The pipes shall be with ISI mark whereas that of manhole frame and cover shall be confirming to relevant IS. The pipes and manhole frames & covers shall be inspected by competent authority of RMC / approved TPI Agency.
11. After entering into an agreement, the agency shall have to finalize the agency for supply of the material like pipes, manhole / house connection chamber frame and covers etc., and the name of manufacturer / supplier should immediately be informed to Rajkot Municipal Corporation so that Rajkot Municipal Corporation can also expedite the manufacturer / supplier for the material. If necessary, Rajkot Municipal Corporation will visit and inspect the factory. During the inspection, if Rajkot Municipal Corporation is not satisfied then the contractor shall have to procure the material from other manufacturer(s).
12. While the work in progress, there is possibility of change in drainage line routes according to the site conditions. Under these circumstances, the contractor shall have to carry out the work accordingly, for which, no extra payment shall be made in such situations. Over and above, the decision of Engineer-in-charge for change in drainage line routes shall be final and binding to the contractor.
13. The quantity of various items mentioned in the schedule-B is liable to increase or decrease up to any extent. Under the circumstances, the contractor shall have to carry out the work accordingly without any rate escalation. Rajkot Municipal Corporation will not entertain any dispute in this regard.
14. In excavation, the decision regarding classification of strata shall rest with the Engineer-In-Charge and his decision in this regards shall be final and binding to the Contractor.
15. The rates are inclusive of dewatering, if required.
16. Regarding water supply for flow testing necessary water, power, labour etc. required for the necessary test shall be arranged by the contractor at his own cost.
17. During Construction Activity proper care must be taken for labour safety and must follow the provision of the labour law.

18. Testing of the all required materials like Bricks, Sand, Aggregate etc. should have to be tested periodically as suggested by the Engineer-in-charge at government approved material testing laboratory and testing charges for the same has to be born by the contract agency.
19. In case of any ambiguity found in specifications / drawings etc, the decision of engineer-in-charge shall be final and binding to the contractor.
20. Regarding Testing & Testing charges of the materials it is clarified that R.C.C. pipes, Stone ware pipes and Manhole frame & Cover are to be tested as per IS requirement as mentioned in the tender documents by approved TPI/PMC Agency.
21. The word "Arbitration" or "Arbitration Clause" wherever mentioned in this tender document, is now to be treated as "Deleted". In this context, an Order bearing No.RMC/Legal/1858 dated 18-02-2017 of Legal Department of Rajkot Municipal Corporation is uploaded separately along with this tender, which Order, will hereafter be referred and taken into consideration for Arbitration related purpose for the tenders of Rajkot Municipal Corporation.
22. The whole work is to be carried out and executed with utmost care by taking all necessary safety precautions as it is to be done in residential area and on main roads with heavy vehicular traffic, failing which, it will be the whole responsibility of the agency.

Asst.Engineer
R.M.C.

Dy.Ex. Engineer
R.M.C.

City Engineer
R.M.C.

Signature of Contractor.

SECTION - 4
SCHEDULE OF DRAWING

SECTION - 4
SCHEDULE OF DRAWING

Sr No	Drawing No	Details	Page No.
1	3	Manhole Type A-1	T T A C H E D I N S E P A R A T E
2	4	Manhole Type A	
3	5	Manhole Type B	
4	6	Excavation Standard Width of trench	
5	8	Typical RCC pre-cast frame & cover	
6	13	Bedding Detail (C.C Bedding)	
7	14	Bedding Detail (sand/Granular bedding)	

PART-III
BILL OF QUANTITIES

Price Schedule

(Price Bid)

PART-III**Price Schedule - B
(Price Bid)**

Name of work :-	Providing, Lowering, Laying, Jointing and Testing Work of 600 mm dia NP3 class pipe and manhole work for Sewage house Connection system Under Rajkot Underground Sewerage work near Kalawad Road Drainage Pumping Station in Ward No.10
------------------------	---

Sr. No.	Quantity	Short Description of Item	Rate	Unit	Amount
1	1110.00	Excavation work soft murrum / hard murrum average rate upto 1.50 mt depth	100.05	Cu.M	111055.50
2	395.00	Excavation work soft rock / hard rock average rate upto 1.50 mt depth	369.15	Cu.M	145814.25
3	395.00	Excavation work soft murrum / hard murrum average rate upto 1.51 to 3.00 mt depth	393.30	Cu.M	155353.50
4	395.00	Excavation of Foundation in Hard Rock with Breaker / Blasting / Gann from 1.51 mtr. to 3.0 mtr depth including lifting and laying in 90 mtr.	531.30	Cu.M	209863.50
5	198.00	Excavation of Foundation in Hard Rock with Breaker / Blasting / Gann from 3.01 mtr. to 4.50 mtr depth including lifting and laying in 90 mtr.	552.00	Cu.M	109296.00
6	222.00	Supply and necessary line level and laying in grade, jointing etc. complete etc. of RCC Spun pipe having ISI Mark NP3 Class pipe standard length of dia. as given below of spigot and socket with rubber ring including all taxes, insurance, transportation, loading, unloading at destination Store or site including necessary inspection 600 mm dia NP3 Class pipe	2418.00	R.Mt	536796.00
7	36.00	Hard murrum with supply and spreading etc complete..	263.00	R.Mt	9468.00
8	5.00	B Type Manhole work for drainage	12589.00	No.	62945.00
9	3.00	B Type Manhole work for drainage additional depth	9934.00	No.	29802.00
10	5.00	Supply and fixing of 20 T round Precast frame cover paid	2306.00	R.Mt	11530.00
11	1440.00	Lifting of soil with spreading at designated place as directed by engineer in charge	122.00	No.	175680.00
12	3.00	Making hole in wall with repairing work complete	75.00	No.	225.00
Total					1557828.75
Say					1558000.00

Asst.Engineer
R.M.C.

Dy.Ex. Engineer
R.M.C.

City Engineer
R.M.C.

I/We agree to carry out the above said work at ____% (In Figure) _____
(In Words) Above / Equal / Below on the tendered rates shown in Scheduled-B.

Note: Contractor shall have to quote their rates online only. Rates received in any other format will not be acceptable.

Signature of Contractor

BID FORM(WITH PRICE)

Bidders are required to fill up all blank spaces in this Bid Form

The Commissioner
Rajkot Municipal Corporation
Dr. Ambedkar Bhavan
Dhebar Road
Rajkot

Dear Sir,

SUB : **BID DOCUMENT FOR** Providing, Lowering, Laying, Jointing and Testing Work of 600 mm dia NP3 class pipe and manhole work for Sewage house Connection system Under Rajkot Underground Sewerage work near Kalawad Road Drainage Pumping Station in Ward No.10

Having visited the site and examined the Bid Documents, Drawings, Conditions of Contract, Specifications, Schedules, Annexures, Preamble to Price Schedules, Price Schedules etc. including Addenda/Amendments to the above, for the execution of the above Contract, we the undersigned offer to carry out providing underground sewerage system under Rajkot Underground Sewerage Project Phase-II Part-II as given in Conditions of Contract and in conformity with the Drawings, Conditions of Contract, Specifications, Preamble to Price Schedules, Price Schedules, Annexures, Bidding Documents, including Addenda Nos. _____ (insert numbers) for _____ %age (in figure) _____ (in words) below / above than the rates given in Price Schedule.

2. I / We agree that

- (a) if we fail to provide required facilities to the Employer's representative or any other person/agency by the employer to perform on his behalf for carrying out the inspection and testing of materials and workmanship
or
- (b) if we incorporate into the Works, materials before they are tested and approved by the Engineer's representative
or
- (c) if we fail to deliver raw water of required quantity according to the conditions/stipulations of the Contract, the Engineer will be at liberty to take any action including termination of Contract and impose at his absolute discretion any penalties, and/or reject the work.

3. We undertake, if our Bid is accepted, to complete and deliver the Works in accordance with the Contract as prescribed in tender document, exclusive of monsoons, from the date of Work Order issued to us by you.

4. We agree to abide by this Bid for a period of 180 days from the date fixed for receiving the same and it shall remain binding upon us and may be accepted at any time before the expiry of that period.
5. In the event of our Bid being accepted, we agree to enter into a formal Contract Agreement with you incorporating the conditions of Contract thereto annexed but until such agreement is prepared this Bid together with your written acceptance thereof shall constitute a binding Contract between us.
6. We agree, if our Bid is accepted, to furnish Performance Bond/Security in the forms and of value specified in the Conditions of Contract of a sum equivalent to 5% of the Contract price for due performance of the Contract.
7. We have independently considered the amounts of liquidated damages shown in Appendix to Bid and agree that they represent a fair estimate of the damages likely to be suffered by you in the event of the Work not being completed by us in time.
8. We understand that you are not bound to accept the lowest or any Bid you may receive.

Date this _____ day of _____ 2020.

(Signature)

(Name of the person)

(In the capacity of)

Company Seal

(Name of firm)

Duly authorized to sign Bid for and on behalf of
(Fill in block capitals)

Witness

Signature _____
Name _____
Address _____

PREAMBLE TO PRICE SCHEDULE

Note on Schedule

1. The bid is percentage rate bid for procurement, construction, testing, commissioning, the underground drainage system under PPP.
2. The whole work is to be done under the supervision of RMC.
3. Before starting the work, the details survey has to be done by the contractor and shall have to prepare and submit Survey and Level drawings in soft copy (Auto Cad) and Hard copy, and has to mark permanent levels at all necessary locations for Reference, for which, no extra payment will be made by Rajkot Municipal Corporation. After permission / approval from the engineering in charge, the work will have to be executed accordingly on site.
4. The rates and prices shall be submitted in the formats given in the enclosed Price Schedules. Rates and prices received in any other formats will be rejected and the Bids will be disqualified.
5. It will be entirely at the discretion of the Employer to accept or reject the bidder's proposal, without giving any reasons whatsoever.
6. In Price Schedule, bidder shall quote his percentage Equal/Above/Below for items listed in the schedule. Prices quoted in Schedule only will be considered for price evaluation & shall form a part of the Contract Agreement.
7. Only Price Schedule will be considered for financial evaluation of the bid with the successful bidder.
8. The bidder shall be deemed to have allowed in his price for provision, maintenance and final removal of all temporary works of whatsoever nature required for construction including temporary bunds, diverting water, pumping, dewatering etc. for the proper execution of works. The rates shall also be deemed to include any works and setting out that may be required to be carried out for laying out of all the works involved.
9. Where there is a discrepancy between the unit rates and the amount entered, in the price schedule the latter shall govern.
10. The Price Schedules are to be read in conjunction with the Conditions of Contract, the Specifications and other sections of these bid documents and these documents are to be taken as mutually explanatory of one another.
11. Prices quoted by the bidder shall be firm for the entire period of Contract without any escalation.
12. The bidder shall interpret the data furnished and carry out any additional survey work, or investigation work required at his own cost.
13. The prices quoted shall also include the cost of materials utilized for testing.
14. The bidder should acquaint himself with the site conditions including the access to Worksite. The successful bidder shall have to make suitable access to worksites at his own cost. These accesses will be used by the other contractors working for RMC.
15. From each Running Account Bill, labour cess will be deducted as per norms.
16. The quoted rates should be inclusive of all taxes and duties.
17. The prices shall have to be quoted firm & fix including all the taxes & duties without any statutory variation. RMC will not consider any statutory variation as well as the price rise in the market and if any, those shall be on account of contractor

18. The work contract tax will be borne by the agency.
19. While considering experience of ongoing sewer/storm water pipeline works, part work completed in all respect will be considered for evaluation of bid. In this regard contractor shall be required to submit part completion certificate along with bid document from the competent authority.
20. Use of ready mix concrete may be permitted if it fulfils tender specifications.
21. No extra item or extra width will be paid due to excavating method or type of machinery.
22. Appendix - P mentioned in tender is a sample format. The bidder shall furnish the details of concern tender and financial terms shall be certified by Chartered Accountant.
23. In Every running bill 0.25% amount shall be retained as extra security deposit If Drawings of work done are not submitted by agency.
24. As Road Restraining is the responsibility of work contract agency, in Every running bill 0.50% amount shall be retained as extra security deposit for purpose of Corrections for road restraining in case of settlement of surfaces of refilled trenches. These shall be released Defect Liability Period.
25. For any type of license regarding labour etc. has to be achieved by agency
26. This office Circular bearing No. RMC/C/329 dated 22-12-2012 and Order No. RMC/C/132 dated 10-06-2013 are uploaded in tender document. The Contractors quoting their rates shall have to read, implement, and submit the same duly signed along with the documents to be submitted during physical submission.
27. In reference to the above Circular and Order cited at above, the Contractor firm who have quoted their rates for this work will be called in person for verification of original documents. The date and time for verification of original documents will be intimated to the Contractors.
28. The routes and levels shown in the maps are indicative and not final. There are possibilities of change in routes and levels at the time of execution of work and due to which the diameter of pipeline and depth of drainage line may increase or decrease. Under the circumstances, the contractor shall have to carry out the work accordingly at the approved rates without any extra cost. Rajkot Municipal Corporation will not entertain any dispute in this regard.
29. The contractor shall have to carry out the sub-soil strata investigation at his own cost.
30. Flow Test shall be done in two stage
Stage 1.
Pipe line shall be laid by resting the pipe line on supports at joints. The flow test and The drains, manholes and all joints of pipes shall be made thoroughly sound and water tight and any joint which may be observed to be leaky shall be immediately corrected. Thus after satisfactory flow test sand bedding shall be fill pipe line after laying pipe line. The refilling of trench shall be carried out then after
Stage 2.
After total laying & refilling of trenches, flow test shall be carried out again for particular section of length as suggested by engineer in charge.
31. If the progress of work is found slow then Extra Security Deposit may be recovered from any running bill as decided by Engineer in charge up to maximum 5% amount of concerned R.A. Bill amount.
32. Payment shall only be done in case of complete section. Complete section - It is the length of laid Pipe part of the Work where Manhole or House Connection Chamber work on both ends of line is complete, manhole frame cover placed and the same is backfilling as per tender norms be completed and the surface has been finished by proper compaction as per tender norms and / or as per instruction of engineer in-charge.

33. Payment shall only be done in case of complete section. Complete section - It is the length of laid Pipe part of the work where sand bedding has been done and the same be backfilled as per tender norms be completed and the surface has been finished by proper compaction as per tender norms and / or as per instruction of engineer in-charge.
34. Wherever the sanction of Forest and State High Way (R & B) department is required that has to be procured and also any other sanction of any other Institute/Authority is required then contracting agency shall have to arrange itself i.e. whole liaison shall be on account of working agency. However, if required, RMC will recommend for the same wherever necessary. The expenditure incurred for this type sanctions will be reimbursed by RMC on submission of necessary documentary evidence like; Receipt, as proof.
35. Blasting may not be permitted in the areas having dense population or any other unsuitability.
36. Big machinery may not enter in the areas having narrow streets (3 to 4 Mtr. wide).
37. Kachcha houses shall not be get damaged. Considering this, manual labour work will be more feasible.
38. No extra item or extra width will be paid due to excavating method or type of machinery.
39. The tenders are advised to visit the project area and get acquainted with the local condition as the said area is residential area with numbers of underground utility services like water supply pipe line, sullage water pipe line, gas pipe line, telephone/electric cable, KHALKUVAS etc. which requires to be maintained during the progress of work. The safety of the work is prime important factor and all the tenderer should be very much vigilant for the same. Thus, there may be some locations where clear ROW or ROU may not be available due to certain reasons like TP Road open Issues, Permissions etc. If work of that much location is affected due to such reasons time limit may be extended considering that non-working period but in no case Price Escalation will be given for that extended period.
Thus, it is to be clear that to work within utility services is a part of this work. If utilities are affected, it shall be the responsibility of tenderer to make same as it was as before. The expenditure and arrangement shall be bear by Tenderer.
40. Temporary drainage work like temporary diversion of gutter line, khal kuvas or bailing work of sub soil water, diversion of storm water way etc., is to be carried out by contractor without any extra claim. Cost towards shifting, repairing, replaced of utilities to be borne by Tenderer.
41. Appendix - P mentioned in tender is a sample format. The bidder shall furnish the details of concern tender duly signed by Chartered Accountant and Tenderer. Ongoing Work list (i.e. Running Work details) must be attached.
42. In case of Extra Item, No on % age i.e. +ve % age Rate will be given but if there is Down % age i.e. -ve % age Rate that will be applied to that rate of that Extra Item.
43. Before procurement of Material the Quality Assurance Plan (QAP) shall be approved by RMC. QAP for approval shall be submitted in 3 Original copy duly signed and stamped by Manufacturer, TPI/PMC and Tenderer. The draft QAP has been attached herewith.
44. QAP of Stoneware / RCC /GRP pipe to be approved by TPI/PMC Agency
45. The contractor shall have to quote their rates including GST and other taxes and the Invoice with break-up of GST is to be submitted accordingly, failing which, such amount will be deducted from the bill of the agency and deposited accordingly.

The contractor shall have to purchase the material required for this tender work, only from the supplier having registered GST Number. RMC will not be responsible to pay any amount towards GST if the material is purchased from the unregistered supplier / not having GST Number.

46. The contractor shall be responsible for Railway Crossing, Highway crossing etc and the detailed design shall have to be provided by the contractor and carry out the same, for which, payment will be made as per norms.
47. The contractor shall have to obtain the approval from the concerned authorities for level crossing, Highway, Gas etc. However, Rajkot Municipal Corporation will extend its cooperation in obtaining the approval. The charges as per norms shall be paid by the agency and same will be reimbursed by Rajkot Municipal Corporation.
48. In case of extra item work if quoted and approved tender price is above Percentage Rate then no above percentage rate will be given, only the rates as per S.O.R. will be paid for such extra item. But, if the quoted and approved tender price is below percentage rate then that below percentage rate will be considered for paying of any extra item

Asst. Engineer
R.M.C.

Dy.Ex. Engineer
R.M.C.

City Engineer
R.M.C.

Signature of Contractor.