

RAJKOT MUNICIPAL CORPORATION

e - Tender No. RMC/ENGG/CZ/24-25/7-6



Azadi@75
स्वच्छ
सर्वेक्षण
#MeraShahar, MeriPehchan 2023

Bid Documents For

(A) RENNOVATION WORK OF AVANTI BAI LODHI COMMUNITY HALL

(B) CONSTRUCTION OF SECURITY QUARTER AND STAFF OFFICE IN SIXAN SAMITI OFFICE CAMPUS

(C) RENNOVATION OF WARD OFFICE-7C ON BHUPENDRA ROAD & WARD OFFICE 7-D HATHI KHANA IN WARD NO.-7

Milestone dates for e-tendering is as under

1. Downloading of e-documents	29-11-24 To 23-12-24 upto 17.00 Hrs.
2. Pre-bid meeting in the Engineer at CENTRAL ZONE	04-12-24 at 11:00 Hrs
3. Last date for online submission of e - Tender	23-12-24 upto 18.00 Hrs.
4. Submission of EMD, Tender fee and other documents for verification by Regd. Post.A.D. / Speed Post	26-12-24 upto 18.00 Hrs.
5. Opening of Technical Bid	27-12-24 at 11.00 Hrs. onwards
6. Verification of submitted documents (EMD, e - Tender fee, etc.)	30-12-24 at 11.00 Hrs. onwards
7. Agency to remain present with original documents for verification	31-12-24 between 16.00 to 17.00 Hrs.
8. Opening of Price Bid (For Technically qualified bidders only)	02-01-25 at 11.00 Hrs. onwards
9. Bid Validity	120 Days

2024-25

ADDL. CITY ENGINEER
RAJKOT MUNICIPAL CORPORATION
DR. AMBEDKAR BHAWAN
CENTRAL ZONE, DHEBARBHAI ROAD,
RAJKOT - 360001 (GUJARAT)

RAJKOT MUNICIPAL CORPORATION

BID DOCUMENT FOR

- (A) RENNOVATION WORK OF AVANTIBAI LODHI COMMUNITY HALL
(B) CONSTRUCTION OF SECURITY QUARTER AND STAFF OFFICE IN SIXAN SAMITI OFFICE CAMPUS
(C) RENNOVATION OF WARD OFFICE-7C ON BHUPENDRA ROAD & WARD OFFICE 7-D HATHIKHANA IN WARD NO.-7

PART-I

Section-1 Invitation to Bid, Instructions to Bidders and Formats.

Section-2 General Conditions of Contract

PART-II

Section-3 Technical Specifications

PART-III

Bill of Quantities (With Price)

ABBREVIATIONS

Statement showing the details of abbreviations

Full Form	Abbreviation
ADDL. CITY ENGINEER	ACE
Operation and Maintenance	O&M
Net Present Value	NPV
Engineering Procurement and Construction	EPC
Paschim Gujarat Vij Co. Ltd.	PGVCL
Critical Path Method	CPM
Reinforced Cement Concrete	RCC
High Ground Level Reservoir	HGLR
Kilometer	KM
Mild Steel	MS
Bureau of Indian Standard	BIS
American Water Works Association	AWWA
American Petroleum Industries	API
Million Liter per Day	MLD
High Yield Strength Deformed bar	HYSD
Corrosion Resistance Steel	CRS
Ordinary Portland Cement	OPC
American Standard for Testing of Material	ASTM
Flux Compensated Magnetic Amplifier	FCMA
Cost Insurance and Freight	CIF
Free On Board	FOB
EX – Works	EXW

PART - I
SECTION - 1

INVITATION FOR BIDS

RAJKOT MUNICIPAL CORPORATION

e- TENDER NOTICE

The e-Tenders are invited with two bid system by e-Tendering from the experienced contractors registered in GWSSB / State Government / Central Government / Semi Government in appropriate class for below mentioned work:

SrNo	Name of work	a) Estimated cost in Rs. b) EMD c) E-TENDER fee d) Time limit for completion of work
1	(A) RENNOVATION WORK OF AVANTIBAI LODHI COMMUNITY HALL (B) CONSTRUCTION OF SECURITY QUARTER AND STAFF OFFICE IN SIXAN SAMITI OFFICE CAMPUS(C) RENNOVATION OF WARD OFFICE-7C ON BHUPENDRA ROAD & WARD OFFICE 7-D HATHIKHANA IN WARD NO.-7 e-TENDER No. RMC/ENGG/CZ/24-25/7-6	a1) Rs.52,22,000/- With GST a2) Rs.44,25,000/- Without GST b) Rs.44,250/- c) Rs.1875/- d) 9 months

Milestone dates for e-tendering is as under	
1. Downloading of e-documents	29-11-24 To 23-12-24 upto 17.00 Hrs.
2. Pre-bid meeting in the Engineer at CENTRAL ZONE	04-12-24 at 11:00 Hrs
3. Last date for online submission of e - Tender	23-12-24 upto 18.00 Hrs.
4. Submission of EMD, Tender fee and other documents for verification by Regd. Post.A.D. / Speed Post	26-12-24 upto 18.00 Hrs.
5. Opening of Technical Bid	27-12-24 at 11.00 Hrs. onwards
6. Verification of submitted documents (EMD, e - Tender fee, etc.)	30-12-24 at 11.00 Hrs. onwards
7. Agency to remain present with original documents for verification	31-12-24 between 16.00 to 17.00 Hrs.
8. Opening of Price Bid (For Technically qualified bidders only)	02-01-25 at 11.00 Hrs. onwards
9. Bid Validity	120 Days

1. The e-tender fee will be accepted only in form of Demand Draft in favor of "Rajkot Municipal Corporation "Rajkot, payable at Rajkot from any Nationalized Bank or Scheduled Bank (except Co-operative Bank) in India and must be delivered to above address.
2. All bidders must submit Bid security(EMD)as above either directly deposited in ICICI Bank Account No.015305010638 (Rajkot Municipal Corporation) IFSC Code ICIC0000153 or submit at the below mentioned address in form of Demand Draft in favour of "Rajkot Municipal Corporation", Rajkot, from any Nationalized Bank or Scheduled Bank (except Co-operative Bank) in India. Bank Guarantee will also be accepted.

3. Submission of required documents shall have to be done at the below mentioned address:

Office of the ADDL. CITY ENGINEER
Rajkot Municipal Corporation,
DR. AMBEDKAR BHAWAN,
CENTRAL ZONE Office,
DHEBARBHAI ROAD,
Rajkot-360001 (Gujarat)

4. The prequalification requirement is as under:

1. Financial Criteria:
2. The Bidder must have achieved a minimum annual turnover in anyone year over the last seven financial years of the annual value of contracts value.
3. The Bidder should give undertaking that he has access to or has available, liquid assets and/or credit facility equal to 25% of the value of the contract / contracts applied.
4. Available Bid Capacity (ABC) must be more than the estimated tender cost.

Available bid capacity (ABC) = (Ax N x 2)–B, where,

A = Maximum of updated total amount of work executed in any one year of the last seven financial years.

B = Amount of the existing commitments and ongoing works to be discharge during time interval of N years from the bid due date.

N = Number of years prescribed for completion of the proposed works

5. Bidder must have minimum "E1" Class registration.

ii) Experience Criteria:

The bidder should possess following minimum experience :

- 1 Bidder should have completed OR substantially completed at least one work of 40% of tender amount either in Government or Semi-Government or Government Autonomous Body as a main contractor in period of last seven years.

Note:

- i) Substantially completed works means those works which are completed at least 90% of original contract price on the date of submission of this tender and execution is satisfactory.
 - ii) The work may have been executed by the applicant as prime contractor or as a member of a joint venture. In case a project has been executed as a joint venture, joint venture proportion will be taken into consideration.
- 2 Bidder should have enough machinery and experienced personnel to supervise the work.

Note: Enhancement factor at 10 % per year will be applicable to arrive at average annual turnover and finalize the magnitude of work done in last seven years.

Sr	Year	Enhance factor
1	Current Year (2024-25)	1.00
2	Current Year - 1 (2023-24)	1.10
3	Current Year - 2 (2022-23)	1.21
4	Current Year - 3 (2021-22)	1.33
5	Current Year - 4 (2020-21)	1.46
6	Current Year - 5 (2019-20)	1.61
7	Current Year - 6 (2018-19)	1.77
8	Current Year - 7 (2017-18)	1.95

- 3 For Financial and Experience criteria, the estimated cost of Rs. 44,25,000/- will be considered.
5. Bidder has to quote their rates without GST and including other taxes. The invoice should be submitted by contractor showing the breakup of GST in the bill. GST will be paid extra at the prevailing rate at the time of execution.
6. The contractor shall have to purchase the material required for this tender work, only from the supplier having registered GST Number. RMC will not be responsible to pay any amount towards GST if the material is purchased from the unregistered supplier / not having GST Number.
7. After opening of Technical Bid, the procedure for the pre-qualification shall be adopted and the Price Bid of only successful qualified bidder shall be opened for final evaluation of the contract. The decision of Municipal Commissioner regarding the pre-qualification shall be final and binding to all the bidders.
8. The Tender of those bidder(s) those who fails to produce the required documents physically within the stipulated date and time, will be treated as non responsive and their Price Bid will not be opened.
9. The bidder should not have been Black Listed, suspended, terminated, backed out, debarred & delisted by any Municipal Body / Urban Local Body / Development Authority in any State Government Body or undertaking / any department or undertaking of Government of India, since inception of the firm /Company. Such a case will be rejected out rightly. A Declaration in this regard on Rs.300/- Stamp Paper duly Notarized shall have to be submitted as per Annexure along with the tender documents. Submission of the bid document without such Notarized declaration will be rejected out rightly.
10. The bidder should provide accurate information on any litigation history or arbitration resulting from contracts completed or under execution by him over the last ten years. This should also include such cases, which are in process / progress. A consistent history of awards against the bidder may result in failure of the bid. In case the bidder has not provided such information and has come to the notice of the authority, the tender will be rejected at what so ever stage and in such case all the losses that will arise out of this issue will be recovered from the Bidder/bidder and he will not have any defense for the same.

11. Joint Venture is not permitted for this tender.
12. Conditional Tenders will be out rightly rejected.
13. If no agency remains present and are no points for Pre bid meeting, "NIL" minutes to be considered and the same will not be uploaded.
14. Rajkot Municipal Corporation, Rajkot, reserves the right to accept/reject any or all e-tender(s) without assigning any reasons thereof.

ADDL. CITY ENGINEER
Rajkot Municipal Corporation

CHECK LIST FOR SUBMISSION OF DOCUMENTS (ONLINE AND OFFLINE)

The bidder must submit the relevant documents as per below:

Sr No	Document Name	ONLINE SUBMISSION	OFFLINE SUBMISSION
1	Tender Fee	✓	✓
2	EMD	✓	✓
3	Tender Documents with Corrigendum, if any	✓	--
4	Agency Registration Certificate	✓	--
5	GST Registration	✓	--
6	PAN Card	✓	--
7	PF Registration	✓	--
8	ESIC Registration	✓	--
9	Labour License & CESS Registration	✓	--
10	Profession Tax(PEC and PRC)	✓	--
11	Solvency Certificate	✓	--
12	Non-Blacklist Declaration	✓	--
13	Turnover Certificate from CA	✓	--
14	Work Experience Certificates	✓	--
15	Other documents, if any	✓	--

Note: The bidder must submit all relevant documents as per qualification criteria and tender conditions. No correspondence to the agency will be done for shortfall documents.

Original documents to be brought by bidder/authorized person for verification on the date and time as communicated by engineer-in-charge. Successful bidder to submit hard copy of tender documents including addenda/Corrigendum, if any and other supportive documents as required in this tender, duly stamped & signed on all pages.

ADDL.CITY ENGINEER
Rajkot Municipal Corporation

Signature of contractor with seal

Check List for submission of Documents Tab	
Tender Fee submitted as per Tender	Yes/No
Tender Earnest Money Deposit submitted as per Tender	Yes/No
Registration documents submitted as per tender requirement	Yes/No
Financial Details:	
Turnover details submitted as per requirement	Yes/No
Working Capital as per requirement of tender is submitted	Yes/No
Valid Bank Solvency submitted	Yes/No
Validity of Bank Solvency	Date:
Experience Details:	
Details of Technical Staff and details of machineries submitted	Yes/No
Address proof submitted	Yes/No
Identity proof submitted	Yes/No
Fresh Declaration on Non-Judicial Stamp Paper regarding not black listed or Terminated or Debarred, is	Yes/No
Professional Tax Receipt of current	Yes/No

Note:

Over and above, the agency shall also have to submit all other necessary documents as may be required for pre-qualification, failing which, the agency will be treated as Non-responsive and will be DISQUALIFIED and also the online price bid of such agency will not be opened.

Signature of contractor with seal

**INSTRUCTIONS
TO
BIDDERS**

INSTRUCTIONS TO BIDDER

IT 1. GENERAL

The contract documents may be secured in accordance with the Notice Inviting E-TENDER for the work called. The work shall include supply of materials necessary for construction of the work.

IT 2. INVITATION TO E-TENDER

The Rajkot Municipal Corporation hereinafter referred as the Corporation will receive e-Tenders for the work of as per the specifications and schedule of prices in the e-Tender document. The e-Tenders shall be opened online as specified in the e-Tender notice in the presence of interested Bidders or their representatives. The Corporation reserves the right to reject the lowest or any other or all e-Tenders or part of it which in the opinion of the Corporation does not appear to be in its best interest, and the Bidder shall have no cause of action or claim against the Corporation or its officers, employees, successors or assignees for rejection of his e-Tender.

IT 3. LANGUAGE OF e-TENDER

E-TENDERS shall be submitted in English, and all information in the e-Tender shall also be in English, Information in any other language shall be accompanied by its translation in English. Failure to comply with this may make the e-Tender liable to rejection.

IT 4. QUALIFICATIONS OF BIDDERS

- A. The Bidders shall abide by the laws of the Union of India and of Gujarat State and legal jurisdiction of the place where the works are located.
- B. The Bidder shall furnish a written statement of financial and technical parameters with details and documents along with his e-Tender which contains namely as below:
 - i. The Bidder's experience in the fields relevant to this contract.
 - ii. The Bidder's financial capacity/resources and standing over at least 7 (Seven) years.
 - iii. The Bidder's present commitments (Jobs on hand).
 - iv. The Bidder's capability and qualifications of himself and his regular staff etc.
 - v. Plants and Machinery available with the Bidder for the work e-Tendered.
- C. Joint venture: (N.A.)
- D. For the work mentioned above Joint Venture shall be allowed with maximum number of partner two, however all the fees, guarantee amount etc will be in the name of lead partner.
- E. In Joint Venture, the lead partner as well as any other partner should have experience of similar nature of work, minimum 15 % of the estimated cost.

In case of Joint venture the tender evaluation will be as under:

Financial: -

The finance of each partner will be consider proportionate to their share in the Joint venture agreement.

Technical: -

The experienced of each partner will be added in the tender evaluation.

Bids submitted by a joint venture of two firms as partners shall comply with the following requirements.

Tender fee, Earnest Money Deposit, Security Deposit and other financial details will be in the name of the lead partner.

All the partners shall have to enter into the Joint venture agreement and original agreement duly notarized shall have to be submitted along with tender documents.

The bid, and in case of a successful bid, the Form of Contract Agreement, shall be signed so as to be legally binding on all partners.

One of the partners shall be authorized to be in charge, and his authorization shall be evidenced by submitting a power of attorney by legally authorized signatories of all the partners.

The partner in charge shall be authorized to incur liabilities, receive payments and receive instructions for and on behalf of any or all partners of the joint venture and the entire execution of the Contract.

All partners of the joint venture shall be jointly and severally liable for the execution of the Contract in accordance with the Contract terms and relevant statement to this effect shall be included in the authorization mentioned under (iv) above as well as in the Bid Form and the Form of Contract Agreement (in case of successful bid); and Permissible Joint venture partners shall be restricted to two numbers.

The owner or the Engineer-in-charge is not obliged to disclose his findings or his Assessment.

The Bidder shall furnish original documents on the date mentioned in tender notice. The bid for those bidder will be treated as non-responsive who failing to produce original documents on specified date.

IT 5. e- TENDER DOCUMENTS

The e-Tender documents and drawings shall comprehensively be referred to as e-TENDER document. The several sections form in the document are the essential parts of the contract and a requirement occurring in one shall be as binding as though occurring in all, they are to be taken as mutually, explanatory and describe and provide for complete works.

IT 6. EXAMINATION BY BIDDERS

- A. At this own expense and prior to submitting his e-Tender, each Bidder shall (a) examine the Contract Documents, (b) visit the site and determine local conditions which may affect the work including the prevailing wages and other pertinent cost factors, (c) familiarize, himself with all central, state and local laws, ordinance, rules regulations and codes affecting the material supply including the cost of permits and licenses required for the work and (d) correlate his observations, investigations, and determinations with the requirements of the e-TENDER Documents, site & subsoil investigation.
- B. The e-Tender is invited on ..%. rate and contractor shall have to quote his price on % bases above or below in the schedule -B./ Price Schedule. The works shall have to be completed in all respect as stated in the e-Tender document to the satisfaction of the Corporation.
- C. The following comprises in Contract Documents at a price of Rs.1875-00
- D. .e-TENDER Document:

Part-I

1. Notice inviting Bidders.
2. Instructions to the Bidder.
3. Formats
4. General conditions of contract

Part-II

Technical specifications

Part-III

- a. Bid Form (With Price)
- b. Preamble to Price schedule
- c. Price Schedule (Schedule-B)

General Specifications

1. General note & site description.
2. Definition.
5. Scope of Contract.
6. e- Tender price.
7. Completion Schedule.
8. Site investigation.
9. Contractor's responsibility.
10. Safety.
11. Quality Assurance.
12. Classification of Strata

- E. Copy of the E-TENDER Document should be completed, checked in a responsible manner, digitally signed, and submitted. Security Bond shall be submitted in person by the stipulate date, which shall form the e-Tender.

The e-Tender is required to complete with all the pages in which entries are required to be made by the Bidder are contained in the e-Tender documents and the Bidder shall not take out or add to or amend the text of any of the documents except in so far as may be necessary to comply with any addenda issued pursuant to Clause IT.17 hereof.

IT 7. EARNEST MONEY DEPOSIT:

- A. Each Bidder must submit a receipt of deposit as Tender guarantee towards Earnest money amounting to Rs.44,250/-in any form mentioned below:
- a) By a Demand Draft on the Rajkot Branch of any Nationalized Bank or Scheduled Bank except co-operative bank. It can be directly deposited in the account of Rajkot Municipal Corporation.
 - b) A Bank Guarantee from Rajkot Branch of any Nationalized Bank or Scheduled Bank except co-operative bank. It shall be valid for a period of not less than Three hundred and Sixty (360) days from the date of submission.

EMD shall comply with the requirements for Bond as stipulated in the General conditions of contract. The Tender guarantee bond will be held by the owner as a guarantee that the Bidder, if awarded the contract, will enter into the contract agreement in good faith and furnish the required bonds. Any e- Tender not accompanied by a Tender guarantee in the form of earnest money deposited for the sum stipulated in the e-Tender Document will be summarily rejected.

- B. The Earnest Money Deposit will be refunded to the unsuccessful Bidders after an award has been finalized.
- C. The Earnest Money Deposit (Tender Guarantee) will be forfeited in event the successful Bidder fails to accept the contract and fails to submit the "Performance Guarantee Bonds to the Owner as stipulated in this e-Tender document within ten (10) days after receipt of notice of award of contract.

The successful Bidder shall furnish the required Security Deposit for performance and plus additional security if any for unbalanced bids in accordance with the condition of the contract and attend the office of the Engineer In-charge for execution of the contract documents. If he fails to

furnish the Security Deposit for performance or enter into an agreement to execute the contract for the work offered to him, his Earnest Money Deposit will be forfeited and the Bidder will be Black Listed / Debarred from tendering for further works of Rajkot Municipal Corporation for the period of three years.

- D. The Earnest Money Deposit of the successful Bidder shall be returned after the performance guarantee bond, as required, is furnished by the contractor.
- E. No interest shall be paid by the owner on any e-Tender guarantee.

IT 8. INCOME TAX CLEARANCE CERTIFICATE : (DELETED) :

Latest Income Tax clearance Certificates must accompany with the e-Tender without which the e-Tender is liable to be summarily rejected. The Income Tax Clearance Certificate obtained from the Income Tax Officer shall clearly indicate the Income Tax Pan No/Circle/Ward, District and the reference number of the assessment along with the assessment year.

IT 9. PREPARATION OF e-TENDER DOCUMENTS

Bidders are required to note the following while preparing the e-TENDER Documents:

- A. e-TENDER shall be submitted on the e-TENDER form bound here in English. All statements shall be properly filled in. Numbers shall be stated both in words and in figures where so indicated.
- B. All entries or prices and arithmetic shall be checked before submission of the e-TENDER. If there is discrepancy between the rates quoted in figures and in words, the rates expressed in words shall be considered as binding.
- C. Each e-Tender shall be accompanied by the prescribed e-Tender security bond and other required documents and drawings. All witnesses and sureties shall be persons of status and probity and their full names, occupations and addresses shall be stated below their signature.
- D. Variation to the contract Documents requested by the Bidder may be affixed and duly signed and stamped. Such variations may be approved or refused by the Corporation is not obliged to give reason for his decisions.

IT 10. SUBMISSION OF e-TENDER DOCUMENTS

Bidders are requested to submit the e-TENDER Documents on following lines.

- A. Volume containing following documents :
 - I. Earnest Money Deposit.
 - II. Certificates as registered contractor in appropriate class with Government of Gujarat or appropriate authority.
 - III. Bidder's financial capability statement including last three years Income tax returns, balance sheet, duly signed by registered chartered account.
 - IV. Bidder's experience in the field relevant to this contract.
 - V. A list of the equipment the Bidder possesses and that which he proposed to acquire and use for the purpose related to the work.

The time limit for receipt of e-Tender shall strictly apply in all cases. The Bidders should therefore ensure that their e-Tender is received by the competent authority The Rajkot Municipal Corporation at before expiry of the time limit. No delay on account of any cause for receipt of e-Tender shall be entertained.

The e-Tender must contain the name address of residence and place of business of the person or persons submitting the e-Tender and must be digitally signed.

e-TENDER by partnership firm must be furnished with the full names and addresses of all partners and be signed by one of the members of the partnership or by a legally authorized representative holding power of attorney followed by signature and designation of the person of person signing.

e- TENDER by Corporations/Companies must be signed with the legal name of the Corporation/Companies by the president/or by the secretary or other person or persons legally authorized to bind the Corporation/Company in the matter.

IT 11 TENDER VALIDITY PERIOD

The validity period of the e-Tender submitted for this work shall be of 120 days from the date of opening of the e-Tender and that the Bidder shall not be allowed to withdraw or modify the e-Tender offer on his own during the validity period. The Bidder will not be allowed to withdrawn the e-Tender or make any modifications or additions in the terms and conditions on his own e-Tender. If this is done then the owner shall, without prejudice to any other right or remedy, be at liberty to reject the e- Tender and forfeit the earnest money deposit in full.

IT 12 GENERAL PERFORMANCE DATA

Bidder shall present all the information which sought for in the e-Tender document in form of various schedules if given. e- TENDERS may not be considered if left blank or the schedules are not properly filled in.

IT 13 SIGNING OF e-TENDER DOCUMENTS

If the Tender is made by an individual it shall be signed with his full name above his current address. If the Tender is made by a proprietary firm, it shall be signed by the proprietor above his name and the name of his firm with his current address.

If the e-Tender is made by a firm in partnership, it shall be signed by all the partners of the firm above their full names and current address, or by a partner holding the power of attorney for the firm, in which case a certified copy of the power of attorney shall accompany the e-TENDER. A certified copy of the partnership deed, current addresses of all the partners of the firm shall also accompany the e-Tender.

If the e-Tender is made by a limited company or a limited corporation, it shall be signed by a duly authorized person holding the power of attorney, shall accompany the e-Tender. Such limited company or corporation may be required to furnish satisfactory evidence of its existence before the contract is awarded.

If the e-TENDER is made by a group of firms, the sponsoring firm shall submit complete information pertaining to each firms in the group and state along with the bid as to which of the firms shall have the responsibility for e-Tendering and for completion of the contract documents and furnish evidence admissible in law in respect of the authority to such firms on behalf of the group of firms for e- Tendering and for completion of contract documents. The full information and satisfactory evidence pertaining to the participation of each member of the group of firms in the e-Tender shall be furnished along with the e-Tender.

All witnesses and sureties shall be persons of status and probity and their full names, occupations and addresses shall be stated below their signatures. All the signatures in the e-Tender document shall be dated.

IT 14 WITHDRAWAL OF TENDERS

If, during the tender validity period, the Bidder withdraws his Tender, Tender security (Earnest Money) shall be forfeited and Bidder will be debarred for next three years to quote in R.M.C.

IT 15 INTERPRETATIONS OF e-TENDER DOCUMENTS

Bidders shall carefully examine the e-TENDER Document and fully inform themselves as to all the conditions and matters which may in any way affect the work or the cost thereof. If a Bidder finds discrepancies, or omission from the specifications or other

documents or should be in doubt as to their meaning, he should at once address query to the ADDL. CITY ENGINEER, R.M.C. The result of interpretation of the e-TENDER will be issued as addendum.

IT 16 ERRORS AND DISCREPANCIES IN e-TENDERS

In case of conflict between the figures and words in the rates the rate expressed in words shall prevail and apply in such cases.

IT 17 MODIFICATION OF DOCUMENTS

Modification of specifications and extension of the closing date of the e-Tender, if required will be made by an addendum. Each addendum will be made available online to all Bidders. These shall form a part of e-Tender. The Bidder shall not add to or amend the text of any of the documents except in so far as may be necessary to comply with any addendum.

ADDENDA

Addenda form part of the Contract Documents, and full consideration shall be given to all Addenda in the preparation of e-Tender. Bidders shall verify the number of Addenda issued, if any and acknowledge the receipt of all Addenda in the e-TENDER Failure to so acknowledge may cause the e-Tender to be rejected.

A. The Owner may issue Addenda to advise Bidders of changed requirements. Such addenda may modify previously issued Addenda.

B. No addendum may be issued after the time stated in the notice inviting e - Tenders.

IT 18 TAX AND DUTIES ON MATERIALS

All charge on account of excise duties, Central / State, sales tax, work contract tax and other duties etc. on materials obtained for the works from any source shall be borne by the contractors. No (P) or 'C' or 'D' form shall be supplied.

IT 19 EVALUATION OF E - TENDERS

While comparing e-Tenders, the Rajkot Municipal Corporation shall consider factors like price offer is workable with the market price, efficiency and reliability of construction method proposed, compliance with the specifications, relative quality, work done in past with Rajkot Municipal Corporation or other Government Organizations, litigation issues etc. Evaluation criteria specifically mentioned in the specification will also be taken into consideration in the evaluation of e- Tenders.

IT 20 TIME REQUIRED FOR COMPLETION

The completion period mentioned in this schedule is to be reckoned from the date of notice to proceed. Total completion period is **09 months** from the date of issue of notice to proceed and contractor should adhere to this completion time. Monsoon period from 1st July to 30th September will be considered as non-working period and hence excluded in time limit.

IT 21 POLICY FOR TENDER UNDER CONSIDERATION

TENDER shall be termed to be under consideration from the opening of the e - Tender until such time any official announcement or award is made.

While e-Tenders are under consideration, Bidders and their representative or other interested parties are advised to refrain from contacting by any means any corporations personnel or representatives on matters related to the e-Tenders under study. The Corporation's representatives if necessary will obtain clarification on e-Tenders by requesting such information from any or all the Bidders, either in writing or through personal contact, as may be necessary. The Bidder will not be permitted to change the substance of his e-Tender after e-Tenders have been opened. This includes any post Tender price revision. Non-compliance with his provision shall make the Tender liable for rejection.

IT 22 PRICES AND PAYMENTS

The Bidder must understand clearly that the prices quoted are for the total works or the part of the total works quoted for and include all costs due to materials, labour, equipment, supervision, other services, royalties, taxes etc. and to include all extra to cover the cost. No claim for additional payment beyond the prices quoted will be entertained and the Bidder will not be entitled subsequently to make any claim on any ground.

IT 23 PAYMENT TERMS

The terms of payment are defined in the General Conditions of Contract and Technical specifications. The Corporation shall not under any circumstances relax these terms of payment and will not consider any alternative payment terms. Bidders should therefore in their own interest note this provision to avoid rejection of their e-Tenders.

IT 24 AWARD

Award of the contract or the rejection of e-TENDERS will be made during the Tender validity period. A separate Schedule-B (Price Schedule) is given. The contractors are requested to quote their price offer in % below or above on the given price in the schedule-B of Price Schedule only.

- A. After all contract contingencies are satisfied and the Notice of Award is issued, the successful Bidder shall execute the Contract Agreement within the time stated and shall furnish the Bond as required herein. The contract Agreement shall be executed, in form stipulated by the Owner.
- B. If the Bidder receiving the Notice of Award fails or refuses to execute the Contract Agreement within the stated time limit or fails or refuses to furnish the Bond as required herein. The Owner may annul his award and declare the e-Tender security forfeited and will take action as deemed fit.
- C. A corporation, partnership firm or other consortium acting as the Bidder and receiving the award shall furnish evidence of its existence and evidence that the officer signing the contract agreement and Bonds for the corporation, partnership firm or other consortium acting as the Bidder is duly authorized to do so.

IT 25 SIGNING OF CONTRACT

The successful Bidder shall be required to execute the contract agreement within 10 days of receipt of intimation to execute the contract, failing which the Corporation will be entitled to annul the award and forfeit the Earnest Money Deposit. The person to sign the contract document shall be person as detailed in Article IT.13 (signing of e-Tender documents).

IT 26 DISQUALIFICATION

- A e-Tender shall be disqualified and will not be taken for consideration if,
- (a) The envelope does not show on the outside the reference of bid and thus gets opened before the due date of opening (as per Article IT 10 i.e. submission of tender document)
 - (b) The Tender fee and Tender Earnest Money Deposit is not deposited in full and in the manner as specified as per Article IT.7 i.e. Earnest Money Deposit.
 - (c) The e-Tender is in a language other than English or does not contain its English Translation in case of other language adopted for e-Tender preparation.
 - (d) The e-Tender documents are not signed by an authorized person (as per Article IT. 13 i.e. signing of e-Tender documents).
 - (e) The general performance data for qualification is not submitted fully (as per Article IT 12 i.e. General performance Data).
 - (f) Bidder does not agree to payment terms defined as per Article IT. 23 i.e. payment terms.

- A. A e-Tender may further be disqualified if,
- (a) Price variation is proposed by the Bidder on any principle other than those provided in the e-TENDER Documents.
 - (b) Completion schedule offered is not consistent with the completion schedule defined and specified in e-Tender document.
 - (c) The validity of e-Tender bond is less than that mentioned in Article IT. 11 i.e. e - Tender validity period.
 - (d) Any of the page or pages of e-Tender is/are removed or replaced.
 - (e) Any conditional tender.
 - (f) All corrections or posted slips are not initiated by Bidder.
 - (g) Any erasure is made in the e-tender.

IT 27 PERFORMANCE GUARANTEE (SECURITY DEPOSIT)

As a contract security the Bidder to whom the award is made shall furnish a performance guarantee (Security deposit) for the amount of 5% of the contract price to guarantee the faithful performance, completion and maintenance of the works of the contract in accordance with all conditions and terms specified herein and to the satisfaction of the Engineer-in-charge and ensuring the discharge of all obligations arising from the execution of contract.

Additional performance guarantee is payable if,

1. the contract price offered by the selected bidder is lower than 10% but up to 20% of the estimated project cost than the additional performance security shall be calculated @ 20% of the difference in the estimated project cost minus 10% of the estimated project cost and Contract price offered by the selected bidder.
2. the contract price offered by the selected bidder is lower than 20% of the Estimated project cost than the additional performance security shall be calculated @ 30% of the difference in the Estimated project cost minus 10% of the Estimated project cost and Contract price offered by the selected bidder.

This additional performance security shall be treated as part of the performance security.

Performance security shall be valid beyond 60 days of the defect liability period and the additional performance security shall be valid beyond 28 days of project completion date.

Final SD will be calculated at the time of final bill i.e. actual completion amount.

Performance as mentioned above may be in the forms mentioned below:

- d) By a Demand Draft on the Rajkot Branch of any Nationalized Bank or Scheduled Bank except co-operative bank.
- e) A fixed deposit receipt of any Schedule Bank or Nationalized Bank (except Co-operative Bank) duly endorsed in favour of the Rajkot Municipal Corporation, Rajkot.
- f) A Bank Guarantee from Rajkot Branch of any Nationalized Bank or Scheduled Bank except co-operative bank.

The performance guarantee shall be delivered to the Corporation within Ten (10) days of the notice of award and at least three (3) days before the contract agreement is signed unless otherwise specified by the Engineer-in-charge. Alternatively, the contractor may at his option deposit an amount of 2.5% of the value of the contract price within ten days and the balance 2.5% to be recovered in installments through deduction @ the rate of 10% from the running account bills. It is further clarified that Performance Guarantee (SD) for extra work will also be recovered @ 10% from the bill of extra work i.e. works beyond tender amount.

On due performance and completion of the contract in all respects, THE PERFORMANCE GUARANTEE (SECURITY DEPOSIT) WILL BE RELEASED TO THE CONTRACTOR WITHOUT ANY INTEREST AFTER DEFECT LIABILITY PERIOD IS OVER.

IT 28 STAMP DUTY

The successful Tenderer shall have to enter into an agreement on a non-judicial stamp paper of amount as per Stamp Duty Act in the form of the agreement approved by the Corporation. The cost of stamp paper and adhesive stamp shall be borne by the contractor.

IT 29 BRAND NAMES

Specific reference in the specifications to any material by manufacturer's name, or catalogue shall be constructed as establishing a standard or quality and performance and not as limiting competition and the Bidder in such cases, may at his option freely use only other product, provided that it ensures an equal or higher quality than the standard mentioned and meets Corporation approval.

IT 30 NON TRANSFERABLE

e- TENDER documents are not transferable.

IT 31 COST OF e-Tendering

The owner will not defray expense incurred by Bidders in e - Tendering.

IT 32 EFFEECT OF e-Tender

The e-Tender for the work shall remain for a period of 180 days from the date of opening of the e-Tenders for this work and that the Bidder shall not be allowed to withdraw or modify the offer in his own during the period. If any Bidder withdraws or makes any modification or additions in the terms and conditions of his own e-Tender, then the Corporation shall, without prejudice to any other right or remedy, be at liberty to reject the e-Tender and forfeit the earnest money in full.

IT 33 CHANGE IN QUANTITY

The Corporation reserves the right to waive any information in any e-Tender and to reject one or all e-Tenders without assigning any reasons for such rejection and also to vary the quantities of items or group as specified in the scheduled of prices as may be necessary.

IT 34 NEW EQUIPMENT AND MATERIAL

All materials, equipment and spare parts thereof shall be new, unused and originally coming from manufacturer's plant to the Corporation. The rebuilt or overhauled equipment/materials will not be allowed to be used on works.

IT 35 RIGHTS RESERVED

The owner reserves the right to reject any or all e-Tenders, to waive any informality or irregularity in any e-Tender without assigning any reason. The owner further reserves the right to withhold issuance of the notice to proceed, even after execution of the contract agreement. No payment will be made to the successful Bidder on account of such withholding. The owner is not obliged to give reasons for any such action.

IT 36 ADDITIONAL RIGHTS RESERVED

The Commissioner, Rajkot Municipal Corporation, reserves right to reduce the scope of work & split the e-Tender on two or more parts without assigning any reason even after the awards of contract.

IT 37 MOBILIZATION ADVANCE

No mobilization advance or advance on machinery will be given.

IT 38 CONDITIONAL e-Tenders

The scope of work is clearly mentioned in the e-Tender documents. The contractor shall have to carry out the work in accordance with the details specifications. No condition will be accepted. The conditional e-Tender will liable to be rejected.

IT 39 CESS & REGISTRATION:

For the welfare of labour working under construction Industry, the agency shall have to take the registration with competent authority as per Circular No.CWA/2004/841/M-3 dated 30-01-2006 of Government of Gujarat. Rajkot Municipal Corporation will deduct prevailing CESS of the value of work and will deposit the same in Government.

IT 40 ESI REGISTRATION:

The contractors who are liable to be registered under ESI Act must possess ESI registration number at the time of filling of tender. The agency should follow all the rules and regulations of ESI Act as per prevailing norms.

IT 41 PROFESSIONAL TAX

The bidder shall have to pay the Professional Tax for current financial year imposed by Government of Gujarat, and also the bidder shall have to produce Enrollment Certificate for the same.

IT 42 PF CODE:

The contractors who are liable to be registered under EPF Act, 1950 must possess EFP code at the time of filling of tender. The agency should follow all the rules and regulations of the Act as prevailing currently.

IT 43 LABOUR LICENSE:

The contractors who are liable to be registered under Contract Labour Act, 1970 must possess online Labour License at the time of filling of tender. The agency should follow all the rules and regulations of the Act as prevailing currently.

IT 44 FILLING OF e-TENDER

The bidder shall have to fill all the details required in on-line bidding form of e-Tender. Incomplete OR inappropriate OR wrong information filled may cause the e-Tender to be rejected.

Addl/Asst. Engineer
R.M.C.

Dy.Ex.Engineer
R.M.C.

ADDL. CITY ENGINEER
R.M.C.

Signature of Contractor with Seal

F O R M A T S

Financial & Other Statements

Information / Details to be submitted by the Bidders in the Performa mentioned under Statement no 1 to 9. All the documents submitted herewith as supporting documents shall be duly attested and certified true copy.

STATEMENT NO-1

DECLARATION

I / We _____ hereby declared that I am / We partner(s) are not black listed or Terminated or Debarred or suspended, backed out, delisted or connected with firm black listed or terminated or debarred or suspended or backed out or delisted in any States, CPWD/ MES/ Railways or any Government, Semi- Government or Private body since the inception of the firm / company. Also, no Police complaint is lodged against the firm / company or Staff deployed by me / us.

At present I am / we are registered as approved contractor(s), firms in _____ State, CPWD / MES / Railways.

I, owner / We, the partners of this firm, hereby give an undertaking that we are jointly and severally responsible to meet all the liabilities ever and above the business of this firm and make good the above financial loss sustained by the Rajkot Municipal Corporation as a result of our abandoning the works entrusted to us.

I further undertake that if above declaration proves to be wrong/ incorrect or misleading, our tender/ contract stands to be cancelled/ terminated.

Date:
Place:

Signature of Authorized Person

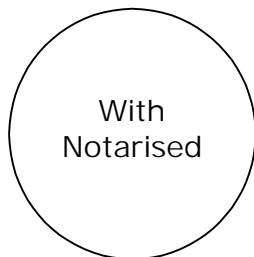

STATEMENT NO-2

APPLICABILITY OF PROVIDENT FUND AND MISCELLANEOUS
PROVISIONS ACT 1952

Successful bidder i.e. the agency whose tender is accepted by the RMC shall have to comply the necessary formalities under the employees provident fund and Miscellaneous Provisions Act, 1952 as Contributory Provident Fund Scheme is applicable to labourers engaged in construction activity and shall have to submit proofs regarding deduction of provident fund and other dues and depositing the same with government department under the act and the scheme regularly on monthly basis failing which no running / final bill payment will be made by the RMC to the contractor in any circumstances.

A certificate to the above effect has to be given by the contractor as under.

Declaration
Of
Depositing Provident Fund contribution

This to certify that we have deducted the employees' P.F. and deposited the same along with employer's contribution towards provident fund on labour charges / wages paid by us to the labourers engaged for the work of _____
_____with Provident
Fund Authority under our Provident Fund Code No. _____

We produce herewith the copies of the challans for the provident fund deduction and contribution deposited as mentioned above.

Date:
Bidder

Seal and Signature of the

CURRICULAM VITAE

Sr.No.	Details of person	
1.	Name	
2.	Age	
3.	Qualifications	
4.	Experience in Project Related field	
5.	Other experiences	
6.	Employment Record.	

Sr. No.	Period From - To	Organization under which work	Status /position in the

Note:

- (1) Separate sheet for each person to be furnished as above.
- (2) The contractor's Project Team should consist of persons in the following disciplines.
 - a) Senior Engineer with experience of Building work
 - b) Senior material Engineer.
 - c) Senior Quantity Surveyor.
 - d) Project management expert.
 - e) Site in charge

STATEMENT – 4

I NFORMATION REGARDING FINANCIAL CAPACITY
OF THE CONTRACTORS

Sr.	Details	Amount (Rs. in lakhs)	Remarks
1.	Solvency		A Banker's Certificate of current financial year may please be attached.
2.	Annual Turnover for the last seven		Certified true copy to be attached
3.	Price of biggest (road work) job		Certified true copy to be attached

STATEMENT NO. – 4/A

BIDDER'S FINANCIAL CAPACITY

Sr. No.	Financial Year	Annual Turnover in Engineering Project Rs.	Net worth Rs.	Net Cash Rs.	Working Capital Rs.
1	2023-2024				
2	2022-2023				
3	2021-2022				
4	2020-2021				
5	2019-2020				
6	2018-2019				
7	2017-2018				

Note:-

- 1) Figures to be taken from audited balance sheets. Duly certified attested true copy
- 2) Copies of the balance sheet to be attached..
- 3) The bidder shall have to provide that for a period of at least 3 months the bidder has ability to sustain negative cash balance and how he proposes to meet with the same.
- 4) Cash Plan / Cash flow Statement.

STATEMENT NO. – 4 / B

AVAILABLE BID CAPACITY

	2017-18	2018-19	2019-20	2020-21	2021-22	2022-23	2023-24
Value of works executed in Rs. Crores.							

The available bid capacity will be worked out as follows.

Available bid capacity = $(A \times N \times 2) - B$, where

- A = Maximum of updated total amount of work executed in any one year of the last five financial years.
- B = The amount of the existing commitments and ongoing works to be discharge during time interval of N years from the bid due date.
- N = Number of years prescribed for completion of the proposed works

STATEMENT NO. – 5

LIST OF SINGLE PROJECT WORK OF NOT LESS THAN 60% OF THE ESTIMATED COST COMPLETED DURING THE LAST SEVEN YEARS.

Sr. No	Year of Construction work	Name of Project	Name of owner & contact person of the project, address, phone	Total cost of the work	Total value of work done	Date of starting work	Date of Actual completion of work
1	2	3	4	5	6	7	8
1							
2							
3							
4							
5							
6							
7							
8							
9							
10							

Note: Certificate from the owners in support of above works may be enclosed with this statement.

STATEMENT NO. 5/ A

Detailed information of similar type of work costing not less than 50% of tender amount completed with good quality and workmanship in the past seven years.

Name of Contractor: _____

Sr. No.	Name of work	Name of client	Estimated cost of work (Rs. Lakhs)	Tendered amount (Rs. Lakhs)	Date of Award of contract	Target date of completion	Actual date of completion	Reason for delay	Amount of work done during last seven years preceding this tender (Rs. Lakhs).							Amount of work done after March 2021 (Rs. Lakhs)	Remarks
									2017	2018	2019	2020	2021	2022	2023		
									2017	2018	2019	2020	2021	2022	2023		
									-	-	-	-	-	-	-		
									18	19	20	21	22	23	24		

Note: Certificate from the owners in support of above works may be enclosed with this statement.

STATEMENT NO – 5/B

DETAILS OF IMPORTANT CONSTRUCTION PROJECTS

Sr. No	Name of Project	Estimated cost	Prescribed time of performance		Actual Completion		Actual Completion Cost Rs.	Name, address and
			Start Date	Completion Date	Start Date	Completion Date		
1	2	3	4	5	6	7	8	9

Note: Certificate from the owners in support of above works may be enclosed with this statement.

STATEMENT NO. – 5/C

DETAILS OF ONGOING PROJECT

Sr. No	Name of project	Value of remaining work Rs. in lakhs.	Start date	Likely date of completion	Name, address, telephone, fax no. of project authority and contact person.

STATEMENT NO.-6

DETAILS OF PLANT & MACHINERY TO BE DEPLOYED ON THIS WORK

Name of the contractor/company_____

Sr. No	Name of plants/machinery	Nos. available (with make & year)	Nos. proposed to be deployed for this project	Present location	Present value of plant/ machineries
1	2	3	4	5	6

Note:

Plant / machineries which are proposed to be procured shall have to be procured at the earliest after award of the work and before the start of the work.

STATEMENT NO. 7METHOD STATEMENT AND WORK PLAN

The Bidder shall have to provide a brief write up to be enclosed with the "Technical Bids" covering his approach and methodology to handle the project construction activities including his details work plan. The brief shall include the following aspects.

Sr. No.	Components	
1.	Methodology	
2.	Construction equipment availability and plan of deployment.	
3.	PERT / Construction chart / Bar chart.	

Application Form(1) General Information

All individual firms and each partner of a consortium applying for qualification are requested to complete the information in this form. Nationality information to be provided for all owners or applicants who are partnerships or individually owned firms.

Where the Applicant proposes to use named subcontractors for critical components of the works, or for work contents in excess of 10 percent of the value of the whole works the following information should also be supplied for the specialist subcontractor(s).

1.	Name of Firm	
2.	Head office address	
3.	Telephone	Contact
4.	Fax	Telex
5.	Place of incorporation/registration	Year of incorporation/ registration

	Nationality of owners	
	Name	Nationality
1.		
2.		
3.		
4.		
5.		

Name of Bidders officers / Persons to be contacted			
Name.	Address	Phone Nos.	Fax.

Application Form (1A)

Structure and Organization

<p>The applicant is an individual a proprietary firm a firm in partnership a Limited Company or Corporation a group of firms/consortium (if Yes, give completion information in respect of each partner)</p>	
<p>Attach the Organization Chart showing the structure of the organization including the names of the Directors and position of officers</p>	
<p>Number of years of experience : as a Prime Contractor (contractor shouldering major responsibility in own country other countries (specify country)</p>	
<p>in a consortium in own country other countries (Specify country)</p>	
<p>as a sub-contractor (specify main contractor) in own country other countries (Specify country)</p>	
<p>4. Name and address of any associates the applicant has in India (in case the applicant happens to be from foreign country) who are knowledgeable in the procedures of customs, immigration, taxes and other information necessary to do the work.</p>	
<p>For how many years has your organization been in business of similar work under its present name? What were your fields when your organization was established? Whether any new fields were added in your organization? And if so, when?</p>	

<p>5. Were you ever required to suspend construction for a period of more than six months continuously after you started? If so, give the name of project and give reasons thereof.</p>	
<p>6. Have you ever left the work awarded to you incomplete? If so, give name of project and reasons for not completing work.</p>	
<p>In which fields of civil engineering construction do you claim specialization and interest?</p>	
<p>Give details of your experience in mechanized cement concrete lining and in modern concrete technology for manufacture and quality control.</p>	
<p>Give details of your experience in using heavy earth moving equipment and quality control in compaction of soils.</p>	
<p>Give details of your experience in Underground Drainage work in rocky area.</p>	
<p>Give details of civil work for drainage pumping station</p>	
<p>Give details for construction of sewerage treatment plant</p>	
<p>Give details for pumping machinery in drainage pumping station</p>	

GENERAL CONDITIONS OF CONTRACT

:: TABLE OF CONTESTS ::

No.	Description
GC-1	Definitions and Interpretations
GC-2	Location of site and accessibility
GC-3	Scope of work
GC-4	Ruling language
GC-5	Interpretation of Contract Document
GC-6	Contractor to understand himself fully
GC-7	Errors in submissions
GC-8	Sufficiency of E-TENDER
GC-9	Discrepancies
GC-10	Performance Guarantee (Security Deposit)
GC-11	Inspection of work
GC-12	Defect Liability
GC-13	Power of Engineer-In-Charge to give further instructions.
GC-14	Programme
GC-15	Sub-letting of work
GC-16	Sub-Contracts for temporary works, etc.
GC-17	Time for completion
GC-18	Extension of time
GC-19	Contract Agreement
GC-20	Liquidated damages
GC-21	Forfeiture of Security Deposit
GC-22	Action of Forfeiture of Security Deposit
GC-23	No compensation for alteration in or restriction in work
GC-24	In the event of death of contractor
GC-25	Members of the owner not individually liable
GC-26	Owner not bound by personal representations
GC-27	Contractor's office at site
GC-28	Contractor's subordinate staff and their conduct
GC-29	Termination of sub-contract by owner
GC-30	Power of entry
GC-31	Contractor's responsibility with the other Contractor and Agencies.
GC-32	Other Agencies at site
GC-33	Notices
GC-34	Rights of various interests
GC-35	Price adjustments
GC-36	Terms of Payment
GC-37	Retention Money
GC-38	Payments due from the Contractor
GC-39	Contingent Fee
GC-40	Breach of Contract by Contractor
GC-41	Default of Contractor
GC-42	Bankruptcy
GC-43	Ownership
GC-44	Declaration against waiver
GC-45	Laws governing the contract
GC-46	Over payment and under payment
GC-47	Settlement of disputes
GC-48	Disputes of differences to be referred to
GC-49	Arbitration
GC-50	Termination of the Contract

GC-51	Special risks
GC-52	Change in Constitution
GC-53	Sub-contractual relations
GC-54	Patents and Royalties
GC-55	Lien
GC-56	Execution of work
GC-57	Work in monsoon
GC-58	Work on Sundays and Holidays
GC-59	General Conditions for construction work
GC-60	Drawings to be supplied by the Owner
GC-61	Drawings to be supplied by the Contractor
GC-62	Setting outwork
GC-63	Responsibilities of Contractor for correctness of work
GC-64	Materials to be supplied by the Owner
GC-65	Conditions of issue of materials by the Owner
GC-66	Materials procured with assistance of the Owner
GC-67	Materials obtained from dismantling
GC-68	Article of value of treasure found during construction
GC-69	Discrepancies between instructions
GC-70	Alternations in specifications and designs and extra work.
GC-71	Action when no specifications are issued
GC-72	Abnormal rates
GC-73	Assistance to Engineer-In-Charge
GC-74	Tests for quality of work
GC-75	Action and compensation in case of bad workmanship
GC-76	Suspension work
GC-77	Owner may do part of the work
GC-78	Possession prior to completion
GC-79	Completion Certificate
GC-80	Schedule of Rates
GC-81	Procedure for measurement of work in progress
GC-82	Running account payments to be regarded as advances
GC-83	Notice for claim for additional payment
GC-84	Payment of Contractor's Bill
GC-85	Final Bill
GC-86	Receipt for payment
GC-87	Completion Certificate
GC-88	Taxes, Duties, etc.
GC-89	Insurance
GC-90	Damage to Property
GC-91	Contractor to Indemnify Owner
GC-92	Implementation of Apprentice Act 1954
GC-93	Health and Sanitary arrangements for workers
GC-94	Safety Code
GC-95	Accidents

GC-01

DEFINITIONS AND INTERPRETATIONS :

In the contract (as hereinafter defined) the following words and expressions shall, unless repugnant to the subject or context thereof, have the following means as signed to them.

The "Owner / Corporation" shall mean Rajkot Municipal Corporation and shall include its Municipal Commissioner or other Officers authorized by the Corporation and also include owner's successors and assignees.

The "Contractor" shall mean the person or the persons, firm or Company whose e-Tender has been accepted by the Owner and includes the Contractor's legal representative, his successors and permitted assigned.

DELETED

The "Engineer-In-Charge" shall mean the person designated as such by the owner from time to time and shall include those who are expressly authorized by the Corporation to act for and on its behalf for all functions pertaining to the operation of this contract.

Engineer-In-Charge's Representative shall mean any resident Engineer or Assistant to the Engineer-In-Charge appointed from time to time by the owner to perform duties set forth in the E-TENDER Document whose authority shall be notified in writing to the Contractor by the Engineer-In-Charge.

"E-TENDER" – the offer or proposal of the Bidder submitted in the prescribed form setting for the prices for the work to be performed, and the details thereof.

"Contract Price" shall mean total money payable to the Contractor under the contract.

"Addenda" shall mean the written or graphic notices issued prior to submission of e-Tender which modify or interpret the contract documents.

"Contract Time" – the time specified for the completion of work.

"Contract" shall mean agreement between the parties for the execution of works including therein all contract documents.

"Contract Document" shall mean collectively the e-Tender documents, designs, drawings, specifications, agreed variations, if any and such other documents constituting the e-Tender and acceptance thereof.

"The Sub-Contractor" shall mean any person, firm or company (other than the Contractor) to whom any part of the work has been entrusted by the Contractor with the written consent of the Engineer-In-Charge and the legal representative successors and permitted assignee of such person, firm or company.

The "Specifications" shall mean all directions, the various Technical Specifications, provisions and requirements attached to the contract which pertain to the method and manner of performing the work, to the quantities and qualities of the work and the materials to be furnished under the contract for the work and any order(s) or instruction(s) there under. It shall also mean the latest Indian Standard Institute Specification relative to the particular work or part thereof, so far as they are not

contrary to the E-TENDER specifications and in absence of any other Country applied in Indian as a matter of standard engineering practice and approved in writing by the Engineer-In-Charge with or without modification.

The "Drawings" shall include maps, plans, tracings, or prints thereof with any modification approved in writing by the Engineer-In-Charge and as such other drawings as may, from time to time, be furnished or approved in writing by the Engineer-In-Charge in connection with the work.

The "Work" shall mean the works to be executed in accordance with the contract or the part thereof as the case may be and shall include extra, additional, altered or substituted works as required for the purpose of the contract. It shall mean the totality of the work by expression or implication envisaged in the contract and shall include all materials, equipment and labour required for or relative or incidental to or in connection with the commencement, performance and completion of any work and / or incorporation in the work.

The "Permanent Work" shall mean works which will be incorporated in and form part of the work to be handed over to the owner by the Contractor on completion of the contract.

The "Temporary Work" shall mean all temporary works of every kind required in or about the execution, completion and maintenance of the work.

"Site" shall mean the land and other places, on, under, in or through which the permanent works are to be carried out and any other lands or places provided by the Corporation for the purpose of the contract together with any other places designated in the contract as forming part of the site.

The "Construction Equipment" shall mean all appliances / equipment of whatever nature required in or for execution, completion or maintenance of works or temporary works (as herein before defined) but does not include materials or other things intended to form or forming part of the permanent work.

"Notice in writing or written Notice" shall mean a notice written, typed or in printed form delivered personally OR sent by Registered Post to the last known private or business address or Registered Office of the Contractor OR through e-mail OR mobile message shall be deemed to have been received in the ordinary course of post it would have been delivered.

The "Alteration / variation order" shall mean an order given in writing by the Engineer-In-Charge to effect additions or deletions from or alterations in the work.

"Final Test Certificate" shall mean the final test certificate issued by the owner within the provisions of the contract.

The "Completion Certificate" shall mean the certificate to be issued by the Engineer-In-Charge when the work has been completed and tested to his satisfaction.

The "Final Certificate" shall mean the final certificate issued by the Engineer-In-Charge after the period of defects liability is over and the work is finally accepted by the owner.

"Defects Liability Period" shall mean the specified period between the issue of Completion Certificate and the issue of final certificate during which the Contractor is responsible for rectifying all defects that may appear in the works.

"Approved" shall mean approved in writing including subsequent confirmation in writing of previous verbal approval and "Approval" means approved in writing including as aforesaid.

"Letter of Acceptance" shall mean an intimation by a letter to Bidder that his e-Tender has been accepted in accordance with the provisions contained therein.

"Order" and "Instructions" shall respectively mean any written order or instruction given by the Engineer-In-Charge within the scope of his powers in terms of the contract.

"Running Account Bill" shall mean a bill for the payment of "On Account" money to the Contractor during the progress of work on the basis of work done and the supply of non-perishable materials to be incorporated in the work.

"Security Deposit" shall mean the deposit to be held by the owner as security for the due performance of the contractual obligations.

The "Appointing Authority" for the purpose of Arbitration shall be the Municipal Commissioner, Rajkot Municipal Corporation.

"Retention Money" shall mean the money retained from R.A.Bills for the due completion of the "LET WORKS".

Unless otherwise specifically stated, the masculine gender shall include the feminine and neuter genders and vice-versa and the singular shall include the plural and vice-versa.

GC-02

LOCATION OF SITE AND ACCESSIBILITY :

The site of tendered work is city roads in Rajkot lying in different wards. The intending bidders should inspect the site & make themselves familiar with site conditions and available communication facilities.

Non-availability of access roads shall in no case be the cause to condone delay in the execution of the work and no claim or extra compensation will be paid.

GC-03

SCOPE OF WORK :

The scope of work is defined broadly in the special conditions of contract and specifications. The Contractor shall provide all necessary materials, equipment and labour etc. for the execution and maintenance of the work. All material that goes with the work shall be approved by the Engineer-In-Charge prior to procurement and use.

Power Supply :

The Contractor shall make his own arrangement for power supply during installation.

Owner will not be in a position to provide land required for Contractor's field office, godown, etc. The Contractor shall have to make his own arrangement for the same.

GC-04

RULING LANGUAGE :

The language according to which the contract shall be construed and interpreted shall be English. All entries in the contract document and all correspondence between the contractor and the Corporation or the Engineer-In-Charge shall be in English/Gujarati. All dimensions for the materials shall be given in metric units only.

GC-05

INTERPRETATION OF CONTRACT DOCUMENT :

1. The provision of the General Conditions of Contract and Special Conditions of Contract shall prevail over those of any other documents of the contract unless specifically provided otherwise, should there be any discrepancy, inconsistency, error or omission in the several documents forming the contract, the matter may be referred to the Engineer-In-Charge for his instructions and decision. The Engineer-In-Charge's decision in such case shall be final and binding to the Contractor.
2. Works shown upon the drawings but not described in the specifications or described in the specifications without showing on the drawings shall be taken as described in the specifications and shown on the drawings.
3. The headings and the marginal notes to the clause of these General Conditions of Contract or to the specifications or to any other part of e-Tender documents are solely for the purpose of giving a concise indication and not a summary of contents thereof. They shall never be deemed to be part thereof or be used in the interpretation or construction of the contract.
4. Unless otherwise states specifically, in this contract documents the singular shall include the plural and vice-versa wherever the context so requires. Works imparting persons shall include relevant Corporations / Body of individual / firm of partnership.
5. Notwithstanding the sub-division of the documents into separate section and volumes every part of each shall be supplementary to and complementary of every other part and shall be read with and into the context so far as it may be practicable to do so.
6. Where any portion of the General Conditions of Contract is repugnant to or at variance with any provisions of the Special Conditions of Contract, then, unless a different intention appears, the provisions of the special conditions of contract shall be deemed to over ride the provisions of General Conditions of Contract to the extent of each repugnancy of variance.
7. The materials, design, and workmanship shall satisfy the relevant ISS, and codes referred to. If additional requirements are shown in the specifications, the same shall be satisfied over and above ISS and other codes.
8. If the specifications mention that the Contractor shall perform certain work or provide certain facilities, it shall mean that the Contractor shall do so at his own cost.
9. Contractor to Collect His Own Information -
The details given in the e-Tender are arranged making necessary investigations for framing an estimate. However, when the work is being executed, changes in soil conditions are likely to be met with in view of the formation of soil, strata in Rajkot District. It is, therefore, desirable that the Contractor makes his own investigations or additional investigations as

may be required for correctly assessing the cost of different items of work and submit his e-Tender accordingly. Any change in description or quantity of an item shall not vitiate the contract or release the Contractor from executing the work comprised in the contract according to the drawings and specifications at the e-Tendered rates.

He is deemed to have know the scope, nature and magnitude of the work and the requirements of materials and labour involved and as to whatever work he has to complete in accordance with the contract. The Contractor is expected to visit the site and surroundings to satisfy himself as to the nature of all existing structures, if any, and also as to the nature and the conditions of railways, roads, bridges and culverts, means of transport and communications whether by land, air or water and as to possible interruptions thereto and the access and gross from the site, to have examined and satisfied himself as to the sites for obtaining sand, stones, bricks and other materials, the site for disposal of surplus materials, the available accommodation and make such enquiries as may be necessary for executing and completing the work, to have local enquiries as to the sub-soil, subsoil water and variation thereof, storms, prevailing winds, climatic conditions and all other similar matters, effecting work. He is expected to be familiar with his liability for payment of Government taxes, customs and excise duty and other charges etc. in contract with the execution of this contract.

GC-06 CONTRACTOR TO UNDERSTAND HIMSELF FULLY :

The Contractor by e-Tendering shall be deemed to have satisfied himself, as to all considerations and circumstances affecting the e-Tender price, as to the possibility of executing the works as shown and described in the contract and to have fixed his prices according to his own view on these matters and to have understood that no additional allowances except as otherwise expressly provided, will afterwards be made beyond the contract price. The Contractor shall be responsible for any misunderstanding or incorrect information, however, obtained.

GC-07 ERRORS IN SUBMISSIONS :

The Contractor shall be responsible for any errors or omissions in the particulars supplied by him, whether such particulars have been approved by the Engineer-In-Charge or not.

GC-08 SUFFICIENCY OF e-TENDER :

The Contractor shall be deemed to have satisfied himself before e-Tendering as to the correctness of the e-Tender rates which rates shall, except as otherwise provides for, cover all the Contractor's liabilities and obligations set forth or implied in the contract for the proper execution of the work for compliance with requirements of Article GC-19 thereof.

GC-09 DISCREPANCIES :

The drawings and specifications are to be considered as mutually explanatory of each other, detailed drawings being followed in preference to small-scale drawings and figured dimensions in preference to scale and special conditions in preference to General Conditions. The special directions or dimensions given in the specifications shall supercede all else. Should any discrepancies however, appear or should any misunderstanding arise as to the meaning and intent of the said specifications or drawings, or as to the dimensions or the quality of the materials or the due and proper execution of the works, or as to the measurement or quality and valuation of the work executed under this contract or as extra there upon, the same shall be explained by the Engineer-In-Charge and his explanation shall be subject to the final decision of the Municipal Corporation in case reference be made to it, be binding upon the Contractor and the Contractor shall execute the work according to such explanation and without addition or to deduction from the contract price and shall also do all such works and things necessary for the proper completion of the works as implied by the drawings and

specifications, even though such works and things are not specially shown and described in the said specifications. In cases where no particular specifications are given for any article to be used under the contract, the relevant specifications of the Indian Standard Institution shall apply.

GC-10

PERFORMANCE GUARANTEE (SECURITY DEPOSIT) :

1. A sum of 5% of the contract price shall be deposited by the Bidder (herein after called the contractor when e-Tender is accepted) as security deposit with the owner for the faithful performance, completion and maintenance of the works in accordance with the contract documents and to the satisfaction of the Engineer-In-Charge and assuring the payment of all obligations arising from the execution of the contract. This shall be deposited in one of the forms mentioned below :
 - a. By a Demand Draft on the Rajkot Branch of any Scheduled Bank except co-operative bank.
 - b. A Fixed Deposit Receipt of a Schedule Bank duly endorsed in favour of the "RAJKOT MUNICIPAL CORPORATION", Rajkot.
 - c. The Contractor may pay 2.5% of the value of works as initial security deposit and the balance 2.5% shall be recovered in installments through deductions at the rate of 10 (ten) percent of the value of each Running Account Bill till the total security execution exceeds the accepted value of e-Tender because of allotment of further work, further recoveries towards security deposit shall be effected at 10% of the R A Bills to make up the five percent security deposit of the revised value of contract. Alternatively, the Contractor may at his option deposit the full amount of 5 percent of security deposit within ten days of receipt by him of the notification accepting the e-Tender in the form as aforesaid. PERFORMANCE GUARANTEE (SECURITY DEPOSIT) WILL BE RELEASED TO THE CONTRACTOR WITHOUT ANY INTEREST AFTER DEFECT LIABILITY PERIOD IS OVER.
2. If the Contractor, sub-contractor or their employees shall break, deface or destroy any property belonging to the owner or other agency during the execution of the contract, the same shall be made good by the contractor at his own expense and in default thereof, the Engineer-In-Charge may cause the same to be made good by other agencies and recover expense from the Contractor (for which the certificate of the Engineer-In-Charge shall be final). These expenses can be recovered from the security deposit if recovery from other sources is not possible. The amount as reduced in security deposit will be made good by deduction from the next R A Bill of the Contractor.

GC-11

INSPECTION OF WORK :

1. The Engineer-In-Charge shall have full power and authority to inspect the work at any time wherever in progress either on the site or at the Contractor's or any other manufacturer's workshop or factories wherever situated and the Contractor shall afford to Engineer-In-Charge every facility and assistance to carry out such inspection, Contractor or his authorized representative shall, at all time during the usual working hours and all times when so notified, remain present to receive orders and instructions.

Orders given to Contractor's representative shall be considered to have the same force as if they had been given to the Contractor himself. Contractor shall give not less than ten (10) days notice in writing to the Engineer-In-Charge before covering up or otherwise placing beyond reach of inspection and measurement any work in order that the same may be inspected and measured. In the event of breach of the above, the same shall be uncovered at Contractor's expenses for carrying out such inspection or measurement.

2. The material shall be dispatched from Contractor's store on site of work before obtaining approval in writing of the Engineer-In-Charge. Contractor shall provide at all times during the progress of work and maintenance period of proper means of access with ladders, gangways, etc. and make necessary arrangement as directed for inspection or measurement of work by Engineer-In-Charge.

GC-12

DEFECT LIABILITY :

1. Contractor shall guarantee the work for a period of 24 months. Any damage or defect that may arise or that may remain undiscovered at the time of issue of Completion Certificate connected in any way with the equipment or materials supplied by him or in the workmanship shall be rectified or replaced by Contractor at his own expense as desired by Engineer-In-Charge or in default Engineer-In-Charge may cause the same to be made good by other agency and deduct expenses of which the certificate of Engineer-In-Charge shall be final from any sums that may then or any time thereafter become due to Contractor or from his security deposit or the proceeds of sale thereof or of a sufficient portion thereof.
2. From the commencement to completion of work Contractor shall take full responsibility for the care of the work including all temporary works and in case any damages, occur from any cause whatsoever he shall at his own cost, repair and make good the same so that on completion, work shall be in good order and in conformity, in every respect, with the requirements of contract and as per the instructions of the Engineer-In-Charge.
3. If at any time before the work is taken over, the Engineer-In-Charge -
 - a) Decide that any work done or materials used by the Contractor are defective or not in accordance with the contract or that work or any portion thereof is defective or do not fulfill the requirements of contract (all such materials being herein after called defects in this clause) he shall, as soon as reasonably practicably, give notice to Contractor in writing of the said defect specifying particulars of the same then Contractor shall at his own expense and with all speed make good the defects so specified.
 - b) In case Contractor fails to do so, owner may take, at the cost of the Contractor, such steps as may in all circumstances be responsible to make good such defects. The expenditure so incurred by owner will be recovered from the amount due to Contractor. The decision of Engineer-In-Charge with regard to the amount to be recovered from Contractor will be final and binding on the Contractor.

GC-13

POWER OF ENGINEER-IN-CHARGE TO GIVE FURTHER INSTRUCTIONS:

The Engineer-In-Charge shall have the power and authority from time to time and at all times to give further instructions and directions as may appear to him necessary or proper for the guidance of the Contractor and the works and efficient execution of the works according to the terms of the specifications, and the Contractor shall receive, execute, obey and be bound by the same, according to the true intent and meaning thereof, as fully and effectively as though the same had accompanied or had been mentioned or referred to in the specifications. No work which radically changes the original nature of the contract shall be ordered by the Engineer-In-Charge and in the event of any deviation being ordered, which in the opinion of the Contractor changes the original nature of the contract, he shall nevertheless carry it out and any disagreement as to the nature of the work and the rate to be paid to thereof shall be resolved.

The time of completion of works shall, in the event of any deviations being ordered resulting in additional cost or reduction in cost over the contract sum, be extended or reduced reasonably by the Engineer-In-Charge. The Engineer-In-Charge's decision in the case shall be final and binding.

GC-14

PROGRAMME :

49

The time allowed for execution of works shall be the essence of the contract. The contract period shall commence from the date of notice of intimation to proceed. The Bidder at the time of submitting his e-Tender shall indicate in the construction schedule his programme of execution of work commencement with the total time specified. The Contractor shall provide the Engineer-In-Charge a detailed programme of time schedule for execution of the works in accordance with the specifications and the completion date. The entire programme to be finalized by the Contractor, has to conform to the execution period mentioned along with the Bill of Quantities in the e-Tender documents. The Engineer-In-Charge upon scrutiny of such submitted programme by Contractor, shall examine suitability of it to the requirement of contract and suggest modifications, if found necessary.

GC-15

SUB-LETTING OF WORK :

No part of the contract nor any share of interest thereon shall in any manner or degree be transferred, assigned or sublet by the Contractor directly or indirectly to any person, firm or Corporation whatsoever except as provided for in the succeeding sub-clause, without the consent in writing of the owner.

GC-16

SUB-CONTRACTS FOR TEMPORARY WORKS ETC. :

The owner may give written consent to sub-contractors for execution of any part of the works at the site, being entered upon the contractor provided each individual contract is submitted to the Engineer-In-Charge before being entered into and is approved by him. List of sub-contractors to be supplied.

Notwithstanding any subletting with such approval as afore said and notwithstanding the Engineer-In-Charge shall have received of any sub-contractors, the Contractor shall be and shall remain solely responsible for the quality and proper and expeditious execution of the works and the performance of all the conditions of contract in all respects as if such subletting or subcontracting had not taken place and as if such works had been done directly by the Contractor.

GC-17

TIME FOR COMPLETION :

1. The work covered under this contract shall be commenced from the date the Contractor is served with a notice to proceed with the work and shall be completed before the date as mentioned in the time schedule of work. The time is the essence of the contract and unless the same is extended as mentioned in Clause GC-18 "Extension of Time", the Contractor shall pay liquidated damages for the delay.
2. The general time schedule for construction is given in the e-Tender document. Contractor shall prepare a detailed weekly or monthly construction programme in consultation with the Engineer-In-Charge soon after the agreement and the work shall be strictly executed accordingly. The time for construction includes, the time required for testing, rectifications, if any, retesting and completion of the work in all respects to the entire satisfaction of the Engineer-In-Charge except the items which are not coming in the way to commission the project.
3. Monsoon period from 1st July to 30th September shall be considered as non-working period hence excluded in time limit.

GC-18

EXTENSION OF TIME :

Time shall be considered as the essence of the contract. If, however, the failure of the Contractor to complete the work as per the stipulated dates referred to above arises from delays on the part of Corporation in supplying the materials or equipment, it has undertaken to supply under the contract or from delays on the quantity of work to be done under the contract, or force majeure an appropriate extension of time will be given by the Corporation. The Contractor shall request for such extension within one month of the cause of such delay and in any case before expiry of the

GC-19 CONTRACT AGREEMENT :

The successful Bidder shall enter into and execute the contract agreement within 10 (ten) days of the notice of award, in the form shown in e-Tender documents with such modifications as may be necessary in the opinion of the Corporation. It shall be incumbent on the Contractor to pay the stamp duty and the legal charges for the preparation of the contract agreement.

GC-20 LIQUIDATED DAMAGES :

If the Contractor fails to complete the work or designated part thereof within the stipulated completion date for the work or for the part, he shall pay liquidated damages at 0.1 (zero point one) percent of contract value for per day of delay subject to maximum of 10% of the contract value or as decided by Municipal Commissioner.

The Contractor shall complete one-sixth quantum of work within one fourth period, four-tenth quantum of work within one-half period and eight-tenth quantum of work within three-fourth period, failing which, the Contractor shall be liable to pay liquidated damages an amount as specified above, or as decided by Municipal Commissioner.

The amount of liquidated damages shall, however, be subjected to a maximum of 10 percent of the contract value.

GC-21 FORFEITURE OF SECURITY DEPOSIT :

Whenever any claim against the Contractor for the payment of a sum of money out of or under the contract arises, the Corporation shall be entitled to recover such sum by appropriating in part or whole, the security deposit of the Contractor. In case the security deposit is insufficient, the balance recoverable shall be deducted from any sum then due or which at any time thereafter may become due to the Contractor. The Contractor shall pay to the owner on demand any balance remaining due.

GC-22 ACTION OF FORFEITURE OF SECURITY DEPOSIT :

In any case in which under any Clause or Clauses of the contract, the Contractor shall committed a breach of any of the terms contained in this contract, the owner shall have power to adopt any of the following courses as he may deem best suited to his interest.

- a) To rescind the contract (of which recession notice in writing to the contractor under the hand of the owner shall be conclusive evidence) in which case the security deposit of the Contractor shall stand forfeited and be absolutely at the disposal of the owner.
- b) To employ labour and to supply materials to carry out the balance work debiting Contractor with the cost of labour employed and the cost of materials supplied for which a certificate of the Engineer-In-Charge shall be final and conclusive against the Contractor and 10% of costs on above to cover all departmental charges and crediting him with the value of work done at the same rates as if it has been carried out by the Contractor under the terms of his contract. The certificate of Engineer-In-Charge as to the value of the work done shall be final and conclusive against the Contractor.
- c) To measure up the work of the contractor and to take such part thereof as shall be unexecuted out of his hand and give it to another Contractor to complete, the same. in this case the excess expenditure incurred than what would have been paid to the original Contractor, if the whole work had been executed by him, shall be borne and paid by the original Contractor and shall be deducted from any money due to him by the owner under the contract or otherwise and for the excess expenditure, the certificate of the Engineer-In-Charge shall be final and conclusive.

In the event any of the above courses being adopted by the owner, ~~the~~ Contractor shall have no claims for compensation for any loss sustained by him by reason of his having purchased or procured any materials or entered into any agreements or made any advance on account of or with a view to the execution of the work or the performance of the contract.

In purchase the Contractor shall not be entitled to recover or be paid any sum for any work actually performed under this contract unless the Engineer-In-Charge will certify in writing the performance of such work and the value payable in respect thereof and he shall only be entitled to be paid the value so certified.

In the event of the owner putting in force the powers as stated in a, b, c, above vested in him under the proceeding clause, he may, if he so desires, take possession of all or any tools and plant, materials and stores in or upon the works or the site thereof belonging to the Contractor, or procured by him and intended to be used for the execution of the work or any part thereof paying or allowing for the same in account at the contract rates to be certified by the Engineer-In-Charge. The Engineer-In-Charge may give notice in writing to the Contractor or his representative requiring him to remove such tools, plant, materials or stores from the premises within the time specified in the notice and in the event of the Contractor failing to comply with any such notice, the Engineer-In-Charge may remove them at the Contractor's expenses or sell them by auction or private sale on account of the Contractor and his risks in all respects without any further notice as to the date, time or place of the sale and the certificate of Engineer-In-Charge as to the expense of any such removal and the amount of the proceeds and the expenses of any such sale shall be final and conclusive against the Contractor.

GC-23

COMPENSATION FOR ALTERATION IN OR RESTRICTION IN WORK :

If at any time from the commencement of the work, the owner shall for any reasons whatsoever not require the whole work or part thereof as specified in the e-Tender to be carried out, the Engineer-In-Charge shall give notice in writing of the fact to the Contractor, who shall have no claim to any payment or compensation whatsoever on account of any profit or advantage which he might have derived from the execution of the work in full but which he did not derive in consequence of full amount of the work not having been carried out. He also shall not have any claim for compensation by reasons of any alterations having been made in original specifications, drawings, designs and instructions which shall involve any curtailment of the work as originally contemplated.

When the Contractor is a partnership firm, the prior approval in writing of the owner shall be obtained before any change is made in the Constitution of the firm. Where the Contractor is an individual or a Hindu Undivided Family or business concern, such approval as aforesaid shall, likewise be obtained before Contractor enters into an agreement with other parties where under, the reconstituted firm would have the right to carry out the work hereby undertaken by the Contractor. In either case, if prior approval as aforesaid is not obtained, the contract shall be deemed to have been allotted contravention of subletting clause hereof and the same action may be taken and the same consequence shall ensure as provided in the subletting clause.

GC-24

IN THE EVENT OF DEATH OF THE CONTRACTOR :

Without prejudice to any of the rights or remedies under the contract, if the Contractor dies, the owner shall have the option of terminating the contract without compensation to the Contractor.

GC-25

MEMBERS OF THE OWNER NOT INDIVIDUALLY LIABLE :

No official or employee of the owner shall in any way be personally bound or liable for the acts or obligation of the owner under the contract, or answerable for any default or omission in the observance or performance of any acts, matters or things, which are herein, contained.

GC-26 OWNER NOT BOUND BY PERSONAL REPRESENTATIONS : 52

The Contractor shall not be entitled to any increase on the schedule of rates or any other rights or claims whatsoever by reason of representation, promise or guarantees given or alleged to have been given to him by any person.

GC-27 CONTRACTOR'S OFFICE AT SITE :

The Contractor shall provide and maintain an office at the site for the accommodation of his agent and staff and such office shall remain open at all reasonable hours to receive information, notices or other communications.

GC-28 CONTRACTOR'S SUBORDINATE STAFF AND THEIR CONDUCT :

1. The Contractor on award of the work shall name and depute a qualified Engineer having experience of carrying out work of similar nature, whom equipments, materials, if any, shall be issued and instructions for work given. the Contractor shall also provide to the satisfaction of Engineer-In-Charge sufficient and qualified staff, competent sub-agents, foreman and loading hands including those specially qualified by previous experience to supervise the type of works comprised in the contract in such manner as will ensure work of the best quality and expeditious working. If, in the opinion of the Engineer-In-Charge additional properly qualified supervision staff is considered necessary, it shall be employed by the Contractor, without additional charge on account thereof. The Contractor shall ensure to the satisfaction of the Engineer-In-Charge that sub-contractors, if any, shall provide competent and efficient supervision over the work entrusted to them.
2. If and whenever any of the Contractor's or sub-contractor's agents, sub-agents, assistants, foreman or other employees shall, in the opinion of the Engineer-In-Charge, be guilty of any misconduct or be incompetent or insufficiently qualified or negligent in the performance of their duties or that in the opinion of the owner or Engineer-In-Charge, it is undesirable for administrative or any other reason for person or persons to be employed in the works, the Contractor if so directed by the Engineer-In-Charge, shall at once remove such person or persons from employment thereon. Any person or persons so removed shall not again be re-employed in connection with the works without the written permission of the Engineer-In-Charge. Any person, so removed from the works shall be immediately replaced at the expense of the Contractor by a qualified and competent substitute. Should the Contractor be required to repatriate any person removed from the works he shall do so after approval of Engineer-In-Charge and shall bear all costs in connection there with.
3. The Contractor shall be responsible for the proper behavior of all the staff, foreman, workmen and others and shall exercise proper control over them and in particular and without prejudice to the said generality, the Contractor shall be bound to prohibit and prevent any employee from trespassing or acting in any way detrimental or prejudicial to the interest of the community or of the properties or occupiers of land and properties in the neighborhood and in the event of such employees so trespassing, the Contractor shall be responsible therefore and relieve the owner of all consequent claims, actions for damages or injury or any other ground whatsoever. The decision of the Engineer-In-Charge upon any matter arising under this claim shall be final.
4. If and when required by the owner, the Contractor's personnel entering upon the owner's premises shall be properly identified by badges of a type acceptable to the owner which must be worn at all times on owner's premises.

If any sub-contractor engaged upon the works at the site execute any work which in the opinion of Engineer-In-Charge is not accordance with the contract documents, the owner may by written notice to the Contractor request him to terminate such sub-contract and the Contractor upon the receipt of such notice shall terminate such sub-contracts and the latter shall forthwith leave the works, failing which, the owner shall have the right to remove such sub-contractors from the site.

No action taken by the owner under the above clause shall relieve the Contractor of his liabilities under the contract or give rise to any right to compensation, extension of time or otherwise.

POWER OF ENTRY :

If the Contractor shall not commence the work in the manner previously described in the contract documents or if he shall at any time, in the opinion of Engineer-In-Charge –

- i) Fail to carry out works in conformity with the contract documents, or
- ii) Fail to carry out the works in accordance with the time schedule, or
- iii) Substantially suspend work or the works for a period of seven days without authority from Engineer-In-Charge, or
- iv) Fail to carry out and execute the work to the satisfaction of the Engineer-In-Charge, or
- v) Fail to supply sufficient or suitable construction plant, temporary works, labour, materials or things, or
- vi) Commit breach of any other provisions of the contract on his part to be performed or observed or persists in any of the above mentioned breaches of the contract for seven days after notice in writing shall have been given to the Contractor by the Engineer-In-Charge requiring such breach to be remedied, or
- vii) Abandon the work, or
- viii) During the continuance of the contract becomes bankrupt, make any arrangement or compromise with his creditors, or permit any execution to be levied or go into liquidation whether compulsory or voluntary not being merely a voluntary liquidation for the purpose of amalgamation or reconstruction then in any such case.

The owner shall have the power to enter upon the works and take possession thereof and of the materials, temporary works, constructional plant and stores therein and to revoke the Contractor's license to use the same and to complete the works by his agents, other Contractor or workmen, to relate the same upon any terms to such other person firm or Corporation as the owner in his absolute discretion may think proper to employ, and for the purpose aforesaid to use or authorize the use of any materials, temporary works, constructional plant, and stores as aforesaid with making payments or allowance to the Contractor for the said materials other than such as may be certified in writing by the Engineer-In-Charge to be reasonable and without making any payment or allowance to the Contractor for the use of said temporary works, constructional plant and stock or being liable for loss or damage thereto. If the owner shall be reason of his taking possession of the works or of the work being got completed by other Contractor incurred excess expenditure be deducted from any money which may be due for the work done by the Contractor under the contract and not paid for. Any deficiency shall forthwith be made good and paid to the owner by the Contractor and the owner shall have power to sell in such manner and for such price as he may think fit all or any of the constructional plant, materials etc., consist constructed by or belonging to and to recoup and retain the said deficiency or any part thereof out of the proceeds of the sale.

GC-31 CONTRACTOR'S RESPONSIBILITY WITH THE OTHER CONTRACTOR AND AGENCIES :

Without repugnance to any other conditions, it shall be the responsibility of the Contractor executing the work, to work in close co-operation and co-ordination with other Contractors or their authorized representatives and the Contractor will put a joint scheme with the concurrence of other contractors or their authorized representatives showing the arrangements for carrying his portion of the work to the Engineer-In-Charge and get the approval. The Engineer-In-Charge before approving the joint scheme will call the parties concerned and modify the scheme if required. No claim will be entertained on account of the above. The Contractor shall conform in all respects with the provisions of any statutory regulations, ordinances or bylaws of any local or duly constituted authorities or public bodies which may be applicable from time to time to works or any temporary works. The Contractor shall keep the owner indemnified against all penalties and liabilities of every kind arising out of non-adherence to such statutes, ordinance, laws, rules, regulations etc.

GC-32 OTHER AGENCIES AT SITE :

The Contractor shall have to execute the work in such place and condition where other agencies will also be engaged for other works, such as site grading, filling and leveling, electrical and mechanical engineering works etc. No claim shall be entertained for works being executed in the above circumstances.

GC-33 NOTICES :

Any notice under this contract may be served on the Contractor or his duly authorized representative at the job site or may be served by Registered Post direct to the official address of the Contractor. Proof of issue of any such notice could be conclusive of the Contractor having been duly informed of all contents therein.

GC-34 RIGHTS OF VARIOUS INTERESTS :

The owner reserves the right to distribute the work between more than one Contractor. Contractor shall co-operate and afford reasonable opportunity to other Contractor s for access to the works, for the carriage and storage of materials and execution of their works. Whenever the work being done by department of the owner or by other Contractor employed by the owner is contingent upon work covered by this contract, the respective rights of the various interests shall be determined by the Engineer-In-Charge to secure the completion of various portions of the work in general harmony.

GC-35 PRICE ADJUSTMENTS :

No adjustment in price shall be allowed and no price escalation will be allowed.

GC-36 TERMS OF PAYMENT :

The payment of bills shall be made progressively according to the rules and practices followed by the Corporation. The progressive payment unless otherwise provided in the contract agreement or subsequently agreed to by the parties shall be made generally monthly on submission of a bill by the Contractor in prescribed form of an amount according to the value of the work performed less the price of materials supplied by owner aggregate of previous progressive payments and as required by Clause GC-37 (Retention of Money) herein. All such progressive payments shall be regarded as payments by way of advance against final payment. Payment for the work done by the Contractor will be based on the measurement at various stages of the work, in accordance with the condition at clause GC-81 (measurement of work in progress).

- a) If in the opinion of the Corporation, the Contractor fails to make completion of works within the time specified in the completion schedule or within the period for which extension has been granted by the Corporation to the Contractor.
 - b) If in the opinion of the Corporation, the Contractor fails to comply with any of the other provisions of this contract.
- ii) In the event, the Corporation terminates the contract in whole or in part as provided in Article GC-50 (Termination of the Contract) the Corporation reserves the right to purchase upon such terms and in such manner as it may be deem appropriate, plant similar to one which is not supplied by the Contractor and the Contractor will be liable to the Corporation for any additional costs for such similar plant and / or for liquidated damages for delay until such time as may be required for the final completion of works.
- iii) If this contract is terminated as provided in this paragraph GC-40 AND/OR GC-30 (Power of Entry) (1) the Corporation in addition to any other rights provided in this clause, may require the Contractor to transfer title and deliver to the Corporation.
- a) Any completed works
 - b) Such partially completed information and contract rights as the Contractor has specifically produced or acquired for the performance of the contract so terminated.
- iv) In the event, the Corporation does not terminate the contract as provided in the paragraph GC-50 (Termination of Contract) the Contractor shall continue performance of the contract, in which case, he shall be liable to the Corporation for liquidated damages for delay until the works are completed and accepted.

GC-42

BANKRUPTCY :

If the Contractor shall become bankrupt or insolvent or has a receiving order made against him, or compound with his creditors, or being the Corporation commence to be wound up not being a member voluntary winding up for the purpose of amalgamation or reconstruction, or carry on its business under a receiver for the benefit of his creditors or any of them, the Corporation shall be at liberty to either (a) terminate the contract forthwith by giving notice in writing to the Contractor or to the receiver or liquidator or to any person or Organization in whom the contract may become vested and to act in the manner provided in Article GC-41 (Default of Contractor) as though the last mentioned notice had been the notice referred to in such article or (b) to give such receiver, liquidator or other persons in whom the contract may become vested the option of carrying out the contract subject to his providing a satisfactory guarantee for the due and faithful, performance of the contract up to an amount to be agreed. In the event that the Corporation terminates the contract in accordance with this article, the performance bond shall immediately become due and payable on demand to Corporation.

GC-43

OWNERSHIP :

Works hand over pursuant to the contract shall become the property of the Corporation from whichever is the earlier of the following times, namely;

- a) When the works are completed pursuant to the contract.
- b) When the contractor has been paid any sum to which he may become entitled in respect thereof pursuant to Clause GC-36 (Terms of Payment).

GC-44

DECLARATION AGAINST WAIVER :

The condemnation by the Corporation of any breach or breaches by the Contractor or an authorized sub-contractor of any of the stipulations and conditions contained in the contract, shall in no way prejudice or affect or be construed as a waiver of the Corporation's rights, powers and remedies

- GC-45 LAWS GOVERNING THE CONTRACT :
This contract shall be construed according to and subject to the laws of India and the State of Gujarat and under the jurisdiction of the Courts of Gujarat at Rajkot.
- GC-46 OVER PAYMENT AND UNDER PAYMENT :
Whenever any claim for the payment of a sum to the Corporation arises out of or under this contract against the Contractor, the same may be deducted by the Corporation from any sum then due or which at any time thereafter may become due to the Contractor under this contract and failing that under any other contract with the Corporation (which may be available with the Corporation), or from his retention money or he shall pay the claim on demand. The Corporation reserves the right to carry out post payment audit and technical examinations of the final bill including all supporting vouchers, abstracts etc. The Corporation further reserves the right to enforce recovery of any payment when detected, notwithstanding the fact that the amount of the final bill may be included by one of the parties as an item of dispute before an Arbitrator, appointed under Article GC-49 (Arbitration) of this contract and notwithstanding the fact that the amount of the final bill figures in the arbitration award. If as a result of such audit and technical examinations any over payment is discovered in respect of any work done by the Contractor or alleged to have been done by him under the contract, it shall be recovered by the Corporation from the Contractor as prescribed above. If any under payment is discovered by the Corporation, the amount due to the Contractor under this contract, may be adjusted against any amount then due or which may at any time thereafter become due before payment is made to the Contractor.
- GC-47 SETTLEMENT OF DISPUTES :
Except as otherwise specifically provided in the contract, all disputes concerning questions of fact arising under the contract shall be decided by the Engineer-In-Charge subject to a written appeal by the Contractor to the Engineer-In-Charge and those decisions shall be final and binding on the parties hereto. Any disputes or differences including those considered as such by only one of the parties arising out of or in connection with this contract shall be to the extent possible settled amicably between the parties. If amicable settlement cannot be reached then all disputed issues shall be settled as provided in Article GC-48 (Disputes or differences to be referred to) and Article No.GC-49 (Arbitration).
- GC-48 DISPUTES OF DIFFERENCES TO BE REFERRED TO :
If at any time, any question, disputes or differences of any kind whatsoever shall arise between the Engineer-In-Charge and the contractor upon or in relation to or in connection with this contract either party may forthwith give to the other, notice in writing of the existence of such question, dispute or difference as to any decision, opinion, instruction, direction, certificate or evaluation of the Engineer-In-Charge. The question, dispute or differences shall be settled by the Municipal Commissioner, Rajkot Municipal Corporation, who shall state his decision in writing and give notice of same to the Engineer-In-Charge and to the Contractor. Such decision shall be final and binding upon both parties. The contract and work on contract if not already breached or abandoned shall proceed normally unless and until the same shall be revised (or uphold) by any arbitration proceedings as hereinafter provided. Such decisions shall be final and binding on the Engineer-In-Charge and the Contractor unless the Contractor shall require the matter to be referred to an Arbitration panel as hereinafter provided.
- GC-49 ARBITRATION :
In case of any dispute arising during the course of execution, the matter should be referred to Municipal Commissioner who will be sole Arbitrator whose decisions will be final and binding to the Contractor.

The word "Arbitration" or "Arbitration Clause" wherever mentioned in ~~58~~ tender document, is to be treated to be referred to GC-49. In this context, an Order bearing No.RMC/Legal/1858 dated 18-02-2017 of Legal Department of Rajkot Municipal Corporation is uploaded separately along with this tender, which Order, will hereafter referred and taken into consideration for Arbitration related purpose.

GC-50

TERMINATION OF THE CONTRACT :

- i) If the Contractor finds it impracticable to continue operation owing to force majeure reasons or for any reasons beyond his control and/or the Corporation find it impossible to continue operation, then prompt notification in writing shall be given by the party affected to the other.
- ii) If the delay or difficulties so caused cannot be expected to cease or become unavoidable or if operations cannot be resumed within two (2) months then either party shall have the right to terminate the contract upon ten (10) days written notice to the other. In the event of such termination of the contract, payment to the Contractor will be made as follows :
 - a) The Contractor shall be paid for all works approved by the Engineer-In-Charge and for any other legitimate expenses due to him.
 - b) If the Corporation terminates the contract owing to Force Majeure or due to any cause beyond its control, the Contractor shall additionally be paid for any work done during the said two (2) months period including any financial commitment made for the proper performance of the contract and which are not reasonably defrayed by payments under (a) above.
 - c) The Corporation shall also release all bonds and guarantees at its disposal except in cases where the total amount of payment made to the Contractor exceeds the final amount due to him in which case the Contractor shall refund the excess amount within thirty (30) days after the termination and the Corporation thereafter shall release all bonds and guarantees. Should the Contractor fail to refund the amounts received in excess within the said period such amounts shall be deducted from the bonds or guarantees provided.
- iii) On termination of the contract for any cause the Contractor shall see the orderly suspension and termination of operations, with due consideration to the interests of the Corporation with respect to completion safeguarding of storing materials procured for the performance of the contract and the salvage and resale thereof.

GC-51

SPECIAL RISKS :

If during the contract, there shall be an outbreak of war (whether war is declared or not), major epidemic, earthquake or similar occurrence in any part of the world beyond the control of either party to the contract which financially or otherwise materially affects the execution of the contract, the Contractor shall unless and until, the contract is terminated under the provisions of this article use his best endeavors to complete the execution of the contract, provided always that the Corporation shall be entitled at any item after the onset of such special risks, to terminate the contract by giving written notice to the contractor and upon such notice being given this contract shall terminate but without prejudice to the rights of either party in respect of any antecedent breach thereof.

The Contractor shall not be liable for payment of compensation for delay or for failure to perform the contract for reasons of Force Majeure such as acts of public enemy, acts of Government, fires, floods, cyclones, epidemics, quarantine restrictions, lockouts, strikes, freight embargoes and provided that the Contractor shall within 10 (ten) days from the beginning of such delay notify the Engineer-In-Charge in writing, of the cause of delay, the Corporation shall verify the facts and grant such extension as the facts justify.

GC-52 CHANGE IN CONSTITUTION :

Where the Contractor is a partnership firm, the prior approval in writing of the owner shall be obtained before any change is made in the constitution of the firm. Where the Contractor is an individual or undivided family business concern such approval as aforesaid shall likewise be obtained before the Contractor enters into any partnership agreement where under the partnership firm would have the right to carry out the works hereby undertaken by the Contractor. If prior approval as aforesaid is not obtained, the contract shall be deemed to have been assigned in contravention of contract.

GC-53 SUB-CONTRACTUAL RELATIONS :

All works performed for the contract by a sub-contractor shall be pursuant to an appropriate agreement between the Contractor and the sub-contractor, which shall contain provision to –

- a) Protect and preserve the rights of the Corporation and the Engineer-In-Charge with respect to the works to be performed under the sub-contracting party will not prejudice such rights.
- b) Require that such work be performed in accordance with the requirements of contract documents.
- c) Require under such contract to which the contractor is a party, the submission to the Contractor of application for payment and claims for additional costs, extension of time, damages for delay or otherwise with respect to the sub-contracted portions of the work in sufficient time, that the Contractor may apply for payment comply in accordance with the contract documents for like claims by the Contractor upon the Corporation.
- d) Waive all rights the contracting parties may have against one another for damages caused by fire or other perils covered by the property insurance except such rights as they may have to the proceeds of such insurance held by the Corporation as trustee and,
- e) Obligate each sub-contractor specifically to consent to the provisions of this Article.

GC-54 PATENTS AND ROYALTIES :

1. Contractor, if licensed under any patent covering equipment, machinery, materials or composition of matter to be used or supplied or methods and process to be practiced or employed in the performance of this contract agrees to pay all royalties and license fees, which may be due with respect thereto. If any equipment, machinery, materials, composition matters, to be used or supplied or methods practiced or employed in the performance of this contract, is covered by a patent under which Contractor is not licensed, then the Contractor before supplying / using the equipment, machinery, materials, compositions, methods of process shall obtain such license and pay such royalties and license fees as may be necessary for performance of this contract. In the event Contractor fails to pay such royalty or to obtain any such license, any suit for infringement of such patents which is brought against the Contractor or the owner as a result of such failure will be defended by the Contractor at his own expenses and the Contractor will pay any damages and costs awarded in such suit. The Contractor shall promptly notify the owner if the Contractor has acquired knowledge of any plant under which a suit for infringement could be reasonably brought because of the use by the owner of any equipment machinery, materials, process methods to be supplied in hereunder. Contractor agrees to and does hereby grant to owner together with the right to extend the same to any of the subsidiaries of the owner an irrevocable royalty fee license to use in any Country, any invention made by the Contractor or his employees in or as a result of the performance of work under contract.

2. With respect to any sub-contract entered into by Contractor pursuant to the provisions of the relevant clause hereof, the Contractor shall obtain from the sub-contractor an understanding to provide the owner with the

same patent protection that contracts is required to provide under the provisions of the clause.

3. The Contractor shall indemnify and save harmless the owner from any loss on account of claims against owner for the contributory infringement of patent rights arising out of and based upon the claim that the use by the Corporation of the process included in the design prepared by the Contractor and used in the operation of the plant infringes on any patent rights.

GC-55 LIEN :

If, at any time, there should be evidence of any lien or claim for which owner might have become liable and which is chargeable to the Contractor, the owner shall have the right to retain out of any payment then due or thereafter to become due an amount sufficient to completely indemnify the owner against such lien or claim or if such lien or claim be valid the owner may pay and discharge the same and deduct the amount as paid from any money which may be due or become due and payable to the Contractor. If any lien or claims remaining unsettled after all payments are made, the Contractor shall refund or pay to the owner all money that the latter may be compelled to pay in discharging such lien or claim including all costs and reasonable expenses.

GC-56 EXECUTION OF WORK :

The whole work shall be carried out in strict conformity with the provisions of the contract document, detailed drawings, specifications and the instructions of the Engineer-In-Charge from time to time. The Contractor shall ensure that the whole work is executed in the most substantial, and proper manner with best workmanship using materials of best quality in strict accordance with the specifications to the entire satisfaction of the Engineer-In-Charge.

GC-57 WORK IN MONSOON :

When the work continues in monsoon if required, the Contractor shall maintain minimum labour force required for the work and plan and execute the construction and erection work according to the prescribed schedule. No extra rate will be considered for such work in monsoon. During monsoon and entire construction period, the Contractor shall keep the site free from water at his own cost. However, monsoon period from 1st July to 30th September will be excluded in time limit.

GC-58 WORK ON SUNDAYS AND HOLIDAYS :

No work except curing shall be carried out on Sunday and holidays. However, if the exigencies of the work need continuation of work on Sundays and Holidays, written permission of the Engineer-In-Charge shall be obtained in advance.

GC-59 GENERAL CONDITIONS FOR CONSTRUCTION WORK :

Working hours shall be eight every day. The overtime work in two shifts could be carried out with the written permission of the Engineer-In-Charge but no compensation shall be paid for the same. The rate quoted shall include this. The Contractor shall plan his work in such a way that his labourers do not remain idle. The owner will not be responsible for idle labour of the Contractor. The Contractor shall submit to the owner progress report every week. The details and proforma of the report will be as per mutual agreement.

GC-60 DRAWINGS TO BE SUPPLIED BY THE OWNER : (N.A.)

The drawings attached with the e-Tender documents shall be for general guidance of the Contractor to enable him to visualize the type of work contemplated and scope of work involved. Detail working drawings according to which the work is to be done shall be prepared by the Contractor for executing the work.

GC-61

DRAWINGS TO BE SUPPLIED BY THE CONTRACTOR:

61

Where drawings, data are to be furnished by the Contractor they shall be as enumerated in special conditions of contract and shall be furnished within the specified time. Where approval of drawings has been specified it shall be Contractor's responsibility to have these drawings got approved before any work is taken up with regard to the same. Any changes becoming necessary in those drawings during the execution of the work shall have to be carried out by the Contractor at no extra cost. All final drawings shall bear the certification stamp as indicated below duly signed by both the Contractor and Engineer-In-Charge.

Certified true for Project Agreement No.....

Signed

Contractor Engineer-In-Charge
Drawings will be approved within three (3 weeks of the receipt of the same by the Engineer-In-Charge.

GC-62

SETTING OUT WORK :

The Contractor shall set out the work on the site handed over by the Engineer-In-Charge and shall be responsible for the correctness of the same. The work shall be carried out to the entire satisfaction of Engineer-In-Charge. The approval thereof or partaking by Engineer-In-Charge or setting out work shall not relieve Contractor of any of his responsibilities. The Contractor shall provide at his own cost all necessary level posts, pegs, bamboos, flags, ranging rods, strings and other materials and labourers required for proper setting out of the work. The Contractor shall provide fix and be responsible for the maintenance of all stakes, templates, level markets, profiles and similar other things and shall take all necessary precautions to prevent their removal or disturbance and shall be responsible for the consequences for such removal or disturbance. The Contractor shall also be responsible for the maintenance of all existing survey marks, boundary marks, and distance marks and centerline marks either existing or face lines and cross lines shall be marked by small masonry pillars. Each pillar shall have distance mark at the center for setting up the theodolite. The work shall not be started unless the setting out is choked and approved by Engineer-In-Charge in writing but such approval shall not relieve the Contractor of his responsibilities about the correctness of setting out. The Contractor shall provide all materials, labour and other facilities necessary for checking at his own cost. Pillars bearing geodetic marks on site shall be protected by the Contractor. On completion of the work, the Contractor shall submit the geodetic documents according to which the work has been carried out.

GC-63

RESPONSIBILITIES OF CONTRACTOR FOR CORRECTNESS OF THE WORK :

The Contractor shall be entirely and exclusively responsible for the correctness of every part of the work and shall rectify completely any errors therein at his own cost when so instructed by Engineer-In-Charge. If any error has crept in the work due to non-observance of this clause, the Contractor will be responsible for the error and bear the cost of corrective work.

1.

Materials to be supplied by the Contractor:
Contractor shall procure and provide all the material required for the execution and maintenance of work including M S rods; all tools, tackles, construction plant and equipment except, the materials to be supplied by the owner detailed in the contract documents. Owner, shall make recommendations for procurement of materials to the respective authorities if desired by the Contractor but assumes no responsibility of any nature. Owner shall insist for procurement of materials with ISI

2. If however, the Engineer-In-Charge feels that the work is likely to be delayed due to Contractor's inability to procure materials, the Engineer-In-Charge shall have the right to procure materials, from the market and the Contractor will accept these materials at the rates decided by Engineer-In-Charge.

GC-64 MATERIALS TO BE SUPPLIED BY THE OWNER :

1. If the contract provided certain materials or stores to be supplied by the owner, such materials and stores transported by the Contractor at his cost from owner's stores or Railway Station. The cost from Contractor for the value of materials supplied by the owner will be recovered from the R.A.Bill on the basis of actual consumption of materials in the work covered and for which R A Bill has been prepared. After completion of the work, the Contractor has to account for the full quantity of materials supplied to him.
2. The value of store materials supplied by owner to the Contractor shall be charged at rates shown in the contract document and in case any other material not listed in the schedule of materials is supplied by the owner, the same shall be charged at cost price including carting and other expenses incurred in procuring the same. All materials so supplied shall remain the property of the owner and shall not be removed from the site on any account. Any material remaining unused at the time of completion of work or termination of contracts shall be returned to owner's store or any other place as directed by the Engineer-In-Charge in perfectly good condition at Contractor's cost. When materials are supplied free of cost for use in work and surplus and unaccounted balance thereof are not returned to the owner, recovery in respect of such balance will be effected at double the applicable issue rate of the material or the market rates whichever is higher.

GC-65 CONDITIONS OF ISSUE OF MATERIALS BY THE OWNER: (N.A.)

The materials specified to be issued by the owner to the Contractor shall be issued by the owner at his store and all expenses for it carting site shall be borne by the Contractor will be issued during working hours and as per rules of owner from time to time.

Contractor shall bear all expenses for storage and safe custody at site of materials issued to him before use in work.

Material shall be issued by the owner in standard / non-standard sizes as obtained from manufacturer.

Contractor shall construct suitable godowns at site for storing the materials to protect the same from damage due to rain, dampness, fire, theft etc.

The Contractor should take the delivery of the materials issued by the owner after satisfying himself that they are in good condition. Once the materials are issued, it will be the responsibility of the Contractor to keep them in good condition and in safe custody. If the materials get damaged or if they are stolen, it shall be the responsibility of the Contractor to replace them at his cost according to the instructions of the Engineer-In-Charge.

For delay in supply or for non-supply of materials to be supplied by the owner, on account of natural calamities, act of enemies, other difficulties beyond the control of the owner, the owner carries no responsibilities. In no case the Contractor shall be entitled to claim any compensation for loss suffered by him on this account.

None of the materials issued to the contractor, shall be used by the Contractor for manufacturing items which can be obtained from the

manufacturer's. The materials issued by the owner shall be used for ~~the~~ work only and no other purpose.

Contractor shall be required to execute indemnity bond in the prescribed form for the safe custody and account of materials issued by the owner.

Contractor shall furnish sufficiently in advance a statement of his requirements of quantities of materials to be supplied by the owner and the time when the same will be required for the work, so as to enable Engineer-In-Charge to make arrangements to procure and supply the materials.

A daily account of materials issued by the owner shall be maintained by the contractor showing receipt, consumption and balance on hand in the form laid down by Engineer-In-Charge with all connected paper and shall be always available for inspection in the site office.

Contractor shall see that only the required quantities of materials are got issued and no more. The Contractor shall be responsible to return the surplus materials at owner's store at his own cost.

GC-66 MATERIALS PROCURED WITH ASSISTANCE OF THE OWNER :
Notwithstanding anything contained to the contrary in any of the clauses of this contract, where any materials for the execution of the contract are procured with the assistance of the owner either by issue from owner's stock or purchase made under orders or permits or licenses issued materials as trustees for owner, and use such materials not disposed them off without the permission of owner and unserviceable materials that may be left with him after completion of the contract or at its termination for any reason whatsoever on his being paid or credited such price as Engineer-In-Charge shall determine having due regard to the conditions of the materials. The price allowed to Contractor shall not exceed the amount charged to him excluding the storage of breach of the aforesaid condition, the Contractor shall in terms of license or permits and/or for criminal breach of trust be liable to compensate owner at double the rate or any higher rates. In the event of these materials at that time having higher rate or not being available in the market then any other rate to be determined by the Engineer-In-Charge at his decision shall be final and conclusive.

GC-67 MATERIALS OBTAINED FROM DISMANTLING :
If the Contractor, in the course of execution of work, is called upon to dismantle any part of work for reasons other than on account of bad or imperfect work, the materials obtained from dismantling will be property of the owner and will be disposed off as per instructions of Engineer-In-Charge in the best interest of the owner.

GC-68 ARTICLE OF VALUE OF TREASURE FOUND DURING CONSTRUCTION :
All gold, silver and other minerals of any description and all precious stones, coins, treasures, relics, antiques and other similar things which shall be found in, under or upon site shall be the property of the owner and the Contractor shall properly preserve the same to the satisfaction of the Engineer-In-Charge and shall hand over the same to the owner.

GC-69 DISCREPANCIES BETWEEN INSTRUCTIONS:
If there is any discrepancy between various stipulations of the contract documents or instructions to the Contractor or his authorized representative or if any doubt arises as to the meaning of such stipulation or instructions, the Contractor shall immediately refer in writing to the Engineer-In-Charge and shall hand over the same to the owner.

GC-70

ALTERATIONS IN SPECIFICATIONS & DESIGNS & EXTRA WORK :64

The Architect / Engineer-In-Charge shall have power to make any alterations in, omission from, addition to substitution for, the schedule of rates, the original specifications, drawings, designs and instructions that may appear to him to be necessary or advisable during the progress of work and the Contractor shall be bound to carry out such altered / extra / new items of work in accordance with any instructions which may be given to him in writing signed by Engineer-In-Charge and such alteration omissions, additions or substitutions, shall not invalidate contract and any altered, additional or substituted work shall be carried out by the Contractor on the same conditions of contract. The time of completion may be extended by Architect as may be considered just and reasonable by him. The rates for such additional, altered or substitute work shall be worked out as under :

- a) If the rates for additional, altered or substitutes work are specified in the contract for work, the Contractor is bound to carry out such work at the same rates as specified in the contract.
- b) If the rates for additional, altered or substituted work are not specifically provided in the contract for the work, the rates will be derived from the rates of similar items of work in the contract work. The opinion of Engineer-In-Charge as to whether the rates can be reasonably so derived the items of contract will be final and binding to the Contractors.
- c) If the rates of altered, additional or substitute work cannot be determined as specified in (a) or (b) above, the rate shall be paid as per S.O.R. of RMC and if not available in RMC SOR than it will be paid according to SOR of R&B/GWSSB.
- d) If the rates of altered, additional or substitute work cannot be determined as specified in (a) or (b) or (c) above, the Contractor shall within seven days of the receipt of order to carry out the work inform the Architect / Engineer-In-Charge of the rate which he intends to charge for such work supported by rate analysis and the Architect / Engineer-In-Charge will determine the rate on the basis of prevailing market rates of materials, labour cost at schedule of labour plus 15% there on as Contractor's supervision overheads and profit. The opinion of Architect / Engineer-In-Charge as to the market rates of materials and the quantity of labour involved per unit of measurement will be final and binding on Contractor.

But under no circumstances, the Contractor suspends work or the plea of non settlement of items falling under this clause.

GC-71

ACTION WHEN NO SPECIFICAITONS ARE ISSUED :

In case of any class of work for which no specifications is supplied by the owner in the e-Tender documents, such work shall be carried out in accordance with relevant latest ISS and if ISS do not cover the same, the work shall be carried out as per General Technical Specification for building work; and if not covered in then it is to be with standard Engineering Practice subject to the approval of Engineer-In-Charge.

GC-72

ABNORMAL RATES :

Contractor is expected to quote rate for each item after careful analysis of cost involved for the performance of the completed item considering all specifications and conditions of contract.

GC-73

ASSISTANCE TO ENGINEER-IN-CHARGE:

Contractor shall make available to Engineer-In-Charge free of cost all necessary instruments and assistance in checking of any work made by the Contractor setting out for taking measurement of work etc.

1. All workmanship shall be of the best kind described in the contract documents and in accordance with the instructions of Engineer-In-Charge and shall be subjected from time to time to such tests at Contractor's cost as the Engineer-In-Charge may direct at the place of manufacture of fabrication or on the site or at any such place. Contractor shall provide assistance, instruments, labour and materials as are normally required for examining, measuring and testing of any work of workmanship as may be selected and required by Engineer-In-Charge.
2. All tests necessary in connection with the execution of work as decided by Engineer-In-Charge shall be carried out at an approved laboratory at Contractor's cost.
3. Contractor shall furnish the Engineer-In-Charge for approval when requested or if required by the specification, adequate samples of all materials and finished goods to be used in work sufficiently in advance to permit tests and examination thereof. All materials furnished and finished goods applied in work shall be exactly as per the approved samples.

ACTION AND COMPENSATION IN CASE OF BAD WORKMANSHIP :

If it shall appear to the Engineer-In-Charge that any work has been executed with materials of inferior description, or quality or are unsound or with unsound, imperfect or unskilled workmanship or otherwise not in accordance with the contract, the Contractor shall, on demand in writing from Engineer-In-Charge or his authorized representative specifying the work, materials or articles complained of, notwithstanding that the same may have been inadvertently passed, certified and paid for, forthwith rectify or remove and reconstruct the work, so specified. In the event of failure to do so within a period to be specified by the Engineer-In-Charge in his aforesaid demand, Contractor shall be liable to pay compensation at the rate of half a percent of the estimated cost of work for every work limited to a maximum of ten (10%) percent of the value of work while his failure to do so continues and in the case of any such failure, the Engineer-In-Charge may on expiry of the notice period rectify and remove and re-execute the work or remove and replace with others at the risk and cost of the Contractor. The decision of the Engineer-In-Charge as to any question arising under this clause shall be final and conclusive.

SUSPENSION WORK :

Contractor shall, if ordered in writing by Engineer-In-Charge or his representative temporarily suspended the work or any part thereof for such time (not exceeding one month) as ordered and shall not after receiving such written notice proceed with the work until he shall have received a written order to proceed therewith. The Contractor shall not be entitled to claim compensation for any loss or damage sustained by him by reason of temporary suspension of work as aforesaid. An extension of time for completion of work will be granted to the Contractor corresponding to the delay caused by such suspension of work if he applies for the same provided the suspension was not consequent upon any default or failure on the part of the Contractor.

OWNER MAY DO PART OF THE WORK :

When the Contractor fails to comply with any instructions given in accordance with the provisions of this contract, the owner has the right to carry out such parts of work as the owner may designate whether by purchasing materials and engaging labour or by the agency of another Contractor. In such case the owner shall deduct from the amount which otherwise might become due to Contractor, the cost of such work and materials with then (10) percent added to cover all departmental charges and should the total amount thereof exceed the amount due to contract, Contractor shall pay the difference to owner.

The Engineer-In-Charge shall have the right to take possession of or to use any completed or partly completed work or part of work. Such possession or use shall not be deemed to be an acceptance of any work completed in accordance with the contract. If such prior possession or use by Engineer-In-Charge delays the process of work, equitable adjustment in the time of completion will be made and the contract shall be deemed to be modified accordingly.

COMPLETION CERTIFICATE :

As soon as the work has been completed in accordance with contract (except in minor respects that do not effect their use for the purpose for which they are intended and except for maintenance thereof) as per General Conditions of Contract the Engineer-In-Charge shall issue a certificate (hereinafter called completion certificate) in which shall certify the date on which work has been completed and has passed the said tests and owner shall be deemed to have taken over work on the date so certified. If work has been divided in various groups in contract, owner shall be entitled to take over any group or groups before the other or others and there upon the Engineer-In-Charge will issue a completion certificate, which will, however, be for such group or groups so taken over.

In order that Contractor could get a completion certificate, he shall make good will all speed any defect arising from the defective materials supplied by Contractor of workmanship or any act or omission of Contractor that may have been discovered or developed after the work or groups of works has been taken over. The period allowed for carrying out such work will be normally, one month. If any defect be not remedied within the time specified, owner may proceed to do work at Contractor's (Agency, or Firm) risk and expenses and deduct from the final bill such amount as may be decided by owner. If by reason of any default on the part of the Contractor, a completion certificate has not been issued in respect of every portion of work within one month after the date fixed by contract for completion of work, owner shall be at liberty to use work or any portion thereof in respect of which a completion certificate has been issued, provided that work or the portion thereof so used as aforesaid shall be afforded reasonable opportunity for completion of that work or the portion thereof so used as aforesaid shall be afforded reasonable opportunity for completion of that work for the issue of completion certificate.

SCHEDULE OF RATES :

1. The rates quoted by the Contractor shall remain firm till the completion of the work and shall not be subject to escalation. Schedule of rates shall be deemed to include and cover all costs, expenses and liabilities of every description and risks or every kind to be taken in executing, completing and handing over the work to owner by Contractor. The contractor shall be deemed to have known the nature, scope, magnitude and the extent of work and materials required though contract documents may not fully and precisely furnish them. He shall make such provision in the Schedule of Rates as he may consider necessary to cover the cost of such items of work and materials as may be reasonable and necessary to complete the work. The opinion of Engineer-In-Charge as to the item of work which are necessary and reasonable for completion of the work shall be final and binding on Contractor although the same may be not shown on drawings or described specifically in contract documents.
2. The Schedule of Rates shall be deemed to include and cover the cost of all constructional plant, temporary work, materials, labour and all other matters in connection with each item in Schedule of Rates and the execution of work or any portion thereof finished complete in every respect and maintained as shown or described in the contract document or as may be ordered in writing during the continuance of the contract.

3. The Schedule of Rates shall be deemed to include and cover the cost of all royalties and fees for the articles and processes, protected by letters patent or otherwise incorporated in or used in connection with work, also all royalties, rents and other payments in connection with obtaining material of whatsoever kind for work and shall include an indemnity to owner which Contractor hereby gives against all action, proceedings, claims, damages, costs and expenses arising from the incorporation in or use on the works of any such articles, processes or materials. Other Municipal or local Board charges if levied on material, equipment or machineries to be brought to site for use on work shall be borne by the Contractor.
4. No exemption or reduction of custom duties, excise duties, sales tax or any other taxes or charges of the Central or State Government or of any Local Body whatsoever will be granted or obtained and all such expenses shall be deemed to have been included in and covered by Schedule of Rates. Contractor shall also obtain and pay for all permits or other privileges necessary to complete the work.
5. The Schedule of Rates shall be deemed to include and cover risk on account of delay and interference with Contractor's conduct of work which may occur from any cause including orders of owner in the exercise of his powers and on account of extension of time granted due to various reasons.
6. For work under unit rate basis, no alteration will be allowed in the Schedule of Rates by reasons of work or any part of them being modified, altered, extended, diminished or omitted.

GC-81 **PROCEDURE FOR MEASUREMENT OF WORK IN PROGRESS:**

1. All measurements shall be in metric system. All the work in progress will be jointly measured by the representative of Engineer-In-Charge and Contractor's authorized agent. Such measurements will be got recorded in the Measurement Book by the Engineer-In-Charge or his authorized representative and signed by the Contractor or his authorized agent in token of acceptance. If the Contractor or his authorized agent fails to be present whenever required by the Engineer-In-Charge for taking measures for every reasons whatsoever, the measurement will be taken by the Engineer-In-Charge or his authorized representative notwithstanding the absence of Contractor and these measurements will be deemed to be correct and binding on the Contractor.
2. Contractor will submit a bill in approved proforma in quadruplicate to the Engineer-In-Charge of the work giving abstract and detailed measurements of various items executed during a month as mutually agreed. The Engineer-In-Charge shall verify the bill and the claim, as far as admissible, adjusted if possible, within 10 days of presentation of the bills.

GC-82 **RUNNING ACCOUNT PAYMENTS TO BE REGARDED AS ADVANCES :**

1. All running account payments shall be regarded as payments by way of advance against the final payment only and not as payment for work actually done and completed and shall not preclude the requiring of bad, unsound and imperfect or unskilled work to be removed and taken away and reconstructed or rejected or to be considered as an admission of the due performance of contract or any part thereof.
2. Five (5) percent of the gross R A Bill amount shall be retained from each bill as retention amount and the same will be paid with the final bill.

GC-83 **NOTICE FOR CLAIM FOR ADDITIONAL PAYMENT :**

If the Contractor considers that he is entitled to extra payment or compensation or any claim whatsoever in respect of work, he shall forthwith give notice in writing to the Engineer-In-Charge about his extra payment and / or compensation. Such notice shall be given to the

68
Engineer-In-Charge within ten (10) days from the happening of any event upon which Contractor basis such claims and such notice shall contain full particulars of the nature of such claim with full details and amount claimed. Failure on the part of the Contractor to put forward any claim with the necessary particulars as above, within the time above specified shall be an absolute waiver thereof. No omission by owner to reject any such claim and no delay in dealing therewith shall waiver by owner or any rights in respect thereof.

GC-84

PAYMENT OF CONTRACTOR'S BILL :

1. The price to be paid by the owner to Contractor for the work to be done and for the performance of all the obligations undertaken by the Contractor under contract shall be based on the contract price and payment to be made accordingly for the work actually executed and approved by the Engineer-In-Charge.
2. No payment shall be made for work costing less than Rs.2,00,000/- till the work is completed and a certificate of completion for Construction is given. But in case of work estimated to cost more than Rs.2,00,000/-, Contractor on submitting the bill thereof will be entitled to receive a monthly payment proportionate to the part thereof, approved and passed by Engineer-In-Charge, whose certificate of such approval and passing of the sum so payable shall be final and conclusive against contractor. This payment shall be made after necessary deductions as stipulated elsewhere in the contract documents for materials, security deposit etc. The payment shall be released to the Contractor within two (2) month of submission of the bill duly pre-occupied on proper revenue stamp. Payment due to Contractor shall be made by the owner by ECS/RTGS mode in Indian currency. Successful bidder must furnish his Bank details for RTGS/ECS with Account Branch of RMC.

GC-85

FINAL BILL :

The final bill shall be submitted by Contractor within one (1) month of the date of physical completion of work, otherwise the Engineer-In-Charge's certificate of the measurement and of total amount payable for work shall be final and binding on all parties.

GC-86

RECEIPT FOR PAYMENT :

Receipt for payment made on account of work when executed by a firm must be signed by a person holding Power of Attorney in this respect on behalf of Contractor except when described in the e-Tender as a limited company in which case the receipt must be signed in the name of the Company by one of its principal officers or by some person having authority to give effectual receipt for the Company.

GC-87

COMPLETION CERTIFICATE :

1. When the Contractor fulfills his obligation as per terms of contract, he shall be eligible to apply for Completion Certificate. Contractor may apply for separate Completion Certificate in respect of each such portion of work by submitting the completion documents along with such application for Completion Certificate.

The Engineer-In-Charge shall normally issue to Contractor the Completion Certificate within one (1) month after receiving an application thereof from Contractor after verifying, from the completion documents and satisfying himself that work has been completed in accordance with and as set out in the construction and erection drawings and the contract documents. Contractor after obtaining the Completion Certificate is eligible to present the final bill for work executed by him under the terms of contract.
2. Within one month of completion of work in all respects Contractor shall be furnished with a certificate by the Engineer-In-Charge of such completion but no certificate shall be given nor shall work be deemed to have been executed until all (i) scaffolding, surplus materials and rubbish is cleaned off site completely, (ii) until work shall have been measured by the

Engineer-In-Charge whose measurement shall be binding and conclusive and, (iii) until all the temporary works, labour and staff colonies etc. constructed are removed and the work site cleaned to the satisfaction of the Engineer-In-Charge. If Contractor shall fail to comply with the requirements as aforesaid or before date fixed for the completion of work, the Engineer-In-Charge may at the expense of Contractor remove such scaffolding, surplus materials and rubbish and dispose off the same as he thinks fit.

3. The following documents will form the completion documents: -
 - a) Technical documents according to which the work has been carried out.
 - b) Three sets of construction drawings showing therein the modifications and corrections made during the course of execution signed by the Engineer-In-Charge.
 - c) Completion Certificate for "Embedded" or "Covered" up work.
 - d) Certificate of final levels as set out for various works.
 - e) Certificate of test performed for various work.
 - f) Material appropriation statement for the materials issued by owner for work and list of surplus materials returned to owner's store duly supported by necessary documents. (N.A.)
4. Upon expiry of the period of defect liability and subject to Engineer-In-Charge being satisfied that work has been duly maintained by Contractor during the defect liability period of fixed originally or as extended subsequently and that Contractor has in all respects made up any subsidence and performed all his obligations under contract, the Engineer-In-Charge (without prejudice to the rights of owner in any way) give final certificate to that effect. The Contractor shall not be considered to have fulfilled the whole of his obligation until final certificate shall have been given by the Engineer-In-Charge.
5. Final Certificate only evidence of completion:
Except the final certificate, no other certificate of payment against a certificate or on general account shall be taken to be an admission by owner of the due performance of contract or any part thereof of occupancy or validity or any claim by the Contractor.

GC-88 TAXES, DUTIES, ETC. :

1. Contractor agrees to and does hereby accept full and exclusive liability for the payment of any and all taxes including Sales Tax, Duties, etc., now or hereinafter imposed, increased or modified from time to time in respect of work and materials and all contributions and taxes for unemployment, compensation, insurance and old age pension or annuities now or hereinafter imposed by the Central or State Government authorities with respect to or covered by the wages, salaries or other compensation paid to the persons employed by Contractor.
If the Contractor is not liable to Sales Tax assessment, a certificate to that effect from the Competent Authority shall be produced without which final payment to the Contractor shall not be made. No.P, 'C' and 'D' Form shall be supplied by the owner, and the Contractor shall be required to pay full tax as applicable.
2. Contractor shall be responsible for compliance with all obligations and restrictions imposed by the labour law or any other law affecting employer-employee relationship.
3. Contractor further agrees to comply and to secure the compliance of all sub contractors with applicable Central, State, Municipal and local laws and regulations and requirement. Contractor also agrees to defend,

indemnify the hold harmless the owner from any liability or penalty which may be imposed by Central, State or local authority by reasons of any violation by Contractor or sub Contractor of such laws, regulations or requirements and also from all claims, suits or proceedings that may be brought against owner arising under, growing out of or by reasons or work provided for by this Contract by third parties or by Central or State Government authority or any administrative Sub-Division thereof.

The Sales Tax on work contract will be borne by Contractor.

GC-89

INSURANCE :

Contractor shall at his own expenses carry and maintain the reputable Insurance Companies to the satisfaction of owner as follows :

1. Contractor agrees to and uses hereby accept full and exclusive liability for compliance with all obligations imposed by the Employer's State Insurance Act, 1948 and Contractor further agrees to defend, indemnify and hold owner harmless from any liability or penalty which may be imposed by the Central or State Government or local authority by reasons of any assorted violation by Contractor or Sub-Contractor or the Employees State Insurance Act, 1948 and also from all claims, suits or proceedings that may be brought against owner arising under, growing out of or by reasons of the work provided for by this contract whether brought by employees of Contractor by third parties or by Central or State Government authority or any administrative Sub-division thereof.

Contractor agrees to fill in with the Employees State Insurance Corporation, the declaration form and all forms which may be required in respect of Contractor's or sub-Contractor's employees whose aggregate remuneration is Rs.400/- p.m. or less and who are employed in work provided for or those covered by ESI from time to time under the agreement. The Contractor shall deduct and secure the agreement of the sub-Contractor to deduct the employees contribution as per the first schedule of the Employees State Insurance Act from wages. Contractor shall remit and secure the agreement of sub-contractor to remit to the State Bank of Indian Employees State Insurance Accounts, the employee's contribution as required by the Act. Contractor agrees to maintain all cards and records as required under the Act in respect of employees and payments and Contractor shall secure the agreements of the sub contractors to maintain in such records, any expenses incurred for the contributions, making contributions or maintaining records shall be to Contractors or sub-contractors own account. owner shall retain such sum as may be necessary from the contract value until Contractor shall furnish satisfactory proof that all contribution as required by the Employees State Insurance Act, 1948 have been paid.

2. Workman's compensation and employees liability insurance: Insurance shall be effected for all Contractors employees engaged in the performance of this contract. If any part of work is sublet, Contractor shall require the sub-Contractor to provide workman's compensation and employer's liability insurance, which may be required by owner.
3. Other Insurance required under law of regulations or by owner Contractor shall also carry and maintain any and all other insurance which may be required under any law or regulation from time to time. He shall also carry and maintain any other insurance, which may be required by owner.

GC-90

DAMAGE TO PROPERTY :

1. Contractor shall be responsible for making good to the satisfaction of owner any loss of and any damage to all structures and properties belonging to owner or being executed or procured or being procured by owner or of other agencies within the premises of all work of owner, if such loss or damage is due to fault and / or the negligence of willful act or omission of Contractor, his employees, agent, representatives or sub-Contractors.

2. Contractor shall indemnify and keep owner harmless of all claims for damage to properties other than property arising under by reasons of this agreement, such claims result from the fault and / or negligence or willful act or omission of Contractor, his employees, agents representative or sub-contractor.

GC-91 CONTRACTOR TO INDEMNIFY OWNER :

1. The Contractor shall indemnify and keep indemnified the owner and every member, officer and employee of owner from and against all actions, claims, demands and liabilities whatsoever under the in respect of the breach of any of the above clauses and / or against any claim, action or demand by any workman / employee of the Contractor or any sub-contractor under any laws, rules or regulations having force of laws, including but not limited to claims against the owner under the workman compensation Act, 1923, the Employee's Provident Funds Act, 1952 and / or the contract labour (Abolition and Regulations) Act, 1970.
2. PAYMENTS OF CLAIMS AND DAMAGES : If owner has to pay any money in respect of such claims or demands aforesaid, the amount so paid and the cost incurred by the owner shall be charged to and paid by Contractor without any dispute not withstanding the same may have been paid without the consent or authority of the Contractor.
3. In every case in which by virtue of any provision applicable in the workman's Compensation Act, 1923 or any other Act, owner be obliged to pay compensation to workmen employed by Contractor the amount of compensation so paid, and without prejudice to the rights of owner under Section-(12) Sub-section-(2) of the said Act, owner shall be at liberty to recover such amount from any surplus due to on to become due to the Contractor or from the security deposit. Owner will not be bound to contest any claim made under Section-(12) Sub-section-(2) of the said act except on written request of Contractor and giving full security for all costs consequent upon the contesting of such claim.

The Contractor shall protect adjoining sites against structural, decorative and other damages that could be caused to adjoining premises by the execution of these works and make good at his cost, any such damage, so caused.

GC-92 IMPLEMENTATION OF APPRENTICE ACT 1954 :

Contractor shall comply with the provisions of the apprentice Act 1954 and the orders issued there under from time to time. If he fails to do so, it will be a breach of contract.

GC-93 HEALTH AND SANITARY ARRANGEMENTS FOR WORKERS:

Contractor shall comply with all the rules and regulations of the local Sanitary Authorities or as framed by owner from time to time for the protection of health and provide sanitary arrangements of all labour directly or indirectly employed on the work of this contract.

GC-94 SAFETY CODE :

General :

Contractor shall adhere to safe construction practice and guard against hazardous and unsafe working conditions and shall comply with owner's rules as set forth herein.

First Aid and Industrial Injuries :

Contractor shall maintain First-Aid facilities for its employees and those of his sub-contractors.

Contractor shall make outside arrangements for ambulance service and for the treatment of industrial injuries. Name of those providing these services shall be furnished to Engineer-In-Charge prior to start of construction, and their telephone numbers shall be prominently posted in

All injuries shall be reported promptly to Engineer-In-Charge and a copy of Contractor's report covering each personal injury requiring the attention of a physician shall be furnished to owner.

General Rules :

Carrying and striking, matches, lighters inside the project area and smoking within the job site is strictly prohibited. Violators of smoking rules shall be discharged immediately. Within the operation area, no hot work shall be permitted, without valid gas, safety, fire permits. The Contractor shall also be held liable and responsible for all lapses of his sub-Contractors / employees in this regard.

Contractor's Barricades :

Contractor shall erect and maintain barricades without any extra cost, required in connection with his operation to guard or protect during the entire phase of the operation of this contract for -

- i) Excavation
- ii) Hoisting areas
- iii) Areas adjudged hazardous by Contractor's OR Owner's inspectors.
- iv) Owner's existing property liable to be damaged by Contractor's operations, in the opinion of Engineer-In-Charge / Site Engineer.

Contractor's employees and those of his sub-contractors shall become acquainted with owner's barricading practices and shall respect the provisions thereof.

Barricades and hazardous areas adjacent to but not located in normal routes of travel shall be marked by red lantern at night.

Scaffolding :

Suitable scaffolding shall be provided for workman for all works that cannot safely be done from ladders. When a ladder is used, an extra mazdoor shall be engaged for holding the ladder and if the ladder is used for carrying materials as well suitable footholds and handholds shall be provided on the ladder and the same shall be given an inclination not steeper than 1 in 4 (1 horizontal and 4 vertical).

Scaffolding or staging, more than 3.6 M. (12') above the ground or floor, swing or suspended from an overhead support or erected with stationary support shall have a guard rail properly attached, bolted, braced and otherwise fixed at least 1.0 M (3') high above the floor or platform or scaffolding or staging and extending along the entire length of the outside ends thereof with only such openings as may be necessary for the delivery of materials. Such scaffolding or staging shall be so fastened as to prevent it from swaying from the building or structure.

Working platforms, gangways, and stairways should be so constructed that they should not sag unduly or inadequately and if the height of the platform or the gangway of the stairway is more than 3.6 (12') above ground level or floor level, they should be closely boarded, should have adequate width and should be suitably fastened as described in 4.2 above.

Every opening in the floor of a building or in a working platform be provided with suitable means to prevent the fall of persons or materials by providing suitable fencing or railing whose minimum height shall be 1.0 M (3'.0").

Safe means of access shall be provided to all working platforms and other working places. Every ladder shall be securely fixed. No portable single ladder shall be over 9.0 M. (30') in length while the width between the side rails in rung ladder shall in no case be less than 30 cms (12 inches) for ladder up to and including 3.0 M. (10'), in longer ladders this width would be increased at least 6 mm (1/4") for each addition 30 c.m. (1.0) of length. Uniform step spacing shall not exceed 30 cms. (12"). Adequate precaution shall be taken to prevent danger from electrical equipment. No materials on any of the side of work shall be so

stacked or placed as to cause danger or inconvenience to any person or public. The Contractor shall also provide all necessary all necessary fencing and lights to protect the workers and staff from accidents, and shall be bound to bear the expenses of defence of every suit action or other proceedings at law that may be brought by any persons for injury sustained owing to neglect of the above precautions and to pay damages and costs which may be awarded in any such suit or action or proceedings to any such person, or which, may be with the consent of the Contractor be paid to compromise any claim by any such person.

Excavation :

All trenches 1.2 M (4') or more in depth, shall at all time be supplied with at least one ladder.

Ladder shall be extended bottom of the trench to at least 3" above the surface of the ground. The side of the trench which are 1.5 M (5') or more in depth shall be stopped back to give suitable slope, or securely held by timber bracing, so as to avoid the danger of sides to collapse. The excavated materials shall not be placed within 1.5 M (5') of the trench or half of the trench depth whichever is more. Cutting shall be done from top to bottom. Under no circumstances, undermining or under cutting be done.

Demolition :

Before any demolition work is commenced and also during the progress of the work all roads and open area adjacent to the work site shall either be closed or suitably protected.

No electric cable or apparatus which is liable to be a source of danger shall remain electricity charged.

All practical steps shall be taken to prevent danger to persons employed from risk of fire or explosion or flooding. No floor or other part of the building shall be so over loaded with debris or materials as to render it unsafe.

Safety Equipment :

All necessary personal safety equipment as considered necessary by the Engineer-In-Charge should be made available for the use of persons employed on the site and maintained in a condition suitable for immediate use, and the Contractor should take adequate steps to ensure proper use of equipment by those concerned.

Workers employed on mixing asphaltic materials, cement and lime mortars shall be provided with protective footwear and protective gloves.

Risky Place :

When the work is done near any place where there is a risk of drowning, all necessary safety equipment shall be provided and kept ready for use and all necessary steps taken for prompt rescue of any person in danger and adequate provision should be made for prompt first-aid treatment of all injuries likely to be sustained during the course of the work.

Hoisting Equipment :

Use of hoisting machines and tackles including their attachments, and storage and supports shall conform to the following standards or conditions.

These shall be of good mechanical construction, sound material and adequate strength and free from patent defect and shall be kept in good condition and in good working order.

Every rope used in hoisting or lowering materials or as a means of suspension shall be of durable quality and adequate strength and free from patent defects.

Every crane driver or hoisting appliance operator shall be properly qualified and no person under the age of 21 years should be in-charge of any hoisting machine including any scaffolding.

In case of every hoisting machine and of every chain ring hook, shackle, swivel and pulley block used in hoisting or lowering or as means of suspension,

the safe working load shall be ascertained by adequate means. Every hoisting machine and all gear referred to above shall be plainly marked with the safe working load and the conditions under which it is applicable shall be clearly indicated. No part of any machine or any gear referred to above in this paragraph shall be loaded beyond the safe working load except for the purpose of testing.

In case of departmental machine, the safe work load shall be notified by the Engineer-In-Charge, as regards Contractor's machine, the Contractor shall, notify, the safety working load of the machine to the Engineer-In-Charge. Whenever the Contractor brings any machinery to site of work he should get it verified by the Engineer-In-Charge concerned.

10.0 Electrical Equipment :

Motors, gears, transmission, electric wiring and other dangerous parts of hoisting appliances shall be provided with efficient safeguards, hoisting appliances should be provided with such means when will reduce to the minimum the risk of accidental descent of the load, adequate precautions shall be taken to reduce to the minimum the risk of any part or a suspended load becoming accidentally displaced. When workers are employed on electrical installations which are already energized, insulating mats, wearing apparel such as gloves, and booths as may be necessary shall be provided. The workers shall not wear any rings, watches and carry keys or other materials which are good conductors of electricity.

11.0 Maintenance of Safety Devices :

All scaffolds, ladders and other safety devices as mentioned or described herein shall be maintained in sound condition and no scaffold, ladder or equipment shall be altered or removed while it is in use. Adequate washing facilities should be provided at or near place of work.

12.0 Display of Safety Instructions :

The safety provisions should be brought to the notice of all concerned by display on a Notice Board at a prominent place at the work spot. The persons responsible for compliance of the safety code shall be named therein by the Contractor.

13.0 Enforcement of Safety Regulations :

To ensure effective enforcement of the rules and regulations relating to safety precautions, the arrangement made by the Contractor shall be open to inspection by the Welfare Officer, Engineer-In-Charge or Safety Engineer of the owner or their representatives.

No Exemption :

Notwithstanding the above clause 1.0 to 13.0 there is nothing to exempt the Contractor from the operations of any other Act or Rules in force in the Republic of India.

In addition to the above, the Contractor shall abide by the safety code provisions as per C.P.W.D. safety code framed from time to time.

GC-95 ACCIDENTS :

It shall be Contractor's responsibility to protect against accidents on the works. He shall indemnify the owner against any claim for damage or for injury to person or property resulting from, and in the course of work and also under the provisions of the workman's compensation Act. On the occurrence of an accident arising out of the works which results in death or which is so serious as to be likely to result in death, the Contractor shall within twenty-four hours of such accident, report in writing to the Engineer-In-Charge, the facts stating clearly and in sufficient details the circumstances of such accident and the subsequent action. All other accidents on the works involving injuries to person or damage to property other than that of the Contractor shall be promptly reported to the Engineer-In-Charge, stating clearly and in sufficient details the facts and circumstances of the accidents and the action taken. In all cases, the Contractor shall indemnify the owner against all loss or damage resulting directly or indirectly from the Contractor's failure to report in the manner aforesaid. This includes penalties or fines, if any, payable by the owner as a consequence of failure to give notice under the Workman's

Compensation Act, or failure to conform to the provisions of the said act⁷⁵ in regard to such accidents.

In the event of an accident in respect of which compensation may become payable under the Workman's Compensation Act VIII of 1923 including all modification thereof, the Engineer-In-Charge may retain out of money due and payable to the Contractor such sum of sums of money as may in the opinion of Engineer-In-Charge be sufficient to meet such liability. On receipt of award from the Labour Commissioner in regard to quantum of compensation, the difference in amount will be adjusted.

Addl/Asst. Engineer
R.M.C.

Dy.Ex.Engineer
R.M.C.

ADDL. CITY ENGINEER
R.M.C.

Signature of Contractor with Seal

PART-II

SECTION - 3

TECHNICAL SPECIFICATIONS

PART-II
SECTION – 3
TECHNICAL SPECIFICATIONS

CONTENT

SR NO	PARTICULARS
A	GENERAL
1	Scope of Contract
2	e-TENDER Price
3	Completion Schedule
4	General Technical Guideline
5	Classification of Strata
B	DETAILED TECHNICAL SPECIFICATION
B1	Material specification
1	Providing and testing of SWG pipe
2	Providing and supplying precast M.H. & H.C.C. frame and cover
B2	Labour specification
1	Excavation and Refilling
2	Providing and laying CC bedding for pipes
3	Providing sand/granular bedding for pipes
4	Lowering ,laying and jointing of SWG and RCC NP3 pipe
5	Removing surplus materials
6	Appurtenances
7	Breaking of Asphalt surface and re-instating of road
C	GENERAL MATERIAL SPECIFICATION
1	Concrete
2	Form Work
3	Reinforcement
4	Brick Masonry
5	Definition of Incomplete Work
6	Contractor to observe all conditions
D	ADDITIONAL CONDITIONS
E	SCHEDULE OF DRAWING

:: TECHNICAL SPECIFICATIONS ::

A. GENERAL

1. SCOPE OF CONTRACT :

The work entitled comprise of excavation of trenches with shoring and strutting wherever required bailing out water wherever necessary, laying of pipes, jointing including supply of material and material required for jointing, testing as per specifications, Construction of appurtenances such as brick Masonry Manholes, house chambers etc. as per the type design specified entirely of the specification of various works stipulated in the e- Tender. The work includes supply of sewer pipes i.e. stone ware pipes of ISI Marked and R.C.C. precast manhole frames & covers which shall have to be supplied at site or Municipal store by the contractor at specified and shown in schedule "B". Other material like cement etc shall have to supplied by the contractor from open market.

2. e- TENDER PRICE:

The rates quoted in the bill of quantities shall cover everything necessary for the due and complete execution of the work according to the drawings and other condition and stipulations of the contract including specifications of the evident, intend and meaning of all or either of them or according to customary usage and for periodical and final inspection and test and proof of the work in every respect and for measuring, numbering or weighing the same, including setting out and laying or fixing in position and the provision of all materials, power, tools, rammers, labour, tackle, platforms with impervious lapped joints for scaffolding, ranging roads, straight edged, cantering and boxing, wedges, moulds, templates, posts, straight rods, straight edged, cantering and boxing, wedges, moulds, templates, posts, straight rails, boning staves strutting, barriers, fencing lighting pumping apparatus, temporary arrangement for passage of traffic access to premises and continuance to drainage water supply and lighting (if interrupted by contractor's work) temporary sheds, painting, varnishing, polishing establishment for efficient supervision and stating arrangements for the efficient protective of life and property and all requisite plant and machinery of every kind.

The contractor shall keep every portion of the work clear of accumulation from time to time and shall leave every portion of the work clean, clear, perfect and at the conclusion of whole, providing at their own cost all such material implement, appliances and labour as the Engineer in charge may require to prove if it to be so.

3. COMPLETION SCHEDULE:

The contract period shall be as prescribed in tender document, from the date of notice to proceed. The Contractor shall submit his completion schedule and the program of works together with this e-Tender in conformity with completion schedule given in the documents.

4. GENERAL TECHNICAL GUIDELINE:

All the items occurring in the work and as found necessary during actual execution shall be carried out in the best workman like manner as per specifications and the written order of the Engineer in charge

Extra Claim in respect of extra work shall be allowed only if such work is ordered to be carried out in writing by the Engineer in charge

The contractor shall engage a qualified Engineer for the Execution of work who will remain present for all the time on site and will receive instructions and orders from the Engineer in charge or his authorized representative. The instruction and orders given to the contractor representative on site shall be considered as it given to the contractor himself.

The work order book as prescribed shall be maintained on the site of the work by the contractor and the contractor shall sign the orders given by the inspecting officers and shall carry out them properly.

Quantities specified in the e-Tender may vary at the time of actual execution and the contractor shall have no claim for compensation on account of such variation

Unexcavated lengths shall be left wherever required and so directed by the Engineer in charge during the currency of the contract and shall be tackled. If required, before completion of work.

Diversion of road, if necessary, shall be provided and maintained during the currency of the contract by the contractor at his cost.

Figured Dimensions of drawing shall supersede measurements by scale, special dimensions or directions in the specifications shall supersede all other dimensions.

All levels are given on drawings and the contractor shall be responsible to take regular level on the approved alignment before actually starting the work. The levels shall commence to the G.T.S. levels and shall be got approved from the Engineer in charge

If the arrangement of temporary drainage is required to be made during any work of this Contract, this shall be made by the Contractor without claiming any extra cost.

5. CLASSIFICATION OF STRATA:

All materials encountered in excavation will be classified in the following groups irrespective of mode of excavating the materials and the decision of the Engineer in charge in this regard shall be final and binding to the contractor.

Soils :

Soils of all sorts, silt, sand, gravel, soft murrum, stiff clay, kunkar and other soft excavation not covered in the items mentioned hereunder.

Hard Murrum :

Hard Materials comprising of all kinds of disintegrated rock or shale or indurate conglomerate interspersed with boulders, weathered and decomposed rock which could be removed with pick, bar, shove, wedges and hammers, though not without some difficulties.

Soft – Rock:

This shall include all materials which is rock but which does not need blasting and can be removed with a pick bar, wedges, pavement breakers, pneumatic tools etc.

Hard Rock:

This shall include rock occurring in mass or boulders which need blasting, this will also include rock to be removed by chiseling or any other method where blasting is not permissible.

6. The rates are inclusive of dewatering, if required.
7. Regarding water supply for hydro testing, necessary water, power, labour, etc. required for necessary test shall be arranged by the contractor at his own cost.
8. During construction activity, proper care must be taken for labour safety and must follow the provisions of the Labour laws.
9. TMT bars of Fe-415 should be confirming to IS:1786. The approved makes shall be TATA, SAIL, Vizag, Gallent, Electrotherm or other equivalent make as approved by engineer-in-charge.
10. Cement shall be ordinary Portland cement conforming to IS:269, IS:8112 or IS:12269 for all the works as per the instructions of engineer-in charge. The approved makes shall be Ambuja, Ultratech, LOTUS, Siddhi, Sanghi, Hathi or as per IS confirming. Minimum Cement content for the work should be as per attached circular No.RMC/C/Vigi.(Tech)/231 dt. 11/03/2022.
11. Testing of the materials like Brick, Sand, Aggregate, Reinforcement steel, etc. should have to be tested periodically as suggested by the Engineer-in-charge at Government approved material testing Laboratory and testing charges for the same has to be borne by the contractor.
12. In case of any ambiguity found in inspections / drawings etc, the decision of engineer-in-charge shall be final and binding to the contractor.

B. DETAILED TECHNICAL SPECIFICATIONS

B1 MATERIAL SPECIFICATION

1. Material:

Water:

Water shall not be salty or brackish and shall be clean, reasonably clear and free from objectionable quantities of silt and traces of oil and injurious alkalis, salts, organic matter and other deleterious material which will either weaken the mortar of concrete or cause efflorescence or attack the steel in RCC container for transport, storage and handling of water shall be clean. Water shall conform to the standards specified in I.S. 456 - Latest edition.

If required by the engineer-in-charge, it shall be tested by comparison with distilled water. Comparison shall be made by means of standard cement tests for soundness, change in time of setting and mortar strength as specified in I.S. 269 (Latest edition). Any indication of unsoundness, change in time of setting by 30 minutes or more or decrease of more than 10 per cent in strength of mortar prepared with water sample when compared with the results obtained with mortar prepared with distilled water shall be sufficient cause for rejection of water under test.

Water for curing mortar, concrete or masonry should not be too acidic or too alkaline. It shall be free of elements which significantly affect the hydration reaction or otherwise interfere with the hardening of mortar or concrete during curing or those which produce objectionable stains or other unsightly deposits on concrete or mortar surface.

Hard and bitter water shall not be used for curing.

Potable water will generally found suitable for curing mortar of concrete.

Lime:

Lime shall be hydraulic lime as per I S 712 - Latest Edition. Necessary tests shall be carried out as per I S 6932 9 (Parts I to X) Latest edition.

The following field tests for limes are to be carried out:

- i) A very rough idea can be formed about the type of lime by its visual examination i.e. fat lime bears pure white colour, lime in form of porous lumps of dirty white colour indicates quick lime and solid lumps are the un burnt lime stone.
- ii) Acid tests for determining the carbonate content in lime, lime Excessive amount of impurities and rough determination of lime.

Storage shall comply with I S 712 - Latest Edition. The slaked lime, it stored, shall be kept in a weather proof and damp-proof shed with impervious floor and sides to protect it against rain, moisture, and weather and extraneous materials mixing with it. All lime that has been damaged in any way shall be and all rejected materials shall be removed from site of work.

Field testing shall be done according to IS 269 (latest edition) to show the acceptability of materials.

Cement:

Cement shall be ordinary portland cement as per IS:269 or IS:8112 and IS:12669 (All Latest edition).

White Cement:

The white cement shall conform to I S 8042-E Latest edition.

Colored Cement:

Color cement shall be with white or grey portland cement as specified in the item of the work.

The pigments used for colored cement shall be of approved quality and shall not exceed 10% of cement used in the mix. The mixture of pigment and cement shall be properly ground to have a uniform color and shade. The pigments shall have such properties as to provide for durability under exposure to sunlight and weather.

The pigment shall have the property such that it is neither affected by the cement nor detrimental to it.

Sand:

Sand shall be natural sand, clean well graded, hard strong, durable and gritty particles free from injurious amounts of dust, clay, kankar nodules, soft or flaky particles Shale, alkali, salts organic matter, loam, mica or other deleterious substances and shall be got approved from the engineer-in-charge. The sand shall not contain more than 8 percent of silt as determined by field test. If necessary, the sand shall be washed to make it clean.

Coarse Sand:

The fitness modules of coarse sand shall not be less than 2.5 and shall not exceed 3.0. The sieve analysis of coarse shall be as under:

I.S. Sieve Designation	Percentage by weight passing sieve	IS Sieve percentage Designation	by weight percentage passing sieve.
4.75 mm	100	600 Micron	30-100
2.36 mm	90 to 100	300 Micron	5-70
1.18 mm	70-100	150 Micron	0-50

Fine Sand:

The fineness modules shall not exceed 1.0 The sieve analysis of fine sand shall be as under:

I.S. Sieve Designation	Percentage by weight passing sieve	IS Sieve percentage Designation	by weight Percentage Passing sieve.
4.75 mm	100	600 Micron	40-85
2.36 mm	100	300 Micron	5-50
1.18 mm	75-100	150 Micron	0-10

Stone Dust:

This shall be obtained from crushing hard black trap or equivalent. It shall not contain more than 8% of silt as determined by field test with measuring cylinder. The method of determining silt contents by fields test is given as under:

A sample of stone dust to be tested shall be placed without drying in 200 mm measuring cylinder. The quantity if the sample shall be such that it fills the cylinder upto 100 mm mark, the clean water shall be added upto 150 mm mark. The mixture shall be stirred vigorously and content allowed to settle for 3 hours.

The height of silt visible as settled layer above the stone dust shall be expressed as percentage of the height of the stone dust below. The stone containing more than 8% silt shall be washed so as to bring the content within the allowable limit.

The fitness nodules of stone dust shall not be less than 1.80

Stone Grit:

Grit shall consist of crushed or broken stone and be hard, strong dense durable clean of proper gradation and free from skin or coating likely to prevent proper adhesion of mortar. Grit shall generally be cubical in shape and as far as possible flaky elongated pieces shall be avoided. It shall generally comply with the provisions of IS 383 (Latest Edition). Unless special stone of particular quarries is mentioned, grit shall be obtained from the best black trap or equivalent hard stone as approved by the engineer-in-charge. The grit shall have no deleterious reaction with cement.

The grit shall conform to the following gradation as per sieve analysis:

I.S. Sieve Designation	Percentage passing through sieve	IS Sieve Designation	percentage passing through sieve
12.50 mm	100%	4.75 mm	0-20%
10.00 mm	85-100%	2.36 mm	0-25%

The crushing strength will be such as to allow the concrete in which it used to build up the specified strength of concrete.

The necessary tests for grit shall be carried out as per the requirements of I S 2386 (Part I to VIII) Latest edition as per instruction of engineer-in-charge. The necessity of test will be decided by the engineer-in-charge.

Cinder:

Cinder is well burnt furnace residue which has been fused or sintered into lumps of varying sizes.

Cinder aggregates shall be well burnt furnaces residue obtained from furnace using coal fuel only. It shall be sound clean and free from clay, dirt, ash or other deleterious matter.

The average grading for cinder aggregate shall be as mentioned below:

I.S. Sieve Designation	Percentage passing	IS Sieve Designation	percentage passing
20 mm	100%	4.75 mm	70
10 mm	86	2.36 mm	52

Lime Mortar:

Lime: Lime shall conform to specification M-2. Water: Water shall conform to specification M-1. Sand: Sand shall conform to specification M-6.

Proportion of Mix:

Mortar shall consist of such proportions of slaked lime and sand as may be specified in item. the slaked lime and sand shall be measured by volume.

Preparation of Mortar:

Lime mortar shall be prepared by process as per IS 1625 Latest edition. Power drive mill shall be used for preparation of lime mortar. The slaked lime shall be placed in the mill in an even layer and ground for 180 revolutions with a sufficient water. Water shall be added as required during grinding (care being taken not to add more water) that will bring the mixed material to a consistency of stiff paste. Thoroughly wetted sand shall then be added evenly and the mixture ground for another 180 revolutions.

Storage:

Mortar shall always be kept damp, protected from sun and rain till used up, covering it by tarpaulin or open sheds.

All mortar shall be used as soon as possible after grinding. It should be used on the day on which it prepared. But in no case, mortar made earlier than 36 hours shall be permitted for use.

Cement Mortar:

Water shall conform to specification M-1. Cement: Cement shall conform to specifications M-3. Sand: Sand shall conform to M-6.

Proportion of Mix:

Cement and sand shall be mixed to specified proportion, sand being measured by measuring boxes. The proportion of cement will be by volume on the basis of 50 kg/Bag of cement being equal to 0.342 Cu.M. The mortar may be hand mixed as directed.

Proportion of Mortar:

In hand mixed mortar, cement and sand in the specifications shall be thoroughly mixed dry on a clean impervious platform by turning over at least 3 times or more till a homogeneous mixture of uniform color is obtained. mixing platform shall be so arranged that no deleterious extraneous material shall get mixed with mortar or mortar shall flow out. While mixing, the water shall be gradually added and thoroughly mixed to form a still plastic mass of uniform color so that each particle of sand shall be completely covered with a film of wet cement. the water cement ratio shall be adopted as directed.

The mortar so prepared shall be used within 30 minutes of adding water. Only such quantity of mortar shall be prepared as can be used within 30 minutes.

Stone Coarse Aggregate for Nominal Mix Concrete.

Coarse aggregate shall be of machine crushed stone of black trap or equivalent and be hard, strong, dense, durable, clean and free from skin and coating likely to prevent proper adhesion of mortar.

The aggregate shall generally be cubical in shape. Unless special stones of particular quarries are mentioned, aggregates shall be machine crushed from the best black trap or equivalent hard stone as approved. Aggregate shall have no deleterious reaction with cement. The size of the coarse aggregate for plain cement concrete and ordinary reinforced cement concrete shall generally be as per the table given below, however, in case of reinforced cement concrete the maximum limit may be restricted to 6 mm, less than the minimum lateral clear distance between bars of 6 mm less than the cover whichever is smaller.

I S Sieve designation	Percentage passing for single sized aggregates of nominal size			I S Sieve designation	Percentage passing for single sized aggregates of nominal size		
	40 mm	20 mm	16 mm		40 mm	20 mm	16 mm
80 mm	--	--	--	12.5 mm	--	--	--
63 mm	100	--	--	10 mm	0.5	--	0.30
40 mm	85-100	100	--	4.75 mm	--	0.20	0.5
20 mm	0-20	85-100	100	2.35 mm	--	0.50	--
16 mm			8-100	--	--	--	--

Note:

This percentage may be the engineer-in-charge when considered necessary for obtaining better density and strength of concrete.

The grading test shall be taken in the beginning and at the change of source of materials. The necessary tests indicated in IS 383 Latest edition and IS 456 Latest edition shall have to be carried out to ensure the acceptability. The aggregates shall be stored separately and handled in such a manner as to prevent the intermixing of different aggregates. If the aggregates are covered with dust, they shall be washed with water to make them clean.

Black Trap or Equivalent Hard Stone Coarse:

Aggregate for Design Mix concrete:

Coarse aggregate shall be of machine crushed stone of black trap or equivalent hard stone and be hard, strong, dense, durable, clean and free from skin and coating likely to prevent proper adhesion of mortar.

The aggregates shall generally be cubical in shape. Unless special stones of particular quarries are mentioned, aggregates shall be machine crushed from the best, black trap or equivalent hard stones as approved. Aggregate shall have no deleterious reaction with cement.

The necessary tests indicated in IS 383 Latest edition and IS 456 Latest edition shall have to be carried out to ensure the acceptability of the material.

If aggregate is covered with dust, it shall be washed with water to make it clean.

Brick Bats Aggregate:

Brick bat aggregate shall be broken from well burnt or slightly over burnt and dense bricks. It shall be homogeneous in texture, roughly cubical in shape, clean and free from dirt of any other foreign material. The brick bats shall be of 40 mm to 50 mm size unless otherwise specified in the item. The under burnt or over burnt brick bats shall not be allowed.

The brick bats shall be measured by suitable boxes as directed.

Bricks:

The bricks shall be hard or machine moulded and made from suitable soils and burnt. They shall be free from cracks and flaws and nodules of free lime. They shall have smooth rectangular faces with sharp corners and shall be of uniform colors.

The bricks shall be moulded with a frog of 100 mm x 40 mm and 10 mm to 20 mm deep on one of its flat sides. The bricks shall not break when thrown on the ground from a height of 600 mm.

The size of modular bricks shall be 190 mm x 90 mm.

The size of the conventional bricks shall be as under:
(9" x 4.3/8" x 2.3/4") 225 x 110 x 75 mm

Only bricks of one standard size shall be used in one work. The following tolerances shall be permitted in the conventional size adopted in a particular work.

Length $\pm 1/8"$ (3mm) width : $\pm 1/16"$ (1.5mm)
Height: $\pm 1/16"$ (1.5 mm)

The crushing strength of the brick shall not be less than 35 kg/sq.cm. The average water absorption shall not be more than 20 percent by weight. Necessary tests for crushing strength and water absorption etc., shall be carried out as per IS: 3495 (Part I to IV) - latest edition.

Stone:

The stone shall be of the specified variety such as granite / trap stone / quartzite or any other type of good hard stones. The stones shall be obtained only from the approved quarry and shall be hard, sound, durable and free from defects like cavities cracks, sand holes flaws, injurious veins, patches of loose or soft materials etc. and weathered portion and other structural defects or imperfection tending to affect their soundness and strength. The stone with round surface shall not be used. The percentage of water absorption shall not be more than 5% dry or wet. When tested in accordance with I.S.1124 - Latest edition. The minimum crushing strength of the stone be 200 kg/sq.cm unless otherwise specified.

The samples of the stone to be used shall be got approved before the work is started.

The khanki facing stone shall be dressed by chisel as specified in the item for khanki facing in required shape and size. The face of the stone shall be

so dressed that the bushing on the exposed face shall not project by more than 40 mm from the general wall surface and on face to be plastered it shall not project by more than 19 mm nor shall it have depressions more than 10 mm from the average wall surface.

Laterite Stone

Laterite stone shall be obtained from the approved quarry. It shall be compacted, in texture, sound, durable and free from soft patches. Its shall have minimum crushing strength of 10 Kg/sq.cm in its dry condition. It shall not absorb water more than 20 % of its own weight, when immersed for 24 hours in water After quarrying, the stone shall be allowed to weather for some time before using in work. '

The stone shall be dressed into regular rectangular blocks so that all faces are free from waviness and unevenness, and the edges true and square.

Those types of stone in which white clay occurs should not be used. Special corner stones shall be provided where so directed.

Mild Steel Bars:

Mild steel bars reinforcement for RCC work shall conform to IS 432 (Part-II) Latest edition and shall be of tested quality. It shall also comply with relevant part of IS 456 Latest edition.

All the reinforcement shall be clean and free from dirt, paint, grease, mill scale or loose or thick rust at the time of placing.

For the purpose of payment, the bar shall be measured correct upto 10 mm length and weight payable worked out at the rate specified below:

1	6 mm	0.22 Kg/Rmt	8	20 mm	2.47 Kg/Rmt
2	8 mm	0.39 Kg/Rmt	9	22 mm	2.98 Kg/Rmt
3	10 mm	0.62 Kg/Rmt	10	25 mm	3.85 Kg/Rmt
4	12 mm	0.89 Kg/Rmt	11	28 mm	4.83 Kg/Rmt
5	14 mm	1.21 Kg/Rmt	12	32 mm	6.31 Kg/Rmt
6	16 mm	1.58 Kg/Rmt	13	36 mm	7.99 Kg/Rmt
7	18 mm	2.00 Kg/Rmt	14	40 mm	9.86 Kg/Rmt

High Yield Strength Steel Deformed Bars:

High yield strength steel deformed bars shall be either cold twisted other rolled and shall conform to IS 1786 Latest edition and IS 1139 Latest edition respectively.

Other provisions and requirements shall conform to specification No.M-18 for Mild Steel Bars.

High Tensile Steel Wires:

The high tensile wires for use in pre stressed concrete work shall conform to IS 2090 Latest edition.

The tensile strength of the high tensile steel bars shall be as specified in the item. In absence of the given strength the minimum strength shall be taken as per part 6-1 of the IS 1785 Latest edition. Testing shall be done as per I S requirements.

The high tensile shall be free from loose mill scale, rust, oil grease, or any other harmful matter. Cleaning of steel bars may be carried out immersion in solvent solution, wire brushing or passing through a pressure box containing carborundum.

The high tensile wire shall be obtained from manufacturer in coil having diameter not less than 350 times the diameter of wire itself, so that wire springs back straight on being uncoiled.

M-20(A) Plain Carbon Drawn Steel Wires:

The plain carbon drawn steel wires for use in precast concrete work shall be conform to IS 1785 (Part-II) Latest edition.

The tensile strength of the P C steel bars shall be as specified in the item. In absence of the given strength, the minimum strength shall be taken as per IS: 1785 Latest edition. Testing shall be done as per IS requirements.

The P C steel bars shall be free from loose mill scale, rust, oil grease, or any other harmful matter. Cleaning of steel bars may be carried out immersion in solvent solution, wire brushing or passing through a pressure box containing carborandum.

Mild Steel Binding Wire:

The mild steel wire shall be of 1.63 mm, 22 mm (16 or 18 gauge) diameter and shall conform to I S 280 Latest edition.

The use of black wire will be permitted to binding reinforcement bars. It shall be free rust, oil paint, grease, loose mill scale or any other undesirable coating which may prevent adhesion of cement mortar.

Structural Steel:

All structural steel shall confirm to IS 226 Latest edition. The steel shall be free from the defects mentioned in IS 226 Latest edition and shall have a smooth finish. the material shall be free from loose mill scale, rust pits or other defects affecting the strength and durability. River bars shall conform to IS 1148 Latest edition.

When the steel is supplied by the contractor, test certificate of the manufacturer shall be obtained according to IS 226 Latest edition and other relevant Indian Standards.

Galvanized Iron Sheets :

The galvanized iron sheets shall be plain or corrugated sheets of guages as specified in item. The G.I. Sheets shall conform to I.S. latest edition. The sheets shall be undamaged in carriage and handling either by rubbing off of zinc coating or otherwise. They shall have clean and bright surface and shall be free from bends, holes, rust or white powdery deposit.

The length and width G.I. sheet shall be as directed as per site condition.

M-23-A : G.I. Valleys gutter, ridges :

The G.I. ridges and hips shall be of plain galvanized sheets Class-3 of the thickness as specified in item. These shall be 600 mm in and width and properly bent up to shape without damage to the sheets an in process of bending.

Valleys gutters and flashings shall also be of galvanized sheets of thickness as specified in item. Valleys shall be 900 mm. wide overall and flashing shall be 380 mm. wide overall. They shall be bent to the required shape without damage to the sheet in the process of bending.

M-24. Asbestos Cement Sheets :

Asbestos cement sheets plain, corrugated or semi-corrugated shall conform to I.S. latest edition. The thickness of the sheets shall be as specified in the item. The sheets shall be free from all defects such as cracks, holes, deformities, edges or otherwise damaged.

Ridge & Hips :

Ridge and hips shall be of same thickness as that of A.C. sheets. The types of ridges shall be suitable for the type of sheets and location. Other accessories to be used in roof such as flashing pieces eaves filler pieces, valley gutters, north light and ventilator curves, barge boards etc. shall be of standard manufacture and shall be suitable for the type of sheets and location.

M-25. Mangalore Pattern Roof Tiles :

The mangalore pattern tiles shall conform to I.S. latest edition for Class AA or class A type as specified in item. Sample of the tiles to be provided shall be got approved from the Engineer-in-charge. Necessary tests shall be carried out as directed.

M-26 Shuttering:

The shuttering shall be either of wooden planking of 30 mm minimum thickness with or without sheet lining or of steel plates stiffened by steel angles. The shuttering shall be supported on battens and beams and props of vertical bullies properly cross braced together so as to make the centering rigid. In places of bullies props, brick pillar of adequate section built in mud mortar may be used.

The form work shall be sufficiently strong and shall have camber, so that it assumes correct shape after deposition of the concrete and shall be able to resist forces caused by vibration of live load of men working over it and other incidental load associated with it. The shuttering shall have smooth and even surface. Its joints shall not permit leakage of cement grout.

If at any stage of work during or after placing concrete in the structure, the form work sags or bulges out beyond the required shape of the structure, the concrete and adequately rigid form work. The complete form work shall be got inspected by and got approved from the engineer-in-charge before the reinforcement bars are placed in position.

The props shall consist of bullies having 100 mm minimum dia. measurement at mid length and 80 mm at thin end and shall be placed as per design requirement. These shall rest squarely on wooden sole plates 40 mm thick and minimum bearing area of 0-10 sq.m laid on sufficiently hard base.

Double wedges shall further be provided between the sole plate and the wooden props so as to facilitate tightening and easing of shuttering without jerking the concrete.

The timber used in shuttering shall not be so dry as to absorb water from concrete and swell or bulge nor so green or wet as to shrink after erection. The timber shall be properly sawn and planned on the sides and the surface coming in contact with concrete. Wooden form work with metal sheet lining or side plates stiffened by steel angles shall be permitted.

As far as practicable, clamps shall be used to hold the forms together and use of nails and spikes avoided.

The surface of timber shuttering that would come in contact with concrete shall be well wetted and coated with soap solution before the concreting is done. Alternatively, coat of raw linseed oil or oil of approved manufacturer may be applied in place of soap solution. In case of steel shuttering either soap solution or raw linseed oil shall be applied after thoroughly cleaning the surface. Under no circumstances, black or brunt oil shall be permitted.

The shuttering for beams and slabs shall have camber of 4 mm per meter (1 in 250) or as directed by the engineer-in-charge, so as to offset the subsequent deflection for cantilevers, the camber of free end shall be 1/50 of the projected or as directed by the engineer-in-charge.

M-27. Expansion joints – Pre moulded filler:

The item provides for expansion joints in R.C.C. frame structures for internal joints, as well as exposed joints, with the use of pre moulded bituminous joint filler.

Pre moulded bituminous joint filler, i.e. performed strip of expansion joint filler shall not get deformed or broken by twisting, bending or other handling when exposed to atmospheric condition. Pieces of joint filler that have been damaged shall be rejected.

Thickness of the pre-moulded joint filler shall be 25 mm. unless otherwise specified.

Pre moulded bituminous joint filler shall conform to I.S. Latest edition.

M-28. Expansion joints Copper strips & hold fasts :

The item provide for expansion joints in R.C.C. frame structure for internal joint as well as for exposed joints with the use of necessary copper strip and holdfasts.

Copper sheet shall be of 1.25 mm thick and of 1.25 mm width and the "U" shape in the middle.

Copper strip shall have holdfast of 3 mm diameter copper rod fixed to the plate soldered on strip at intervals of about 30 cm or as shown in the drawing or as directed. The width of each flange (horizontal side) of the copper plate to be emvidded in the concrete work shall be 25 mm. depth of "U" to be provided in the expansion joint, in the copper plate shall be of 25 mm.

M-29. Teak wood :

The teak wood shall be of good quality as required for the item to be executed. When the kind of wood is not specifically mentioned, good Indian teak wood as approved shall be used.

Teak wood shall generally be free from large, loose, dead or cluster knots flaws, shakes, warps, twists, bends; or any other defects. It shall generally be uniform in substance and of straight fibres as far as possible. It shall be free from rot, decay, harmful fungi and other defects of harmful nature, which will affect the strength, durability or its usefulness for the purpose for which it is required. The colour shall be uniform as far as possible . Any effort like paining, using any adhesive resinous materials

made to hide the defects shall render the pieces liable to rejection by the Engineer-in-Charge.

All scantlings, planks etc. shall be sawn in straight lines and planes in the direction of grains and of uniform thickness.

The tolerances in the dimensions shall be allowed at the rate of 1.5 mm, per face to be planed.

First class teak wood :

First class teak wood shall have no individual hard and sound knots, more than 6 sq.cm. in size and the aggregate area of such knots shall not be than 1 % of area of piece, the timber shall be closed grained.

Second Class Teak Wood :

No individual hard and sound knots shall be more than 15 sq.cm. in size and aggregates area of such - knots shall not exceed 2 % of the area of piece.

M-29. A Non-teak wood :

The non-teak wood shall be chemically treated, seasoned as per I.S. Specification and of good quality. The type of, wood shall be got approved before collecting the same on site. Fabrication of wooden members shall be started only after approval.

For this purpose wood of Bio, Kalai, Sires, Saded, Behda, Jamun, Sisoo will be used for door where as only Kalai, Halda, Sires, Kalam etc. will be permitted for shutters after proper seasoning and chemical treatment, The non-teak wood shall be free from large, loose dead or cluster knots, flows, shakes, warps, bends or any other defects. It shall be uniform in substance and of straight fibres as far as possible. It shall be free from rots, decay, harmful fungi and other defects of nature which will effect the straight durability or its usefulness for the purpose for which it is required. The colour of wood shall be uniform as far as possible. The scantlings planks etc. shall be sawn in straight lines and planes in the direction of grain and of uniform thickness. The department will use the Agency to produce certificate from Forest Department in event of Dispute and the decision of the Department shall be final and binding to the contractor: The tolerance in the dimension shall be allowed at 1.5 mm. per face to be planed.

M-30. Wooden flush door shutters (solid core) :

The solid core type flush door shutters shall be of decorative or non-decorative type as specified in the drawing. The size and thickness of the shutter shall be as specified in drawings or as directed. The timber species for core shall be used as per I.S. Latest edition. The timber shall be free from decay and insect attack. Knots and knot holes less than half the width of cross-section of the members in which they occur may be permitted. Pitch pockets, pitch streaks and harmless pin holes shall be permissible except in the exposed edges of the core members. The commercial plywood, cross-bands shall conform to I.S: latest edition.

The face panel of the shutters shall be formed by gluing by the hot press process on both faces of the core with either, plywood or cross-bands and face veneers. The lipping, rebating, opening of glazing; venetian etc. shall be provided if specified in the drawing.

All edges of the door shutters shall be square. The shutters shall be free from twist or warp in its plane. Both faces of the shutters shall be sandpapered to smooth even texture.

The shutters shall be tested for

- (1) End immersion test : The test shall be carried out as per I.S. latest edition. There shall be no delamination at the end of the test.
- (2) Knife test : The face panel when tested in accordance with I.S. latest edition shall pass the test.
- (3) Glue adhesion test : The flush door shall be tested for glue adhesive test in accordance with I.S.: latest edition. The shutters shall be considered to have passed the test if no delamination occurs in the glue lines in the plywood and if no single delamination more than 80 mm in length and more than 3 mm in depth has occurred in the assembly glue lines between the plywood face and the stile and rail. Delamination at the corner shall be measured continuously around the corner. Delamination at the knots, knot holes and other permissible wood defects shall not be considered in assessing the sample.

The tolerance in size of solid core type flush door shall be as under:
In Nominal thickness ± 1.2 mm in Nominal height ± 3 mm.

The thickness of the shutter shall be uniform throughout with a permissible variation of not more than 0.8 mm: when measured at any two points.

M-31. Aluminum doors, windows, ventilators :

Aluminum alloy used in the manufacture of extruded window sections shall conform to I.S. designation HEA-WP of I.S. : latest edition and also to I.S. Designation WVG-.WP of I.S. latest edition. The section shall be as specified in the drawing and design. The fabrication shall be done as directed.

The hinges shall be cast or extruded aluminum hinges of same type as in window but of larger size.

The hinges shall normally be of 50 mm. projecting type. Non-projecting type of hinges may also be used if directed. The handles of door shall be of specified design. A suitable lock for the door operable from outside or inside shall be provided. In double, shutter door, the first closing shutter shall have concealed aluminum alloy bolt at top and bottom,

M-32. Rolling Shutters.

The rolling shutters shall conform to I.S. latest edition. Rolling shutters shall be supplied of specified type with accessories. The size of the rolling shutters shall be specified in the drawings. The shutters shall be constructed with interlocking lath sections formed from cold rolled steel strips not less than 0.9 mm. thick and 80 mm. wide for shutters up to 3.5 mm, width not less than 1.25 mm, thick and 80 mm. wide for shutter 3.5 mm in width and above unless otherwise specified,

Hood covers shall be of mild steel deep channel section and of rolled pressed or build up (fabricated) joint less construction. The thickness of sheet used shall not be less than 3.5 mm.

Hood covers shall be made of M S Sheets not less than 0.90 mm. thick. For shutters having width 3.5 Meter and above, the thickness of M.S. sheet for the hood cover shall be not less than 1.25 mm.

The spring shall be of best quality and shall be manufactured from tested high tensile spring steel wire or strip of adequate strength to balance the shutters in all position. The spiting pipe shaft etc, shall be supported on strong M.S. or malleable C.I. brackets. The brackets shall be fixed on or under the lintel as specified with rawl plugs and screws bolts etc.

The rolling shutters shall be of self rolling up to 8 Sq. m. clear area without ball bearing and up to 12 Sq. rn. clear area with ball bearing. If the rolling shutters are of larger, than gear operated type shutters shall be used The locking arrangement shall be provided at the bottom of shutter at both ends. The shutters shall be opened from outside, The shutters completed with door suspension shafts, looking arrangements, pulling hooks handles and other accessories.

M-33. Collapsible Steel Gate :

The collapsible steel gate shall be in one or two leaves and size as per approved drawings or as specified. The gate shall be fabricated from best quality mild steel channels, flates etc. Either steel pulleys or ball - bearings shall be provided in every doubly channel, Unless otherwise specified the particulars of collapsible gate shall be as under :

- (a) Pickets : These shall be of 20 mm. M.S. channels of heavy sections unless otherwise shows on drawings. The distance center to center of pickets shall be 12 cms with an opening of 10 Cms.
- (b) Pivoted M.& flats shall be 20 mm x 6 mm.
- (c) Top and bottom guides shall be from tee or flat iron of approved size.
- (d) The fittings like stoppers, fixing hold fasts, locking cleats brass handles and cast iron rollers shall be of approved design and size.

M-34. Welded Steel Wire Fabric

Welded steel wire fabric for general purpose shall be manufactured from cold drawn steel wire "as drawn" or galvanized steel conforming to LS. Latest edition with longitudinal and transverse wire securely connected at every intersection by a process of electrical resistance welding and conforming to I.S. latest edition. It shall be fabricated and finished in workmanlike manner and shall be free from injurious defects and shall be rust proof. The type of mesh shall be oblong or square as directed. The mesh sizes and size of wire for square as well as oblong welded steel wire fabric shall be as directed. The steel wire fabric in panels shall be in one whole piece in each panel as far as stock sizes permit.

M-35. Expanded Metal Sheets :

The expanded metal sheets shall be free from flaws, joints, broken strands, laminations and other harmful surface defects. Expanded metal steel sheet shall conform to I.S. latest edition, except that blank sheets need not be with guaranteed mechanical properties. The size of the diamond mesh of expanded metal and dimensions of strands (width and thickness) shall be as specified. The tolerance on nominal weight of expanded metal sheets shall be of 10 percent.

Expanded metal in panels shall be in one whole piece in each panel as far as stocks sizes permit. The expanded metal sheets shall be coated with suitable protective coating to prevent corrosion,

M-36. Mild Steel Wire (Wire Gauze Jali) :

Mild steel wire may be galvanized, as indicated. All finished steel wire shall be well cleanly drawn to the dimensions, and size of wire as specified in item. The wire shall be sound, free from splits, surface flaws, rough jagged-and imperfect edges and other harmful surface defect and shall conform to I.S. latest edition.

M-37. Plywood

The plywood for general purpose shall conform I.S. latest edition.

Plywood is made by cementing together thin boards or sheets of wood into panels. There are always an odd number of layers, 3, 5, 7, 9 ply etc. The plies are placed so that grain of each layer is at right angle to the grain in the adjacent layer.

The chief advantages of plywood over a single board of the same thickness is the more uniform strength of the plywood, along the length and width of the plywood and greater resistance, to cracking and splitting with change in moisture content.

Usually synthetic resins are used for gluing, phenolic resins are usually cured in a hot press which compresses and simultaneously heats the plies between hot plates which maintain a temperature of 90 degree C to 140 degree and a pressure of 11 to 14 Kg/Sq. Cm. on the wood. The time of heating may be anything from 2 to 60 minutes depending upon thickness.

When water glue are used the wood absorbs so much water that the finished plywood must be dried carefully. When synthetic resins are used as adhesive the finished plywood must be exposed to an atmosphere of controlled humidity until the proper amount of moisture has been absorbed.

According to I.S. Latest edition, the plywood for general purpose shall be of the grades namely BWR; WWR and CWR, depending upon the adhesives used for bonding the veneers, and it will be further classified into six type namely AA, AB, AC, BB, BC and CC, based on the quality of the two faces, each face being moisture content not less than 8 percent and not more than 16 percent.

37.8. Thickness of plywood boards

Board	Thickness	Board	Thickness	Board	Thickness	Board	Thickness
3 ply	3 mm	3 ply	5 mm	3 ply	9 mm	3 ply	16 mm
	4 mm		6 mm		13 mm		19 mm
	5 mm		8 mm		16 mm		19 mm
	6 mm		9 mm		13 mm		25 mm

Glass :

All glass shall be of the best quality, free from specks, bubbles, smokes, veins, air, holes blisters, and other defects. The kind of glass to be used shall be as mentioned in the item or specification or in the special provisions or as shown in detailed drawings. Thickness of glass panes shall be uniform. The specifications for different kinds shall be as under:

Sheet Glass:

In absence of any specified thickness or weight in the item or detailed specifications of the item of work, sheet glass shall be weighing 7.5 Kg/Sq. m. for panes upto 600 mmx500 mm.

For panes larger than 600 mm.x600 mm. and upto 800 mm.x800 mm. the glass weighing not less than 8.75 Kg Sq. m. shall be used. For bigger panes upto 900 mm:x900 mm. glass weighing not less than 8.75 Kg/Sq. m. shall be used. For bigger panes upto 900 mm.x900 mm. glass weighing not less than 11.25 Kg/Sq. M. shall be used

Sheet glass shall be patent flattened glass of best quality and of glazing and framing purposes shall conform to I.S. latest edition. Sheet glass of the specked colour used, if so shown on detailed drawings or so specified. For important buildings and for panes with any dimension over 900 mm. plate glass of specified thickness shall be used.

Plate Glass :-

When plate glass is specked, it shall be "Polished patent plate glass" of best quality. It shall have both the surface ground late and parallel and polished to obtain clear undisturbed vision and reflection. The plate glass shall be of the thickness mentioned in the item or as shown in the detailed drawing or as specified. In absence of any specified thickness, the, thickness of plate glass to be supplied shall be 6 mm. and a tolerance of 0.20 mm. shall be admissible.

Obscured Glass:

This type of glass transmits light so that vision is partially or almost completely obscured. Glass shall be plain rolled, figured, ribbed or fluted, or frosted glass as may be specked as required. The thickness and type of glass shall be as per details on drawings or as specified or as directed.

Wired Glass :

Glass shall be with wire netting embedded in a sheet of plate glass. Electrically welded 13 mm. Georgian square mesh shall be used.

Thickness of glass shall not be less than 6 mm. Wired glass shall be of type and thickness as specified.

Acrylic Sheets :

Acrylic sheet shall be of thickness as specified in the item and of an specked shape size as the case maybe. Panels may be flat or curved. It should be light in weight. It shall be colourless or coloured or opaque as specified in the item. Colourless sheet shall be as transparent as the finest optical glass. Its light transmission rate shall be about 95%. Transparency shall not be affected for the sheets thickness of it shall be extremely resistant to sunlight, weather and temperatures.

It shall not show any significant yellowing or change in physical properties or loss of light transmission over a longer period of use. The sheet shall be impact resistant also. Sheets should be of such quality that they can be cut, bent and jointed, as desired. Solution or the joints shall be used as per the requirement of manufacturer.

M-40. Particle board :

The particle boards used for face panels shall of best quality free from any defects. The particle boards shall be made with phenolamaldehyde adhesive. The particle boards shall conform to IS latest edition "Specification for wood particle board for general purpose" The size and the thickness shall be as indicated.

M-41. Expanded polystyrene or tamed styroper slabs

The expanded polystyrene ceiling boards and tiles shall be of approved make and shall be of size, thickness finish and colour as indicated. It shall be of high density and suitable for use as insulation material. The insulating material shall be like slab of Thermo Cole etc.

M-42. Resign bonded fiber glass :

The resign bonded fiber glass tiles or rolls shall be of approved make and shall be followed.

For test of Mineral wool thermal insulation Blanker IS. : latest edition shall be of sizes, thickness and finish as indicated.

Insulation wood blanket shall be with the following coverings on one or both side as indicated.

- (1) Bituminised hessian Kraft paper for use in position where moisture has to be excluded.
- (2) Hessian cloth or Kraft paper, for keeping out dust
- (3) G. I. wire netting, suitable for surfaces to be plastered over.

M- 43. Fixtures and fasteningsGeneral

The fixtures and fastenings, that is butt, hinges, tee and strap hinges sliding door bolts tower bolts, door latch, bath-room latch, handless door stoppers, casement window fasteners, casement stay sand ventilators catch shall be made of the metal as specked in the item or its specification.

They shall be of iron, brass, aluminum, chromium plated iron, chromium plated brass, copper oxidized iron, copper oxidized brass or anodized aluminum as specified.

The fixtures shall be heavy, medium or light type. The fixtures and fastenings shall be smooth finished and shall be such as will ensure ease of operations.

The sample of fixture and fastenings shall be got approved as regards, quality and shape before providing them in position.

Brass and anodized aluminum fixtures and fastening shall be bright finished.

Holdfasts :

Holdfasts shall be made from mild steel flat 30 cm. length and one of the holdfasts shall be bent at right angle and two nos. of 6 mm- diameter holes, shall be made in it for fixing it to the frame with screws. At the other end, the holdfast shall be forked and bent at right angles in opposite directions

Butt hinges:

Railway standard heavy type butt hinges shall be used when so specified. Tee and strap hinges shall be manufactured from M.S. Sheet

Siding door-bolts (Aldrops):

The aldrops as specified in the item shall be used and shall be got approved.

Tower bolts (Barrel Type):

Tower bolts as specified in the item shall be used and shall be got approved.

Door Latch

The size of door latch shall be taken as the length of latch.

Bathroom Latch

Bathroom latch shall be similar to tower bolt.

Handle

The size of the handles shall be determined by the inside grip length of the handles. Handles shall have a base plate of length 50 mm. more than the size of the handle.

Door Stoppers

Door Stoppers shall be either floor door stopper type or door catch type. Floor stopper shall be of overall size as specified and shall have a rubber cushion.

Door Catch

Door catch shall be fixed at a height of about 900 mm. from the floor level such that one part of the catch is fitted on the inside of the shutter and the other part is fixed in the wall with necessary wooden plug arrangements for appropriate fixity. The catch shall be fixed 20 mm. inside the face of the door for easy operation of catch.

Wooden Door Stop with hinges

Wooden door stop of size 100 mm X 60 mm.X 40 mm. shall be fixed on the door frame with a hinge of 75 mm. size and at a height of 900 mm. from the floor level. The wooden door stop shall be provided with 3 coats of approved oil paint.

Casement window Fastener

Casement window fastener for single leaf window shutter shall be left or right handed as directed.

Casement stays (Straight Peg Stay) :

The stays shall be made from a channel section having three holes at appropriate position so that the window can be opened either fully or partially as directed. Size of the stay shall be 250 mm to 300mm as directed.

Ventilator Catch

The pattern and, shape of the catch shall be as approved.

Pivot

The base and socket plate shall be made from minimum 3 mm. thick plate, and projected pivot shall not be less than 12 mm. diameter and 12 mm. length and shall be firmly riveted to the base plate in case of iron and in single piece in the case of brass pivot.

M-44. Paints :

Oil paints shall be of the specified colour and shade, and as approved. The ready mixed paints shall only be used. However, if ready mixed paint of specified shade or tint is not available while ready mixed paint with approved shade will be allowed. In such a case, the contractor shall ensure that the shade of the paint so allowed shall be uniform.

All the paints shall meet with the following general requirements

- (i) Paint shall not show excessive setting in a freshly opened full can and shall easily be redispersed with a paddle to a smooth homogeneous state. The paint shall show no curdling, livering, caking or colour separation and shall be free from lumps and skins.
- (ii) The paints as received shall brush easily, Possess good leveling properties and show no running or sagging tendencies.
- (iii) The paint shall not skin within 48 hour in a three quarters filled closed container.
- (iv) The paint shall dry to a smooth uniform finish free from roughness, grit, unevenness and other imperfections:

Enamel Paints:

The enamel paint shall satisfy in general requirements in specification of oil paints: Enamel paint shall conform to IS : latest edition.

French Polish

The French polish of required tint and shade shall be prepared with the below mentioned ingredients and other necessary materials

- (i) Denatured spirit of approved quality
- (ii) Chandras
- (iii) Pigment.

The French polish so prepared shall conform to IS: Latest edition.

Marble chips for marble mosaic terrazzo :

The marble chips shall be of approved quality and shades: It shall be hard, sound, dense and homogeneous in texture with crystalline and coarse grains. It shall be uniform in colour and free from stains, cracks, decay and weathering.

The size of various colour of marble chips ranging from the smallest upto 20 mm. shall be used where the thickness of top wearing layer is 6 mm. size. The marble chips of approved quality and colours only as per grading as decided by the Engineer-in-charge shall be used for marble mosaic tiles or works.

The marble chips shall be machine crushed. They shall be free from foreign matter, dust etc, except as above, the chips shall conform to IS latest edition.

M-47. Flooring Tiles :
(A). Plain Cement tiles

The plain cement tiles shall be of general purpose type. These are the tiles in the manufacture of which no pigments are used. Cement used in the manufacture of tiles shall be as per Indian Standards.

The tiles shall be manufactured from a mixture of cement and natural aggregates by pressure process. During manufacture, the tiles shall be subjected to pressure of not less than 140 Kg/Sq. Cm. The proportion of cement to aggregate in the backing of the tiles shall be-not less than 1:3 by weight. the wearing face though the tiles are of plain cement, shall be provided with stone chips of 1 to 2 mm. size. The proportions of cement to aggregate in the wearing layer of the tiles shall be three parts of cement to one parts chips by weight. The minimum thickness of wearing layer shall be 3 mm. The colour and texture of wearing layer shall be uniform throughout its face and thickness. On removal from mould, the tiles kept in moist condition continuously at least for seven days and subsequently, if necessary, for such long periods would ensure their conformity to requirements of IS. Latest edition regarding strength resistance to wear and water absorption.

The wearing face of the tiles shall be plane, free from projections, depressions and cracks and shall be reasonably parallel to the back face of the tile. All angles shall be right angle and all edges shall be sharp and true.

The size of tiles shall generally be square shape 24.85 Cm. x 24.85 Cm: or 25 Cm. x 25 Cm. The thickness of tiles shall be 20 mm.

Tolerance of length and breadth shall be plus or minus one millimeter. Tolerance on thickness plus 5 mm.

The tiles shall satisfy the tests as regards transverse strength, resistance to wear and water absorption as per I.S.: Latest edition.

(B) Plain Coloured Tiles:

These tiles shall have the same specification as for plain cement tiles as per (A) above except that they shall have a plain wearing surface wherein pigments are used. They shall conform to I.S. Latest edition.

The pigments used for colouring cement shall not exceed 10 percent by weight of cement used in the mix. The pigments, synthetic or otherwise, used for colouring tiles shall have permanent colour and shall not contain materials detrimental to concrete.

The colour of the tiles shall be specified in the item or as directed.

(C) Marble Mosaic Tiles:

The tiles same specification as per plain cement tiles except the requirements as stated below:

The marble mosaic tiles shall conform to I.S. latest edition. The wearing face of the tiles shall be mechanically ground and filled. The wearing face of tiles shall be free from projections, depressions and cracks and shall be reasonably parallel to the back face of the tiles. All angles shall be right angles and all edges shall be sharp and true.

Chips used in the tiles be from smallest upto 20 mm. size. The minimum thickness of wearing layer of tiles shall be 6 mm. For pattern of chips to be had on the wearing face, a few samples with or without their full size photographs as directed shall be presented to the Engineer-in-charge for approval.

Any particular samples, if found suitable shall be approved by the Engineer- in -charge, or he may ask for a few more samples to be presented. The samples shall have to be made by the contractor till a suitable sample is finally approved for use in the work. The Contractor, shall ensure that the tiles-supplied for the work shall be in conformity with the approved sample only, in terms of its dimensions thickness of backing layer and wearing surface, materials, ingredients, colour. shade chips, distribution etc. required.

The tiles shall be prepared for cement conforming to Indian Standards or coloured portland cement generally depending upon the colour of tiles to be or as directed.

(D) Chequered Tiles :

Chequered tiles shall be plain cement tiles or marble mosaic tiles. The former shall have the same specification as per (A) above and the latter as per marble mosaic tiles as per (C) except as mentioned below

The tiles shall be of nominal size of 250 mm. X 250 mm. if specified. The centre to centre distance of chequer shall not be less than 25 mm. and not more than 50 mm. The overall thickness of the tiles shall be 22 mm.

The grooves in the chequers shall be uniform and straight. The depth of the grooves shall not be less than 3 mm. The chequered tiles shall be plain, coloured or mosaic as specified. The thickness of the upper layer measured from the top of the chequers shall not be less than 6 mm. The tiles shall be given the first grinding with machine before delivery to site.

Tiles shall conform to relevant IS: latest edition.

(E) Chequered Tiles For Stair Cases :

The requirements of these tiles shall be the same as chequered tiles as per (D) above except in following respects :

(1) The length of a tile including nosing shall be 330 mm: (2) The minimum thickness shall be 28 mm: (3) The nosing shall have also the same wearing layer as at the top: (4) The nosing edge shall be rounded. (5) The front portion of the tiles for minimum length of 75 mm. from and including the nosing shall have grooves running parallel to nosing and at centers not exceeding 25 mm. Beyond that the tiles shall have normal chequer pattern.

M-48. Rough Kotah Stone :

The kotah stones shall be hard, even, sound and regular in shape and generally uniform in colour, The colour of the stone shall generally be green. Brown coloured shall not be use. They shall be without any soft veins, cranks or flaws.

The size of the stones to be used for flooring shall be of size 600 mm. X 600 mm. abd / or size 600 mm. X 450mm as directed. However smaller sizes will be allowed to be used to the extent of maintaining required pattern. Thickness shall be as specified.

Tolerance of minus 30 mm. on accounts of chisel dressing of edges shall be permitted for length as well as breadth. Tolerance in thickness shall be + 3 mm.

The edges of stones shall be truly chiselled and table rubbed with coarse sand before paving. All angles and edges of the stone of shall be true, square and free from chipping and the surface shall be true and plain.

When machine cut edges are specified, the exposed and the edges at joints shall be machine cut. The thickness of the exposed machine cut edges shall be uniform.

M-49. Polished Kotah Stones :

Polished kotah stone shall have the same specification as per rough kotah stone except as mentioned below:

The stones shall have machine polished surface. When brought an site, the stones shall be single polished or double polished depending upon its use. The stones for paving shall generally be single polished. The stones to be used for dedo, skiri thing sink, veneering, sills, steps, etc, where machine polishing after the stone are fixed in situ is not possible shall be double polished.

M-50. Dholpur Stone Slab :

Dholpur stone slab shall be of best quality as approved by the Engineer-in-charge: The stone slab shall be without any veins, cracks, and flaws. The stone slab be even, sound and durable regular in shape and of uniform colour.

The size of the stone shall be as specified in the item or detailed drawing of as approved by the Engineer-in-charge. The thickness of the stone shall be as specified in the item of work with the permissible tolerance of plus or minus 2 mm. the provisions in respect of polishing as for polished kotah stone shall apply to polished Dholpur stone also. All angles and edges of the face of the stone slab shall be fine chiselled or polished as

specified in the item of work and all the four edges shall be machine out. All angles and edges of the stone slab shall be true and plane.

The sample of stone shall be got approved by the Engineer-in-charge for a particular work. It shall be ensured that the stones to be used in a particular work shall not differ much in shade or tint from the approved sample.

M-51. Marble Slab :

Marble slab shall be white or of other and of best quality as approved by the Engineer-in-charge.

Slabs shall be hard close, uniform and homogeneous in texture. They shall have even crystalline grain and free from defects and cracks. The surface shall be machine polished to an even and perfect plane surface and edges machine cut true and square. The rear face shall be rough to provide key for the mortar.

Marble slabs with nature veins, if selected shall have to be laid as per the pattern given by the Engineer-in-charge. Size of the slab minimum 460 mm. X 450 mm: and preferably 600 min. X 600 mm. However smaller sizes will be allowed to be used to the extent of maintaining required pattern.

The slab shall not be thinner than the specified thickness at its thinnest part. A few specimen of finished slab to be used shall be deposited by the Contractor in the office for reference.

Except as above, the marble slabs shall conform to IS: Latest edition.

M-52. Granite Stone slab :

Granite shall be of approved colour and quality. The stone shall be hard, even sound and regular in shape and generally uniform in colour. It shall be without any soft veins, cracks or flaws.

The thickness of the stone shall be as specified in item.

All exposed faces shall be double polished tender truly smooth and even reflecting surface. The exposed edges and corners shall be rounded off as directed. The exposed edges shall be machine cut and shall have uniform thickness.

M-53. PVC Flooring

PVC sheet for PVC, floor covering shall be of homogenous flexible type, conforming to I.S. Latest edition. The PVC covering shall neither develop any toxic effect while put to use for shall give off any disagreeable odour.

Thickness of flexible type covering Tiles shall be as specified in the description of the item.

The flexible shall be backed with hessian or other woven fabric. The following tolerances shall be applicable on the nominal dimensions of the rolls or tiles :

(a) Thickness \pm 15 mm.

(b) Length of Width :

- | | |
|--|--|
| 1. 300 mm. square tiles \pm 0.20 mm | 3. 900 mm, square tiles \pm 0.60 mm, |
| 2. 600 mm. Square tiles \pm 0.40 mm. | 4. Sheets and roll \pm 0.10 percent. |

Adhesive:

The adhesive for PVC flooring shall be of the type and make recommended by the manufactures of PVC sheets/tiles.

M-54 Facing Tiles

The facing tiles (burnt clay facing bricks) shall be free from cracks and nodules of free lime. They shall be thoroughly burnt and shall have plane rectangular faces with parallel sides and sharps straight right angled faces.. The texture of the finished surface that will be exposed when in place shall conform to an approved sample consisting not less than four stretch bricks each representing the texture desired. The facing tiles shall have a pleasing appearance sufficient resistance to penetration by rain and greater durability than common bricks. The tiles shall conform to I.S.Latest edition.

The standard size of facing brick tiles shall be 19 x 9 x 4 cms. The facing brick tiles shall be provided with frog which shall conform to IS: Latest edition.

The permissible tolerance in dimensions specified above shall be as follows:

Size	Tolerance for	
	1st class brick	2nd class brick
19	± 6 mm	± 10 mm
9	± 3 mm	± 7 mm
4	± 1.5 mm	± 3 mm
The tolerance for distortion or warpage of face or edges of individual brick form a plane surface and from a straight line respectively shall be as follows:		
Facing dimensions		Permissible tolerance
Max. below 19 cms		Max 2.5 mm
--do-- above 19 mm		Max 3.0 mm

The average compressive strength obtained as a sample of five tiles when tested in accordance with the) procedure laid as per IS: Latest edition shall be not less than 175 Kg/Sq. Cm. The average compressive strength of any individual bricks shall be not less than 160 Kg/Sq. Cm.

The average water absorption for five bricks tiles shall not exceed 12 percent of average weight of brick before testing. The absorption for each individual bricks shall not exceed 25 percent.

The brick tiles when tested in accordance with IS: Latest edition, the rate of efflorescence shall not be more than "Slightly effloresced'

M-55. White glazed tiles

The tiles shall be of best quaky as approved by the Engineer- in-charge. They shall be foat and true to shape. They shall be free from cracks, crazing spots, chipped edges and corners. The glazing shall be of uniform shade.

Variation from the stated sizes, other than the thickness of tile shall be plus or minus 1.5 mm. The thickness of tile shall be 6 mm. Except as above the tiles shall conform to I.S. Latest edition.

M-56. Galvanized Iron Pipes and Fittings:

Galvanized iron pipe shall be of the medium type and of required diameter and shall comply with IS: latest edition. The specified diameter of the pipes shall refer to the inside diameter of the bore. Clamps, screw and all galvanized iron fittings shall be of the standard 'R' or equivalent make.

M-57. Bib cock and stop cock:

A bib cock is a draw off tap with a horizontal inlet and free outlet. A stop cock is a valve with a suitable means of connection for insertion in a pipeline for controlling or stopping the flow.

They shall be of screw down type and or brass chromium plated and of diameter as specified in the description of the item. They shall conform to IS: latest edition and they shall be of best Indian make. They shall be polished bright.

The minimum finished weight of bib cock and stop cock shall be as given below:

Diameter	Bib cock	Stop cock	Diameter	Bib cock	Stop cock
8 mm	0.25 kg	0.25 kg	15 mm	0.40 kg	0.40 kg
10 mm	0.30 kg	0.35 kg	20 mm	0.75 kg	0.75 kg

M-58. Gun metal wheel valve:

The gun metal wheel valve shall be of approved quality. These shall be of gun metal fitted with wheel and shall be of gate valve opening full way and of the size as specified. These shall conform to IS: latest edition.

M-59. White glazed porcelain wash basin:

Wash basin shall be of white porcelain first quality best Indian make and it shall conform to IS: latest edition. The size of the wash basin shall be as specified in the item. Wash basin shall be of one piece construction with continued over flow arrangements. All internal angles shall be designed so as to facilitate cleaning. Wash basin shall have single tap hole or two holes as specified. Each basin shall have a circular waste hole which is either revated or beveled internally with 65 mm diameter at top and 10 mm depth to suit the waste fitting. The necessary stud slot to receive the bracket on the under side of the basin shall be provided. Basin shall have an internal soap holder recess which shall fully drain into the bowl.

White glazed pedestal of the quality and color as that of the basin shall be provided where specified in the item. It shall be completely recessed at the back for reception of supply and wash pipe. It shall be capable of supporting the basin rigidly and adequately and shall be so designed as to make the height from the floor to top of the rim of basin 750 mm to 800 mm as directed.

M-60. European type water closet with low level flushing:

The European type water closet shall be white glazed porcelain first quality and shall be of wash down type conforming to IS: latest edition.

'S' trap shall be provided as required with water seal not than 50 mm. The solid plastic seal and cover shall be of best Indian make conforming to IS: latest edition. They shall be made of moulded synthetic materials which shall be tough and hard with high resistance to solvents and shall

be free from blisters and surface defects and shall have chromium plated brass hinges and rubber buffer of suitable size.

M-61. Orissa type water closet:

The specification of Orissa type white glazed water closet of first quality shall conform to IS: latest edition and relevant specification of Indian type water closet except that pan will be with the integral squatting pan of size 580 x 440 mm with raised footrest.

M-62. Indian type water closet:

The Indian type white glazed water closet of first quality shall be of size as specified in the item and conforming to IS: latest edition. Each pan shall have integral flushing. It shall also have an inlet at back or front for connecting flush pipe as directed. The inside of the bottom of the pan shall have sufficient slope from the front towards the outlet and surface shall be uniform and smooth. Pan shall be provided with 100 mm. diameter "P" or "S" trap with approximately 50 mm, Water seal and 50 mm. diameter vent horn.

A Foot Rests

A pair of white glazed earthen ware rectangular foot of minimum size 250 mm. x 130 mm x 20 min shall be provided with the water closet.

Glazed Earthen Ware Sink

The glazed earthen ware sink shall be of specified size, colour and quality. The sink shall conform to I. S. latest edition. The brackets for sinks shall conform to IS: latest edition.

The pipes shall conform to I.S. latest edition for steel and lead pipes respectively. 32 min. brass waste coupling of standard pattern with brass chain and rubber plug shall be provided with sink.

M-64. Glazed earthen-ware Lipped type flat back urinal / corner type urinal.

The lipped type shall be flat. back or corner type as specified in the item and shall conform to IS: Latest edition. It shall be of best Indian make and size as specified and approved by the Engineer-in-charge. The flat back or corner type urinal must be of 1st quality free from any defects, cracks etc.

M. 65. Low level enamel flushing tank

The low level enamel flushing tank shall be of 15 litres capacity. It shall conform to IS: latest edition. The flushing cistern shall be of best quality and free from any defects. The flushing tank shall have outlet 32 mm. diameter. The outlet shall be connected with WC. Pan by lead pipe or PVC pipe as specified. The flushing cistern shall be provided with inlet and outlet for fixing G.I. inlet pipes and overflow pipes The flushing cistern shall be provided with chromium plated handle for flushing. The flushing tank shall be provided with bracket of cast iron so that it can be fixed on wall at specified height. The, brackets shall conform to I.S. latest edition.

M-66. Cast iron flushing cistern.

The cast iron flushing cistern shall be of 15 litres capacity. It conform to IS. latest edition, The flushing cistern shall be of best quality free from any defects, The flushing cistern shall have outlet of 32 mm. diameter. The lead pipe shall conform IS: latest edition. For fixing G.I. inlet pipes and overflow pipe 20 mm dia inlet and outlet shall be got provided. The flushing, cistern shall be provided with galvanized iron chain and pull of sufficient length and shall be got approved from the engineer-in-charge. The cast iron flushing

cistern shall be painted with one coat of anti-corrosive paint and two coats of paints. The flushing cistern shall be fixed on two C.I. brackets. The C.I. bracket shall conform to IS: latest edition.

Flush Cock

Half turn flush cock (Heavy weight) shall be of gun metal chromium plated of diameter as specified in the description of the item. The flush cock shall conform to relevant Indian Standard.

Cast iron pipes and fittings.

All soil, water, vent and antisiphonage pipe and fitting shall conform to IS: latest edition. The pipe shall have spigot and socket ends with head on spigot end. The pipes and fittings shall be true to shape, smooth, cylindrical their inner and outer surfaces being as nearly as practicable concentric. They shall be sound and nicely cast and shall be free from cracks, laps pinholes or other imperfection and shall be neatly dressed and carefully settled.

The end of pipes and fittings shall be, reasonable square to their axis.

The sand cast iron pipes shall be of the diameter as specified in the description and shall be in lengths of 1.5 M, 1.8 M. and 2 M. including socket ends of the pipe unless shorter lengths are either specified or required at junctions etc. The pipes and fittings shall be supplied. without ears unless specified or directed otherwise.

Tolerances

The standard weights and thickness of pipes shall be as shown in the following table:

Sr No	Nominal dia. of bore	Thickness	Overall	Weight of pipe	Excluding ears
1	75 mm	5.0 mm	1.5 m long 12.83 kg	1.8 m long 16.52 kg	2 m long 18.37 kg
2	100 mm	5.0 mm	18.14 kg	21.67 kg	24.15 kg

A tolerance upto minus 15 percent in thickness and 20 mm in length will be allowed. For fittings tolerance in lengths shall be plus 25 mm and minus 10 mm.

The thickness of fittings and their socket and spigot dimensions shall conform to the thickness and dimensions specified for the corresponding sizes of straight pipes. The tolerance in weights and thickness shall be the same as for straight pipes.

M-69. Nahni Trap:

Nahni trap shall be of cast iron and shall be sound and free from porosity or other defects which affect serviceability. The thickness of the base metal shall not be less than 6.5 mm. The surface shall be smooth and free from craze, chips and other flaws or any other kind of defect which affect serviceability. The size of nahni trap shall be as specified and shall be of self cleaning design.

The nahni trap shall be of quality approved by the engineer-in-charge and shall generally conform to the relevant Indian Standard.

The nahn provided shall be with deep seal, minimum 50 mm except at places where trap with deep seal cannot be accommodated. The cover shall be cast iron perforated cover shall be provided on the trap of appropriate size.

M-70. Gully Trap:

The gully trap shall conform to IS: latest edition. It shall be sound, free from defects such as fire cracks or hair cracks. The glaze of the traps shall be free from crazing. They shall give a sharp clear note when struck with light hammer. There shall be no broken blisters.

The size of the gully trap shall be as specified in the item.

Each gully trap shall have one C.I. grating of square size corresponding to the dimensions, of inlet of gully trap. It will also have a water tight C.I. cover with frame inside dimension 300 mm x 300 mm. The cover with frame inside dimensions 300 mm x 300 mm the cover weighing not less than 4.53 kg and the frame not less than 2.72 kg. The grating cover and frame shall be of sound and good casting and shall have truly square machined seating faces.

M-71. Glazed stone ware pipe and fittings:

The pipes and fittings shall be of best quality as approved by engineer-in-charge. The pipe shall be of best quality manufactured from stoneware of fire clay, salt glazed thoroughly burnt through the whole thickness, of a close even texture, free from air blows, fire blisters, cracks and other imperfections, which affect the serviceability. The inner and outer surfaces shall be smooth and perfectly glazed. the pipe shall be capable to withstand pressures of 1.5 m head without showing sign of leakage. The thickness of the wall shall not be less than 1/12th of the internal dia. the depth of socket not be less than 38 mm. The socket shall be sufficiently large to allow a joint of 6 mm around the pipe.

The pipes shall generally conform to relevant IS latest edition.

M-72. Wall Peg Rail:

The aluminum wall peg rail shall have three aluminum pegs of approved quality and size. It shall be fixed on teak wood plank of size 450 mm x 20 mm. The teakwood shall be french polished or oil painted as specified.

M-73. G.I. Water Spot:

The G.I. pipes of 40 mm dia shall be of medium quality and specials shall be of 'R' brand or equivalent of the best approved quality.

The pipe shall have length as required for the thickness of wall in which it is fixed, and at outside end tee and bend cut at half the length shall be provided and at other end, coupling shall be provided to have better fixing. The water spout shall be provided as per detailed drawing or as directed.

M-74. Asbestos Cement Pipe (A.C. Pipe)

The asbestos cement pipe of diameter as specified in the description of the item shall conform to I.S. latest edition. Special like bends, shoes, cowl etc. shall conform to relevant Indian Standards. The interior of pipe shall have a smooth finish, regular, surface and regular internal diameter. The tolerance in all dimension shall be as per IS: latest edition.

M-75. Crydon Ball valve

Ball valve of screwed type including polythene float and necessary level etc. shall be of the size as mentioned in the description of item and shall conform to IS: latest edition.

M-76. Bitumen Felt For Water Proofing And Damp Proofing

Bitumen felt shall be on the fiber bases and shall be of type 2, self finished felt grade-2 and shall conform to IS: latest edition.

M-77. Selected Earth

The selected earth shall be that obtained from excavated material or shall have to be brought from outside as indicated in the item. If item does not indicate anything the selected earth shall have to be brought from outside.

The selected earth shall be good yellow soil and shall be got approved from the Engineer-in-charge. In no case black cotton soil or similar expensive and shrinkable soil shall be used. It shall be clean and free from all rubbish and perishable materials, stones or brick bats. The clods shall be broken to a size of 50 mm. or less. Contractor shall make his own arrangement at his own cost for land for borrowing selected earth. The stacking of material shall be done as directed by the Engineer-in-charge in such a way as not to interfere with any constructional activities and in proper stacks.

When excavated material is to be used, only selected stuff got approved from the Engineer-in-charge shall be used. It shall lie stacked separately and shall comply with all the requirements of selected earth mentioned above.

M-78. Barbed Wire.

The barbed wire shall be of galvanized steel and it shall generally conform to IS: latest edition. The barbed wire shall be of type-I whose nominal diameter for line wire shall be 2.5 mm and point wire 2.24 mm. The nominal distance between two barbs shall be 75 mm, unless otherwise specified in the item. The barbed wire shall be formed by twisting together two line wires, one containing the barbs. The size of the line and point wires and barb spacing shall be as specified above. The permissible deviation from the nominal diameter of the line wire and point wire shall not exceed 0.08 mm.

The barbs shall carry four points and shall be formed by twisting two point wires, each two turns, lightly round one line wire, making altogether four complete turns. The barbs shall be so finished that the four points are set and locked at right angles to each other. The barbs shall have a length of not less than 13 mm. and not more than 18 mm. The point shall be sharp and cut at an angle not greater than 35 degree of the axis of the wire forming the barbs.

The line and point wires shall be circular section, free from scale and other defects and shall be uniformly galvanized. The line wire shall be in continuous length and shall not contain any welds other than those in the rod before it is drawn. The distance between two successive splices shall not be less than 15 meters.

The lengths per 100 Kg. of barbed wire IS: type I shall be as under :
Nominal 1000 meters. Minimum 934 Meter. Maximum 1066 Meter.

Admixture for mass concrete and mortar:

M-79A) Joint Sealant

The sealant shall be best quality and from manufacturer like CICO, Fosroc MC-BAUCHEMIE, PIDILITE, HMP or equivalent as approved by engineer- in-charge. The prior approval for the source shall be taken from the engineer-in-charge. It shall be conformed to the relevant I.S. Code.

It shall be two component polysulphide rubber joint sealant, based on a low molecular weight polymer. It should not contain chloride or other corrosive substances.

It shall be used for sealing joints in water retaining structure, roofs, external wall, cladding, floors, partition, sealing, pavement surface etc. It shall have excellent property to adhere most of building material like aluminum, stainless steel, glass, concrete, marble, stone, brick, masonry block, plaster, ceramic, quarry tiles, timber etc. The modulus of elasticity of the sealant shall be less than 0.16 MPa, $\pm 10\%$ at 100% elongation. The shore "A" hardness of the sealant shall be 22 ± 3 @ 250C.

The operating temperature range for the sealant shall be 250C to 800C. The permanent dynamic movement capability of the sealant shall be $\pm 25\%$. The tensile strength of the sealant shall not be less than 0.4 MPa. The optimum width / depth ratio shall be 2:1. The specific gravity of the sealant shall be 1.6 Kg/Lit. The sealant should be capable to resist to attack of water, sunlight, oxidation, corrosive fumes, oils, petrol, diluted acids and alkalies, salt spray, aliphatic and aromatic solvent and shall not contain tar or bituminous ingredients.

It shall possess the properties like 550% elongation at break, non-toxicity when fully cured, no staining and shrinkage less than 1%. The trafficable strength shall be achieved within 24 hours and full at 7 days (at 250C and 250% RH). It shall possess excellent coverage capacity and more strength at low dry temperature.

M-79B) Abrasion Resistant Industrial Flooring Aggregate:

The flooring aggregate shall be of best quality and from manufacturer like CICO, Fosroc or equivalent, as approved by the engineer-in-charge. The prior approval for the source shall be taken from the engineer-in- charge. It shall be conformed to the relevant I.S. Code.

The flooring aggregate shall be factory processed and specially graded non-oxidized, non-magnetic and chemically inert metallic flooring aggregate, free from oil and grease.

It shall be used as a surface hardener to concrete floors. It is recommended for factory floors, warehouses, hangers, car parks and such other areas subjected to heavy vehicular traffic. It shall also be used on open and continuously wet surfaces. The flooring aggregate shall build in wearing resistance and shall produce high abrasion resistant floor surfaces. It shall impart extreme surface density and shall offer resistance to oil and water penetration. It shall provide a non-rusting floor surface which is easy to maintain.

It shall be used with cement in the ratio, as per manufacturer's instruction and spread evenly on the surface to be treated, at the rate depending on the type of floor. The flooring aggregate shall be spread when the surface of the concrete floor is still fresh, i.e. as soon as the surface water has evaporated and then trowled, in stage, to bring about a uniform and smooth finish.

M-79C Concrete Hardener and Dust Proofer :

The concrete hardener and dust proofer, shall be of the best quality and from manufacturer like CICO, Fosroc or equivalent, as approved by the engineer-in-charge. The prior approval for the source shall be taken from the engineer-in-charge. It shall be conformed to the relevant I.S. Code.

It shall have a specific gravity of 1.18 and shall be applied on concrete floors, at the rate of at least 25 liter/100 m²/coat. A total of 3 coats shall be applied for permanently hardened concrete floor, with increased abrasion resistance, increased surface density, increased resistance to chemical attack and to eliminate dust accumulation. Drying time of 4 to 6 hours for each coat shall be allowed before the flooring is put to use or is applied with another coat of the product. Precautions shall be taken while using the product, to avoid contact with eye and open wounds and to work in good ventilation. After application, the affected part shall be washed copiously. It shall not be stored for the period of more than two months before use.

M-79D Water Repellent Coating :

The water repellent coating shall be of the best quality and from manufacturer like CICO, Fosroc or equivalent, as approved by the engineer-in-charge. The prior approval for the source shall be taken from the engineer-in-charge. It shall be conformed to the relevant I.S. Code.

Water repellent coatings for exterior exposed surfaces shall be acrylic resin based, having a Flash point of approx. 40°C and specific gravity of 0.95.

It shall be suitably used for concrete, brick, stone and plastered surfaces preventing moisture penetration and thus any damage to the interiors. It shall be quick acting, long lasting, invisible i.e. colourless so as to maintain the original colour of the surface treated. It shall impart sealing characteristics so that the treated surface becomes stain and dust free. The coating itself shall not darken or turn yellow with age.

M-79E Accelerating, Water Reducing Admixture and Plasticiser :

The Accelerating, Water reducing admixture and plasticiser, shall be of best quality and from manufacturer like CICO, Fosroc or equivalent, as approved by the Engineer. The prior approval for the source shall be taken from the Engineer. It shall conform to the relevant IS Code.

It shall be in liquid state with a specific gravity of 1.30 and complying with-ASTM C-494 Type E, IS : 9103 & IS: 2645. It shall accelerate the setting and hardening of the concrete mix, thereby achieving higher early age strength. It shall reduce the water content of the concrete without affecting its workability. It is useful for pre-cast/pre-stressed works, structural concrete works, floors, roads, runways, paving etc. It shall be used at the rate instructed by the manufacturer, with cement, depending on the amount of acceleration of hardening required, it should be compatible to all types of cement.

M-79F Retarding, Water Reducing Admixture and Plasticiser :

The Retarding, water reducing admixture and plasticiser, shall be of best quality and from - manufacturer like CICO, Fosroc, Feb Roffe or equivalent, as approved by the Engineer. The prior approval for the source shall be taken from the Engineer. It shall conform to the relevant IS Code.

It shall be in liquid state with a specific gravity of 1.22 and complying with ASTM C-494 Type B & D, IS 9103, CRD-C87 Type B & D, BS 5075 Part 1. It shall be added to the concrete mix during the mixing process, at the same time as the water or the aggregates. No extension of normal mixing time is necessary. It shall extend the period of time as to placing the concrete and compacting, i.e. delay the initial and final setting time. It shall help to spread the heat of hydration over a longer period of time. It shall give a highly workable concrete with a low W/C ratio. It shall

be used at the rate instructed by the manufacturer, with cement, depending on the amount of acceleration of hardening required. It should be compatible to all types of cement.

M-79G Water & Weather Proof Compound :

The water & weather proof integral cement admixture shall be of best quality and from manufacturer like Feb Roffe's Roff Hyseal, Roff hyproof, Algiproof or equivalent, as approved by the Engineer. The prior approval for the source shall be taken from the Engineer. It shall conform to the relevant IS Code.

It shall be used as an excellent cement admixture in all types of concrete/plaster mortars, pointing mortars, masonry works, guniting works and pressure grouting works. It shall improve resistance of concrete surfaces to weathering and chemical attack. It shall be non-toxic so as to use for water proofing water tanks, reservoirs, bio-gas tank, leaking ceiling, basements, tunnels, lift wells etc.

It shall be mixed to concrete or plaster mortar, while mixing. First, water is added and then the admixture, at the rate instructed by the manufacturer. For use of the admixture, precaution shall be taken to use clean materials for preparation of mortar.

M-79H Plaster Admixture :

An admixture which gives the plaster workability, durability and quality at an economical rate shall be of best quality from manufacturer like Feb Roffe (product name - Roff plaster master) or equivalent, as approved by the Engineer. It shall comply to the relevant IS Codes.

It shall keep the plastering mortar plastic for a longer time, giving higher strength on prolonged curing. It shall provide cohesiveness, workability and eliminate efflorescence. It shall reduce shrinkage, cracking and crazing to the minimum.

Fly Ash :

Fly Ash of grade-I as per IS: 3812-1981 shall be from Sikka Thermal Power Station Only. Contractor has to manage for required size containers at site work for storing the Fly ash.

Anti-Corrosive Paints : M-81A Ferro shield:

It shall be from STP Limited or equivalent, as approved by the Engineer.

It shall be a high build bituminous emulsion, specially formulated for protection against corrosion. It shall form a dry film, 2 mm. thick, which shall not crack at low temperatures nor crocodile at-very high temperatures. It shall also be used as waterproofing material on flat, sloped and steeped roofs. It shall be applied by brush and by heavy duty airless spraying. ..

M-81B Tank mastic:

It shall be from STP Limited or equivalent, as approved by the Engineer. It shall conform to IS :158- 9862.

It shall be special bituminous paint, which shall have no harmful reaction on drinking water. It shall be used to protect the inside of water tanks and pipe connections, against corrosion. It shall be applicable on steel, wood, concrete, iron etc. It shall have a covering capacity of 12 m²/lit..

M-81C Pipe kote:

It shall from STP Limited or equivalent, as approved by the Engineer. It shall conform to IS: 158.

It shall be a heavy duty bituminous paint, which shall not impart any odour or taste to water, carried in the steel water pipelines, tanks and pen-stocks. It shall be applied on the inside surface of the water pipe line, tanks and pen-stocks. It shall be resistant to mild acids, alkalis and shall withstand heat upto 150°C. It shall render a heavy body protective film. If zinc-rich, epoxy primer shall be used, better results of pipe kote shall be obtained.

M-81D Silver Shield:

It shall be from STP Limited or equivalent, as approved by the Engineer.

It shall be a bituminous aluminum-finish paint formulated for application over anti-corrosive paints. It shall have a covering capacity of 10 m²/lit..

M-81E Shali mastic HD:

It shall be from STP Limited or equivalent, as approved by the Engineer. It shall comply with the US Dept. of interior bureau of reclamation specification CA-50.

It shall be a viscous, heavy-duty, anti-corrosive waterproof coal tar paint. It shall offer resistance to acids and alkalis. It shall be used for protection of all types of iron and steel structures.

Galvanized Iron Pipe:

Galvanised iron pipe shall be of the medium type and of required diameter and shall comply with IS 1239-1975. The specified diameter of the pipes shall refer to all inside diameter of the bore, clamps, screw and all galvanised iron fittings shall be of standard 'R' or equivalent make as approved by the Engineer.

Acoustical Wall & Ceiling material :-**M-83a Glass wool:-**

- I. Glass wool shall be conform as per relevant I.S. standard & specification.
- II. Density, & thickness shall be used as per specified in item specification.
- III. It shall be pure without dust & any foreign matter and shall be uniform in color, density & weight.

M-83b Aluminum foil or percolated sheet:-

- I. Aluminum alloy used in the manufacture of extruded & sheet or section shall conform to I.S. designation HEA-WP of I.S. 733- 1975 and also to I.S. designation WVG-WP of I.S. 1285- 1975. & it shall be specified in the item specification. The fabrication shall be done as directed.
- II. Aluminum shall be conform to I.S.733-1825, & relevant I.S. standard & specification.
- III. Density, Grade & thickness shall be used as per specified in item specification.

M-83c Wood wool board :-

- I. Acoustical Insulation shall be conforming to I.S. 8225-1987, and equivalent to ISO: 354 & ASTM. 423-90 A.
- II. Thermal insulation shall be conform to B.S. :874 – 1965.
- III. Board shall be fire resistant conform to B.S. 476- part-5 Class-P, part-6 I-4.11, Part-7 Class-1, & size, thickness and other special requirement shall be as per specified in item specification.

M-83d Acoustical Board & Gypsum board

Humidity resistant	99 % RH.
Material fire performance	Class- 0/ Class-1 (B.S. 476)
Sound Absorption (NRC.)	0.50
Frequency Hz	125 – 4000
Sound insulation	40dB.
CAC.	90%
Light reflection.	>85%
Thermal resistant.	$R=0.28 \text{ m}^2 \text{ k/W}$
Weight / Piece (600mm X 600mm. X 15mm. thick board without Grid.)	2.35 Kg.

Surface finish	Crisp subtly textured matt appearance with visible perforation finished with vinyl emulsion paint
Material	Hydro synthesized Bio soluble long fiber with purified starch as binder.
Bending strength	$\geq 250\text{N}$ (JIS A 6301)
Sagging resistant	$\leq 5/1000$.

Testing Method

Fire Propagation Test	Class – 0	B.S. 476 PART- 6
Flame spread	Class 1 (0-25)	ASTM – E84
	Class-A	U.S. Federal Spec. SS.-S-118-b
	20	Underwriters Laboratories Inc.
	Class-1	BS. 476 Part-7
Thermal conductivity	0.045 Kcal/mh ⁰ C	JIS A 1412
Light reflectance	LR-1 (Over 80%)	ASTM. C 523
NRC	0.55-0.70	ASTM. C 423
CAC	36	ASTM. E 413

- I. Size, thickness and other special requirement shall be specified in the item specification. The fabrication shall be done as directed.

Signature of Contractor

DETAILED TECHNICAL SPECIFICATIONS

Item No.1& 2 & 3 & 11 Schedule B1 & Item No.8 Schedule B2 & Item no-8&9 & 10& 11&20 &25 Schedule B3:

Removal of flooring & Removal of Block & Removal of Door/Window & Removal of Cement/Lime plaster & Dismantling of super structure & disposing it in RMC area & Dismantling Cement concrete or RCC Disposing it in RMC area

1. The work shall consist of removing, as herein after set forth; existing culverts, bridges, pavement, kerbs and other structures like guards-rails, fences, utility poles, manholes, catch basins, inlets, etc. Which are in place but interfere with the new construction or are not suitable to remain in place and of salvaging and disposing of the resulting materials and back-filling the resulting trenches and pits.
2. Existing culverts, bridges, pavements and other structures which are within the work area and which are designated to be removed, shall be removed up to the limits and extent specified in the drawings or as indicated by the Engineer-in-charge.
3. Dismantling and removal operations shall be carried out with such equipment and in such a manner as to leave undisturbed, adjacent pavement, structures and other work to be left intact.
4. All operations necessary for the removal of any existing structure which might endanger new construction shall be completed prior to the start of new work.
5. The structures shall be dismantled carefully and the resulting materials so removed as not to cause any damage to the serviceable materials to be salvaged, the part of structure to be retained and any other properties or structures nearby.
6. Unless otherwise specified, the superstructure portion of culverts / bridges shall be entirely removed and other parts removed to below the ground level or as necessary depending upon the interference they caused to the new construction. Removal of overlying of adjacent material if required in connection with the dismantling of the structures shall be incidental to this item.
7. Where existing culverts / bridges are to be extended or otherwise incorporated in the new work only such part or parts of the existing structure shall be removed as are necessary to provide a proper connection to the new work. The connecting edges, shall be cut, chipped and trimmed to the required lines and grades without weakening or damaging any part of the structure to be retained. Reinforcing bars which are to be left in place so as to project into new work as dowels or ties shall not be injured during removal of concrete.
8. Pipe culverts shall be carefully removed in such a manner as to avoid damage to the pipes.
9. Steel structures shall unless otherwise provided be carefully dismantled in such a manner as to avoid damage to members thereof. If specified in the

drawing or directed by the Engineer-in-charge that structure is to be removed in a condition suitable for re-erection, all members shall be match marked by the contractor with white lead paint before dismantling. End pins, nuts, loose, plates, etc. shall be similarly marked to indicate their proper location. All pins, pin holes and machined surfaces shall be painted with a mixture of white lead and tallow and loose parts shall be securely wired to adjacent members or packed in boxes.

10. Timber structures shall be removed in such a manner as to avoid damages to such timber or lumber as is designated by the Engineer -in-charge to be salvaged.
11. In removing pavements, kerbs, gutters, and other structures, like guard rails, fences, manholes, catch, basins, inlets etc. where portions of the existing construction are to be left in the finished work, the same shall be removed to an existing joint or cut and chipped to a true line with a face perpendicular to the surface of the existing structure. Sufficient removal shall be made to provide for proper grades and corresponding with the new work as directed by the Engineer-in-charge.
12. All concrete pavements base course in carriageway and shoulders etc. designated for removal shall be broken to pieces whose volumes shall not be exceed 0.02 cubic meter and, stockpiled at designated locations if the material is to be used later or otherwise arranged for disposal as directed.
13. Where directed by the engineer-in-charge holes and depressions caused by dismantling operations shall be backfilled with excavated or other approved material and thoroughly compacted in line with surrounding area.
14. All materials obtained by dismantling shall be the property of Government. Unless otherwise specified, materials having any salvage value shall be placed in neat stack of like material within the right-of- way as directed by the Engineer-in-charge, for which contractor will remain responsible for its safe custody and preservation for 60 days after recording measurements of the salvaged material.
15. Pipe culverts that are removed shall be cleared and neatly piled on the right-of-way at points designated by the Engineer-in-charge.
16. Structural steel removed from old structure shall, unless otherwise specified or directed be stored in a neat and presentable manner on blocking in locations suitable for loading. Structures or portions thereof which are specified in the contract for re-erections shall be stored in separate piles.
17. Timber of lumber from old structures which is designated by the Engineer-in-charge as materials to be salvaged shall have all nuts and bolts removed from and shall be stored in neat piles in locations suitable for loading.
18. All the products of dismantling operations which in the opinion of the Engineer-in-charge cannot be used or auctioned shall be disposed as directed, within 100 meters.

19. The work of dismantling structure shall be paid for in units indicated below by taking measurement before and after, as applicable;
- | | | | |
|-------|---|-------|--------------|
| i) | Dismantling brick / stone / concrete
(Plain and reinforced) masonry(super structure) | Cubic | Meter |
| ii) | Dismantling flexible and cement
concrete pavement | Cubic | Meter |
| iii) | Dismantling steel structure | Ton | |
| iv) | Dismantling timber structure | Cubic | Meter |
| v) | Dismantling pipes, guard rails, kerbs,
gutters and fencing | | Linear Meter |
| vi) | Utility poles | | No.s |
| vii) | Removal of flooring – CC Precast Tiles /
Shahbadi ladi / tiles flooring | | Sqr. Mtr |
| viii) | Removal of road divider strip | | No.s |
| ix) | Removal of block | | Sqr. Mtr |
| x) | Removal of Door/window | | No.s |
| xi) | Removal of Cement/Lime plaster | | Sqr. Mtr |

20. The contract unit rates for the various items of dismantling shall befor payment in full for carrying out the required operations including full compensation for all labor, materials, tools equipment, safeguard and incidentals necessary to complete the work. These will also include excavation and backfilling where necessary and for handling, salvaging, pilling and disposing of the dismantled material within all lifts and up to a lead of 100 meters.

Item No.4 Schedule B1 & Item No. 1 Schedule B2 & Schedule B3:

Excavation of Foundation in Soft Murrum. Soil or Sand from 0.0 mtr.to 1.50 mtr depth including lifting and laying as instructed

1.0 General:

- 1.1 Any soil which generally yields to the application of the pickaxes and shovels, phawaras rakes or any such ordinary excavation implement or organic soil, gravel, slit, sand turf lawn, clay, peat etc. fall under this category.

2.0 Cleaning the site:

The site on which the structure is to be built shall be cleared, and all obstructions, loose stone, materials and rubbish of all kind, bush, wood and trees shall be removed as directed. The materials so obtain shall be property of the government and shall be conveyed and stacked as directed within RMC limit. The roots of the tree coming in the sides shall be cut and coated with a asphalt.

- 2.2 The rate of site clearance is deemed to be included in the rate of earth work for which no extra will be paid.

3.0 Setting out:

After clearing the site, the center lines will be given by the engineer-in-charge. The contractor shall assume full responsibility for alignment, elevation and dimension and of each and all parts of the work. Contractor shall supply labors, materials, etc required for setting out the reference marks and bench marks and shall maintain them as long as required and directed.

4.0 Excavation:

The excavation in foundation shall be carried out in true line and level and shall have the width and depth as shown in the drawings or as directed. The contractor shall do the necessary shoring and strutting or providing necessary slopes to a safe angle, at his own cost. The bottom of the excavated area shall be leveled both longitudinally and transversely as directed by removing and watering as required. No earth filling will be allowed for bringing it to level, if by mistake or any other reason excavation is made deeper or wider than that shown on the plan or directed. The extra depth or width shall be made up with concrete of same proportion as specified for the foundation concrete at the cost of the contractor. The excavation upto 1.5 mt depth shall be measured under this item.

5.0 Disposal of the excavated stuff:

The excavated stuff of the selected type shall be used in filling the trenches and plinth or leveling the ground in layers including ramming and watering etc.

The balance of the excavated quantity shall be removed by the contractor from the site of work to a place as directed within RMC limit and all lift.

After refilling, surplus earth shall have to carted by the contractor within specified limit including loading transporting unloading spreading without any extra cost.

The surplus stuff shall be disposed off at the following sites as directed within the prescribed limits of Notification as directed by the engineering in charge.

1. Beside Kotharia Police Station near Stone Quarry
2. All Quarry areas of Raiya Smart City

If the contractor fails to dispose the excavated stuff as specified, penalty will be imposed by Rajkot Municipal Corporation as per the Notification for C&D waste.

Mode of Measurement and Payment:

The measurement of excavation in trenches for foundation shall be made according to the sections of trenches shown on the drawing or as per sections given by the engineer-in-charge. No payment shall be made for surplus excavation made in excess of above requirement or due to stopping and sloping back as found necessary on account of conditions of soil and requirements of safety.

The rate shall be for a unit of one cubic Meter.

Item No.5 Schedule B1& Item No.2 Schedule B2& Schedule B3 :
Foundation filling with CC work in proportion of 1:3:6 using 1.5cm to 2.0 cm aggregate including Ramming, Curing etc.& Foundation filling with CC work in proportion of 1:2:4 using 1.5 cm to 2.0 cm aggregate including Ramming, Curing etc.

- 1.0. Materials
- 1.1 Water shall conform to M-1. Cement shall conform shall conform to M-3. Sand shall conform to M-6. Stones aggregate 20 mm. nominal size shall conform to M- 12.
- 2.0 Workmanship
- 2.1 General
- 2.1.1 Before starting concrete the bed of foundation trenches shall be cleared of all loose materials, leveled, watered and rammed as directed.
- 2.2 Proportion of Mix
- 2.2.1 The proportion of cement, sand and coarse aggregate shall be one part of cement, 2 parts of sand and 4 parts of stone aggregate; and shall be measured by volume.
- 2.3 Mixing
- The concrete shall he mixed in a mechanical mixer at the site of work. Hand mixing may however be allowed for smaller quantity of work if approved by the Engineer-in-charge. When hand mixing is permitted by the Engineer-in-charge in case of break-down of machineries and in the interest of the work, it shall be carried out on a water tight platform and care shall be taken to ensure that mixing is continued until the mass is uniform in colour and consistency. However in such cases 10% more cement than otherwise required shall have to be used without any extra cost. The mixing in mechanical mixer shall be done for a period 1½ to 2 minutes. The quantity of water shall be just sufficient to produce a. dense concreteof required workability for the purpose.
- 2.4 Transporting & placing the concrete.
- The concrete shall, be handed from the place of mixing to the final position in not more than 15 minute by the method as directed and shall be placed into its final position, compacted and finished within 30 minutes of mixing with water i.e. before the setting commences.
- 2.4.1 The concrete shall be laid in layers of 15 cms to 20 cms.
- 2.5 Compacting:
- 2.5.1 The concrete shall be rammed with heavy iron rammers and rapidly to get the required compaction and to allow all the interstices to be filled with mortar.
- 2.6 Curing
- 2.6.1 After the final set, the concrete shall be kept continuously wet if required by ponding for a period of not less then 7 days from the date of placement.
- 2.7 Mode of measurements and payment:
- 2.7.1 The concrete shall he measured for its length, breadth, and depth, limiting dimensions to those specified on plan or as directed.
- 2.7.2 The rate shall be for a unit of one cubic meter.

Item No.3 & 4 & 5 & 6 & 7 Schedule B2 & Schedule B3 :
CC work M-20 for RCC footing using aggregate of size 10-20 mm. centring, curing, finishing etc. complete (without reinforcement) & CC work M-20 for Column using aggregate of size 10-20 mm, centring, curing, finishing etc. complete (without reinforcement) & CC work M-20 for Beam using

aggregate of size 10-20 mm, centring, curing, finishing etc. complete (without reinforcement) & CC work M-20 for RCC slab using aggregate of size 10-20 mm, centring, curing, finishing etc. complete (without reinforcement) & CC work M-20 for Chhajja using aggregate of size 10-20 mm, centring, curing, finishing etc. complete (without reinforcement)

- A: Flat bottom slab or slab/slab with shuttering
- B: Above 15 cm to 20 cm
- C: Above 25cm

All RCC work is to be carried out through ready mix design as approved by engineer-in-charge.

1.1 Design Submissions

Complete detailed design calculations of foundations and superstructure together with general arrangement drawings and explanatory sketches shall be submitted to Addl. City Engineer. Separate calculations for foundations or super structures submitted independent of each other shall be deemed to be incomplete and will not be accepted by Addl. City Engineer.

The design considerations described hereunder establish the minimum basic requirements of plain and reinforced concrete structures, masonry structures and structural steel works. However, any particular structure shall be designed for the satisfactory performance of the functions for which the same is being constructed. The Contractor shall also take care to check the stability of partly completed structures.

1.2 Design Standards

All designs shall be based on the latest Indian Standard (I.S.) Specifications or Codes of Practice. The design standards adopted shall follow the best modern engineering practice in the field based on any other international standard or Specialist literature subject to such standard reference or extract of such literature in the English language being supplied to and approved by Addl. City Engineer. In case of any variation or contradiction between the provisions of the I.S. Standards or Codes and the specifications given along with the submitted tender document, the provision given in this Specification shall be followed.

All reinforced concrete structural design shall generally conform to the following publications of the Indian Standards Institution:

- I.S.456 Code of Practice for plain and reinforced concrete
- I.S. 875 Code of Practice for design loads for buildings and structures (Part 1 to 5)
- I.S. 3370 Code of Practice for concrete structures for the storage of liquids (Part I to IV)
- I.S.1893 Criteria for earthquake resistant design of structures
- I.S. 2974 Code of Practice for design and construction of machine foundations (Part 1 to 4)

All structural steel design shall generally conform to the following publications of the Indian Standards Institution:

- I.S.800: Code of Practice for general construction in steel
 I.S. 806: Code of Practice for use of steel tubes in general building construction

1.3 Design Life

The design life of all structures and buildings shall be 60years.

1.4 Design Loading

All buildings and structures shall be designed to resist the worst combination of the following loads / stresses under test and working conditions; these include dead load, live load, wind load, seismic load, stresses due to temperature changes, shrinkage and creep in materials, dynamic loads, impact load and other specific loads.

1.4.1 Dead Load

This shall comprise all permanent construction including walls, floors, roofs, partitions, stairways, fixed service equipment and other items of machinery.

The following minimum loads shall be considered in design of structures :

Weight of water	9.81kN/m ³
Weight of soil (irrespective of strata available at site and type of soil used for filling etc). However, for checking stability against uplift, actual weight of soil as determined by field test shall be considered.	20.00kN/m ³
Weight of plain concrete	24.00kN/m ³
Weight of reinforced concrete	25.00kN/m ³
Weight of brick work(exclusive of plaster)	22.00N/m ² per mm thickness of
Weight of plaster to masonry surface	18.00N/m ² per Mm thickness
Weight of granolithic terrazzo finish or rendering screed, etc.	24.00N/m ² per mm thickness

1.4.2 Live Load

Live loads shall be in general as per I.S. 875. However, the following minimum loads shall be considered in the design of structures:

- i) Live load on roofs (accessible) : 1.50 kN/m²
 (Non-Accessible) : 0.75 kN/m²
 Live Load on Floors Supporting

	Equipments such as pumps, Blowers Compressors, valves, etc.	:	10.00 kN/m ²
ii)	Live load on other floors walkways , stairways and platforms	:	5.00 kN/m ²

In the absence of any suitable provisions for live loads in I.S. Codes or as given above for any particular type of floor or structure, assumptions made must receive the approval of Addl. City Engineer prior to starting the design work. Apart from the specified live loads or any other load due to material stored, any other equipment load or possible overloading during maintenance or erection / construction shall be considered and shall be partial or full whichever causes the most critical condition.

1.4.3 Wind Load

Wind loads shall be as per I.S.875.

1.4.4 Earthquake Load

This shall be computed as per I.S. 1893 considering earthquake 2001. An importance factor appropriate to the type of structure shall be considered for design of all the structures.

1.4.5 Dynamic Load

Dynamic loads due to working of items such as pumps, blowers, compressors, switch gears, travelling cranes, etc. shall be considered in the design of structures as per manufacturer's data.

1.5 Joints

Movement joints such as expansion joints, complete contraction joints, partial contraction joints and sliding joints shall be designed to suit the structure. However, contraction joints shall be provided at specified locations spaced not more than 7.5 m in both right angle directions for all walls and rafts.

Expansion joints of suitable gap at suitable intervals not more than 30 m shall be provided in all walls, floors and roof slabs of water retaining structures.

Construction joints shall be provided at right angles to the general direction of the member. The locations of construction joints shall be decided on convenience of construction. To avoid segregation of concrete in walls, horizontal construction joints are normally to be provided at every 2-m height. PVC water-stops of 150 mm width shall be used for walls and 230 mm width for base slabs. Alternatively contractor can use G.I. Sheets of 18 gauge and 200 mm wide.

Expansion joints for non-liquid retaining structures shall be provided as per IS 3414.

1.6 Design Conditions for Underground or Partly Underground Liquid Retaining Structures

All underground or partly underground liquid containing structures shall be designed for the following conditions:

- (i) Liquid depth to be considered up to full height of wall and no relief due to soil pressure from other side to be considered.
- (ii) Structure empty condition (i.e., empty of liquid, any material, etc.): full earth pressure with saturation and surcharge pressure wherever applicable, to be considered.
- (iii) Partition wall between dry sump and wet sump to be designed for full liquid depth up to full height of wall.
- (iv) Partition wall between two compartments : to be designed as one compartment empty and other full for both the directions.
- (v) Structures shall be designed for uplift in empty conditions with no live load with the appropriate water table.
- (vi) Walls shall be designed under operating conditions to resist earthquake forces from earth pressure mobilization and dynamic water loads.
- (vii) Underground or partially underground structures shall also be checked against stresses developed due to any combination of full and empty compartments with appropriate ground/uplift pressures from below to base slab. A minimum factor of 1.2 shall be ensured against uplift or floatation.
- (viii) For tender evaluation, the Soil bearing capacity is to be consider 10 MT/Sq.mt for sump and pump house foundation but on award of the work, contractor shall have to carry out detailed soil analysis & based on actual S.B.C. structure shall have to be designed.

1.7 Foundations

- (i) The minimum depth of foundations for all structures, equipment, buildings and frame foundations and load bearing walls shall be as per IS 1904.
- (ii) Maximum safe bearing capacity of soil strata shall be taken as indicated in geo-technical reports.
- (iii) Care shall be taken to avoid the foundations of adjacent buildings or structure foundations, either existing or not within the scope of this Contract. Suitable adjustments in depth, location and sizes may have to be made depending on site conditions. No extra claims for such adjustments shall be accepted by Addl. City Engineer.
- (iv) Special attention shall drawn to danger of uplift being caused by the ground water table. Localised water table shall be consider up to existing ground level. Also Ground water table of said plot shall be study in advance inclusive of rain water/other water deposition effect to foundation. That shall be consider in design and implementation of foundation and bottom slab of structure regarding absolute resistation against uplift pressure.
- (v) All ground level structural slab wherever applicable shall be designed for uplift forces due to ground water pressure.
- (vi) Where there is level difference between the natural ground level & the foundations of structure or floor slabs, this difference shall be filled up in the following ways:
 - In case of non-liquid retaining structures the natural top soil

shall be removed till a firm strata is reached (minimum depth of soil removed shall be 500 mm.) and the level difference shall be made up by compacted backfill as per specifications. However the thickness of each layer shall not exceed 150 mm. The area of backfilling for floor slabs shall be confined to prevent soil from slipping out during compaction. The safe bearing capacity of this well compacted backfilled soil shall not exceed 100 kN/sq.m.

- In case of liquid retaining structures, the natural top soil shall be removed as described above and the level difference shall be made up with Plain Cement Concrete (1:5:10)

i) Design Requirements

The following are the design requirements for all reinforced or plain concrete structures:

- a) All binding and leveling concrete shall be a minimum 100 mm thick in concrete grade 1:3:6.
- b) All water retained structure are make M-30 grade mix concrete with a maximum 20 mm aggregate size for footings and base slabs and all other structural members. The structures shall have to be designed as per IS : 3370 (Part I-IV).
- c) The reinforced concrete for water retaining structures for M-30 grade mix concrete shall have a minimum cement content of 400 kg/m^3 with a maximum 20 mm size aggregate as per IS : 3370 (Part I-IV).
- d) The minimum reinforcement for water retaining structures in each direction should be 0.35% of cross section. The minimum clear cover to all reinforcement including stirrups and links shall be 50mm for all water retaining structures.
- e) All buildings shall have a minimum 1 metre wide, 100mm thick plinth protection paving in M15 grade concrete or stone slabs/tiles. All plinth protection shall be supported on well compacted strata.
- f) Any structure or pipeline crossing below roads shall be designed matching classification of road (anything from Class A to AA of IRC loading)
- g) The bridges & bridge supporting structures shall be designed to safely withstand the loading.
- h) All pipes & conduits laid below the structural plinth & road works shall be embedded in reinforced concrete of grade M15 of minimum thickness 150 mm.
- i) Approved quality waterproofing compound (chloride free) shall be added during concreting of all liquid containing structure in the proportions specified by manufacturer or 2% by weight of cement which ever is higher.

- The wall and floor panels shall be poured in sequential order with a minimum time gap of 4 days.

The following minimum thickness shall be used for different reinforced concrete members, irrespective of design thickness:

(i) Walls for liquid retaining structures	: 250mm
(ii) Roof slabs for liquid retaining structures (other than flat slabs)	: 150mm
(iii) Bottom slabs for liquid retaining structures	: 200mm
(iv) Floor slabs including roof slabs, walkways, Canopy slabs	: 100mm
(v) Walls of cables/ pipe trenches, underground Pits etc.	: 125mm
(vi) Column footings	: 300mm
(vii) Parapets, chhajja	: 100mm
(viii) Precast trench cover	: 75mm

- In Mix design, the water cement ratio should not exceed 0.45. The exposer condition to be considered severe as chlorinated water is to be stored.
- The inside surface of the container of ESR and GSR shall be provided 20 mm thick water proof cement mortar plaster in CM 1:3 whereas outside surface of the GSR shall be sand faced In both admixture for waterproofing comply to BIS shall add in plastering works as per guidelines of design and engineer in charge and that of all surfaces of ESR i.e. container, shaft, etc. shall be exposed finished.

1.8 Materials in General

The term "materials" shall mean all materials, goods and articles of every kind whether RAW, processed or manufactured and equipment and plant of every kind to be supplied by the Contractor for incorporation in the Works.

Except as may be otherwise specified for particular parts of the works the provision of clauses in "Materials and Workmanship" shall apply to materials and workmanship for any part of the works.

All materials shall be new and of the kinds and qualities described in the Contract and shall be at least equal to approved samples.

As soon as practicable after receiving the order to commence the Works, the Contractor shall in form Addl. City Engineer of the names of the suppliers from whom he proposes to obtain any materials but he shall not place any order without the approval of Addl. City Engineer which may be withheld until samples have been submitted and satisfactorily tested. The Contractor shall thereafter keep Addl. City Engineer informed of orders for and delivery dates of all materials.

Materials shall be transported, handled and stored in such a manner as to prevent deterioration, damage or contamination failing which such damaged materials will be rejected and shall not be used on any part of the Works under this contract.

1.9 Samples and Tests of Materials

The Contractor shall submit samples of such materials as may be required by Addl. City Engineer and shall carry out the specified tests directed by Addl. City Engineer at the Site, at the supplier's premises or at a laboratory approved by Addl. City Engineer. Addl. City Engineer may appoint separate third party inspection for the material testing to ensure the quality of the work. The Contractor shall replace the defective material as an outcome of these tests.

Samples shall be submitted and tests carried out sufficiently early to enable further samples to be submitted and tested if required by Addl. City Engineer.

The Contractor shall give Addl. City Engineer seven days' notice in writing of the date on which any of the materials will be ready for testing or inspection at the supplier's premises or at a laboratory approved by Addl. City Engineer. Representative of Addl. City Engineer shall attend the test at the appointed place within seven Days of the said date on which the materials are expected to be ready for testing or inspection according to the Contractor, failing which the test may proceed in his absence unless instructed by Addl. City Engineer to carry out such a test on a mutually agreed date in his presence. The Contractor shall in any case submit to Addl. City Engineer's Representative within seven days of every test such number of certified copies (minimum six) of the test results as Addl. City Engineer may require.

Approval by Addl. City Engineer as to the placing of orders for materials or as to samples or tests shall not prejudice any of Addl. City Engineer's powers under the Contract.

The provisions of this clause shall also apply fully to materials supplied under any nominated sub-contract.

1.10 Standards

Materials and workmanship shall comply with the relevant Indian Standards (with amendments) current on the date of submission of the tender. All the governing items, materials, goods and equipments shall bear ISO-9001-2000 certification.

Where the relevant standard provides for the furnishing of a certificate to Addl. City Engineer, at his request, stating that the materials supplied comply in all respects with the standard, the Contractor shall obtain the certificate and forward it to Addl. City Engineer.

The specifications, standards and codes listed below are considered to be part of this Bid specification. All standards, specifications, codes of practices referred to herein shall be the latest editions including all applicable official amendments and revisions.

In case of discrepancy between the Bid Specification and the Standards referred to herein, the Bid Specification shall govern.

a) Materials

IS : 383	Specification for coarse and fine aggregates from natural sources for concrete
IS : 428	Specification for distemper, oil emulsion, colour as required
IS : 432	Specification for mild steel and medium tensile steel bars and hard drawn steel wire for concrete reinforcement (Parts 1 & 2)
IS : 455	Specification for Portland slag cement
IS : 458	Specification for precast concrete pipes(with and without reinforcement)
IS : 650	Specification for standard sand for testing of cement
IS : 651	Specification for salt glazed stoneware pipes and fittings
IS : 777	Specification for glazed earthenware tiles
IS : 808	Specification for dimensions for hot rolled steel column, channel and angle sections
IS : 814	Specification for covered electrodes for manual metal arc welding of Carbon and Carbon Manganese steel
IS : 1003	Specification for timber paneled and glazed shutters (Parts 1 & 2)
IS : 1038	Specification for steel doors, windows and ventilators
IS : 1077	Specification for common burnt clay building bricks
IS : 1398	Specification for packing paper,water proof, bitumen laminated
IS : 1489	Specification for Portland pozzolana cement (Parts 1&2)
IS : 1566	Specification for hard drawn steel wire fabric for concrete reinforcement
IS : 1580	Specification for bituminous compounds for water proofing and caulking purposes
IS : 1786	Specification for high strength deformed steel bars and wires for concrete reinforcement
IS : 1852	Specification for rolling and cutting tolerances for hot rolled steel products
IS : 1948	Specification for aluminium doors, windows and ventilators
IS : 1977	Specification for structural steel (ordinary quality)
IS : 2062	Specification for steel for general structural purposes
IS : 2185	Specification for concrete masonry units (Parts 1 & 2)
IS : 2202	Specification for wooden flush door shutters (Parts 1 & 2)
IS : 2645	Specification for integral cement water proofing compounds
IS : 2750	Specification for steel scaffoldings

IS : 2835	Specification for flat transparent sheet glass
IS : 3384	Specification for bitumen primer for use in waterproofing and damp roofing
IS : 3502	Specification for steel chequered plates
IS : 4021	Specification for timber door, window and ventilator frames
IS : 4350	Specification for concrete porous pipes for under drainage
IS : 4351	Specification for steel door frames
IS : 4990	Specification for plywood for concrete shuttering work
IS : 8112	Specification for 43 grade ordinary Portland cement
IS : 9862	Ready mixed paint, brushing, bituminous, black, lead free, acid, alkali, water and chlorine resisting
IS : 10262	Recommended guidelines for concrete mix design
IS : 12269	Specification for 53 grade ordinary Portland cement
IS : 12330	Specification for sulphate resisting Portland cement
IS : 12709	Glass fibre reinforced plastics (GRP) pipes, joints and fittings for use for potable water supply

b) Tests

- IS : 516 Method of test for strength of concrete
- IS : 1182 Recommended practice for radiographic examination of fusion welded butt joints in steel plates
- IS : 1199 Methods of sampling and analysis of concrete
- IS : 2386 Methods of test for aggregates for concrete (Parts 1 to 8)
- IS : 2720 Methods of test for soils (Parts 1 to 39)
- IS : 3025 Methods for sampling and test (physical and chemical) for water and wastewater (Parts 1 to 44)
- IS : 3495 Method of test for burnt clay building bricks (Parts 1 to 4)
- IS : 3613 Acceptance tests for wire flux combination for submerged arc welding
- IS : 4020 Methods of tests for wooden flush doors Type tests
- IS : 4031 Methods of physical tests for hydraulic cement (Parts 1 to 15)
- IS : 5807 Method of test for clear finishes for wooden furniture (Parts 1 to 6)
- IS : 7318 Approval tests for welders when welding procedure approval is not required (Parts 1 and 2)

C) Code of Practice

IS : 456	Code of practice for plain and reinforced concrete
IS : 783	Code of practice for laying of concrete pipes
IS : 800	Code of practice for general construction in steel
IS : 806	Code of practice for use of steel tubes in general building construction
IS : 816	Code of practice for use of metal arc welding for general construction in mild steel
IS : 817	Code of practice for training and testing of metal arc welders
IS : 875	Code of practice for design loads (other than earthquake) for building structures (Parts 1 to 5)
IS : 1081	Code of practice for fixing and glazing of metal (steel and aluminum) doors, windows and ventilators
IS : 1172	Code of practice for basic requirements for Water supply, drainage and sanitation
IS : 1477	Code of practice for painting of ferrous metals in buildings (Parts 1 & 2)
IS : 1597	Code of practice for construction of stone masonry (Parts 1 & 2)
IS : 1742	Code of practice for building drainage
IS : 1893	Criteria for earthquake resistant design of structures
IS : 2065	Code of practice for water supply in buildings
IS : 2212	Code of practice for brickwork
IS : 2338	Code of practice for finishing of wood and wood based materials (Parts 1 & 2)
IS : 2394	Code of practice for application of lime plaster finish
IS : 2395	Code of practice for painting, concrete, masonry and plaster surfaces (Parts 1 & 2)
IS : 2470	Code of practice for installation of septic tanks (Parts 1 & 2)
IS : 2502	Code of practice for bending and fixing of bars for concrete reinforcement
IS : 2571	Code of practice for laying in situ cement concrete flooring
IS : 2595	Code of practice for radiographic testing
IS : 2751	Recommended practice for welding of mild steel plain and deformed bars for reinforced construction
IS : 2974	Code of practice for design and construction of machine foundations (Parts 1 to 4)
IS : 3114	Code of practice for laying of Cast Iron pipes
IS : 3370	Code of practice for concrete structures for the storage of liquids (Parts 1 to 4)
IS : 3414	Code of practice for design and installation of joints in buildings
IS : 3558	Code of practice for use of immersion vibrators for consolidating concrete
IS : 3658	Code of practice for liquid penetrant flaw detection
IS : 3935	Code of practice for composite construction
IS : 4000	Code of practice for High strength bolts in steel

	structures
IS : 4014	Code of practice for steel tubular scaffolding (Parts 1 & 2)
IS : 4111	Code of practice for ancillary structures in sewerage system (Parts 1 to 4)
IS : 13920	Code of practice for laying of glazed stoneware pipes
IS: 4326	Code of practice for Earthquake Resistant Design and Construction of Buildings
IS : 4353	Recommendations for submerged arc welding of mild steel and low alloy steels
IS : 5329	Code of practice for sanitary pipe work above ground for buildings
IS : 5334	Code of practice for magnetic particle flaw detection of welds
IS : 5822	Code of practice for laying of welded steel pipes for water supply
IS : 7215	Tolerances for fabrication of steel structures
IS : 9595	Recommendations for metal arc welding of carbon and carbon manganese steels
IS : 10005	SI units and recommendations for the use of their multiples and of certain other units

d) Construction safety

IS: 3696	Safety code for scaffolds and ladder (Parts 1 & 2)
IS : 3764	Safety code for Excavation work
IS : 7205	Safety code for erection of structural steel work

1.10.1 Orientation

The works shall be laid out within the confines of the Site in order to interface to the existing infrastructure of roadways and inlet and outlet pipe work. Underground services requiring to be relocated in order to accommodate the proposed site layout shall, with the approval of Addl. City Engineer, be relocated by the Contractor.

1.11 Valve Chambers

- a) All valve chambers are to be of an adequate size to facilitate maintenance and operation. The base slab of valve chambers shall slope towards a sump pit from which water can be pumped to keep the chamber dry. All valve chambers shall be constructed in M15 grade reinforced concrete. Chambers shall have removable cast iron / reinforced concrete covers, as appropriate, approach ladders and valve supports.

1.12 Landscaping

The pump house plot site shall be landscaped once the Works are substantially complete. The landscaping scheme shall be submitted and got approved from Addl. City Engineer prior to start of actual work.

Landscaping shall include planting of suitable trees and development of grassed areas. Landscaping in general shall meet ecological and environmental conditions of the site. Road widths shall determine the size of the tree height and spread to be selected for planting. Trees suitable for local conditions shall be selected. Medicinal and fruit trees shall be avoided.

Ready Mix Concrete:

Form Work

The form work shall conform to the shape lines and dimension as shown on the plans and be so constructed as to remain sufficiently rigid during the placing and compacting of the concrete. Adequate arrangements shall be made by the contractor to safe-guard against any settlement of the form work during the course of concreting and after concreting. The form work of shuttering, centering, scaffolding bracing etc. shall be as per design.

Cleaning & Treatment of forms :- All rubbish, particularly chippings shaving and saw dust shall be removed from the interior of the Form before the concrete is placed and the formwork in contact with concrete shall be cleaned and thoroughly Welled or treated. The surface shall be then coated with soap solution applied before concreting is done. Soap solution for the purpose shall be prepared by dissolving yellow soap in water to get consistency of Paint. Alternatively a coat of raw linseed oil or form oil of approved manufacture may be applied in' case steel Shuttering is used. Soap solution or raw linseed oil shall be applied after thoroughly cleaning the surface. Care shall be taken that the coating does not get on construction joint surface and reinforcement bars.

Stripping time:- 1In normal circumstances and where ordinary cement is used forms may be struck after expiry of following periods. :

In normal circumstances and where ordinary cement is used forms may be struck after expiry of following periods. :

- (a) Sides of walls columns and vertical faces of beam-24 to 48 hours.
- (b) Beams of ties; (Props left under)-7days.
- (c) Removal of props slabs.
 - (i) Slabs spanning upto 4.5m----- 7days.
 - (ii) Spanning over 4.5m ----- 14days.

- | | |
|--|---------|
| (d) Removal of props to beams and Arches | |
| (i) Spanning upto 6m----- | 14days, |
| (ii) Spanning over 6m----- | 21days |

Procedure when removing the form work: -

All form work shall be removed without such shock or vibrations as would damage the reinforced concrete surface. Before the softies form work and struts are removed, the Softies and the concrete surface shall be exposed' where necessary in order to ascertain that the concrete has sufficiently hardened.

Centering:

The centering to be provided shall be got approved. It shall be sufficiently strong to ensure absolute safety of the form work and concrete work before, during and after pouring concrete. Watch should be kept to see that behavior of centering and form work is satisfactory during concreting. Erection should also be such that it would allow removal of forms in proper sequence without damaging either the concrete or the forms to be removed.

The props of centering shall be provided on firm foundation or base of sufficient strength to carry the loads without any settlement. The centering and form work shall be inspected and approved by the Engineer-in-charge before Concreting. But this will not relieve the contractor of his responsibility for strength, adequacy and safety of Form work and centering. If there is a failure of form work or centering, contractor shall be responsible for the Damages to the work, injury to life and damage to property.

Scaffolding:

scaffolding, hoisting arrangements and ladders etc. required for the facilitating of concreting shall be provided and removed on completion work by contractor at his own expense. The scaffolding, hoisting Arrangements and ladders etc. shall be strong enough to withstand all live, dead and impact loads expected.

3.7 Concrete

3.7.1 General

In concrete grade M15, M20, M25, M30 etc. the number represents the specified characteristic compressive strength of 150 mm cube at 28 days, expressed in N/sq. mm as per IS: 456. Concrete in the works shall be "DESIGN MIX CONCRETE "or "NOMINAL MIX CONCRETE". All concrete works of grade M5, M7.5 and M10 shall be NOMINAL MIX CONCRETE whereas all other grades, M15 and above, shall be DESIGN MIX CONCRETE.

3.7.2 Design Mix Concrete

(a) Mix Design & Testing

For design mix concrete, the mix shall be designed according to IS: 10262 and SP:23 to provide the grade of concrete having the required workability and characteristic strength not less than

appropriate values given in IS:456. The design mix shall in addition to such that it is cohesive and does not segregate and should result in dense and durable concrete and also capable of giving the finish as specified. For water retaining structure, the mix shall also result in water tight concrete. The Contractor shall exercise great care while designing the concrete mix and executing the workers to achieve the desired result.

Unless otherwise specially mentioned, the minimum cement content and maximum water cement ratio for Design Mix Concrete shall be as

Given below:

Grade of Concrete	Minimum cement Content in Kg/Cum of	Maximum
M20	360	0.55
M25	380	0.50
M30	400	0.45

The minimum cement content stipulated above shall be adopted irrespective of whether the Contractor achieves the desired strength with less quantity of cement. The CONTRACTOR'S quoted rates for concrete shall provide for the above eventuality and nothing extra shall be come payable to the CONTRACTOR in this account. Even in the case where the quality of cement required is higher than that specified above to achieve desired strength based on an approved mix design, nothing extra shall become payable to the CONTRACTOR.

It shall be the Contractor's sole responsible to carry out the mix designs at his own cost. He shall furnish to the Engineer-in-charge at least 30 days before concreting operations, a statement of proportions proposed to be used for the various concrete mixes ascertained on 150 mm cubes as per IS:516 shall comply with the requirements of IS:456.

Grade of Concrete	Minimum compressive strength N/Sq.mm	Specified characteristic compressive
M15	10.0	15.0
M20	13.5	20.0
M25	17.0	25.0
M30	20.0	30.0
M35	23.5	35.0
M40	27.0	40.0

A range of slump which shall generally be used for various types of construction unless otherwise instructed by the Engineer-in-charge is given below:

Structure/Member	Slump in	
	Maximum	Minimum
Reinforced foundation walls and footings	75	25
Plain footings , caissons and sub structure walls	100	25
Slabs, Beam sand reinforced walls Pump & miscellaneous	75	25
Foundations	100	25
Building Column	50	25
Pavements	50	25
Heavy mass construction	50	25

(b) Batching & Mixing of Concrete

Proportions of aggregates and cement, as decided by the concrete mix design, shall be by weight. These proportions shall be maintained during subsequent concrete batching by means of weigh batchers capable of controlling the weights within one percent of the desired value. Amount of water added shall be such as to produce dense concrete of required consistency, specified strength and satisfactory workability and shall be so adjusted to account for moisture content in the aggregates. Water-cement ratio specified

for use by the Engineer-in-charge shall be maintained. Each time the work stops, the mixer shall be cleaned out, and while recommencing, the first batch shall have 10% additional cement to allow for sticking in the drum.

Arrangement should be made by the Contractor to have the cubes tested in an approved laboratory or in field with prior consent of the Engineer-in-charge. Sampling and testing of strength and workability of concrete shall be as per IS: 1199, IS: 516 and IS: 3370.

(c) Ready Mix Concrete

Minimum cement consumption shall be as specified in tender document. However, necessary computer printout for consumption of all materials and mixtures if permitted shall be made available as and when required in any frequencies as directed by Engineer-in-charge.

Necessary slump requirements at the pouring places shall be made available with ready mix concrete.

Concrete mix shall be design for 33% higher strength than the grade of concrete specified. The proportions for ingredients chosen shall be such that concrete has adequate workability for condition prevailing on the work in question and can be properly compacted with the means available. Use of cementitious material like Fly ash etc. shall not be permissible.

Except where it can be shown to the satisfaction of the Engineer-in-charge that a supply of properly graded aggregate of uniform quality can be maintained till the

completion of work, grading of aggregate should be strictly controlled. The different sizes shall be stocked in separate stock piles. Required quality of material shall be stock-piled several hours, preferably a day, before use. Grading of coarse and fine aggregate shall be checked as frequently as possible, frequency for a given job being determined by the Engineer-in-charge to ensure that the suppliers are maintaining the uniform grading as approved for samples used in the design mix.

The quantity of both cement and aggregate shall be determined by weight. Water shall either be measured by volume in calibrated tanks or weighed. All measuring equipment shall be maintained in a clean and serviceable condition. Their accuracy shall be periodically checked.

It is most important to keep the specified water – cement ratio constants and its correct value. To this end, the moisture content in both fine and coarse aggregates shall be determined by the Engineer-in-charge according to the weather conditions. The amount of mixing water shall then be adjusted to compensate for variations in the moisture content. For the determination of moisture content in the aggregates, IS: 2386 (Part-III) shall be referred to. Suitable adjustments shall also be made in the weights of aggregates to allow for the variation in weights of aggregates due to variation in their moisture content.

The special Conditions/Specification regarding Ready Mix Concrete are as follows. The details like locations, capacity, experience, delivery schedule etc. of the Ready Mix Concrete agency shall be submitted by the successful tenderer for prior approval of the undersigned.

The Ready Mix Concrete shall be conforming to IS : 4926 with its latest amendments.

All the responsibility of Ready Mix Concrete i.e. procurement for all materials, operation of plant and machinery, transit mixers, pumping machineries relevant piping etc. shall be on the account of the contractor.

The Rajkot Municipal Corporation shall not be held responsible for any delay / damage/loss due to deployment of Ready Mix Concrete for this project.

The octroi or any other type of tax / cess for the Ready Mix Concrete shall have to be borne by the contractor as per prevailing rates. Ready Mix Concrete process shall be fully automatic and computerized.

When a transit mixer is used for transportation of concrete, no extra water should be added to the concrete from elsewhere

after initial introduction of mixing water from the batch, except when on arrival at the site of the work, the slump of the concrete is less than that specified: such additional water to bring the mixer under such pressure and direction of flow that requirements for uniformity are met.

Record sand certificates:

The contractor shall keep from the manufacture batch records of the quantities by mass of all mixing and of the result so fall tests. If required by the Rajkot Municipal Corporation, the contractor shall furnish certificates, at agreed intervals, giving this information.

The contractor shall supply the following information for guidance of the manufacturer :

- The type of cement to be used
- Details Specification of aggregates to be used.
- Type of admixture to be used. If specified.
- Min. acceptable strength
- Slump of concrete or compaction factor
- Age sat which the test cubes or beams are to be tested and the frequency and number of test to be made.
- Any other requirement.

Tolerance : Unless otherwise agreed to between the Rajkot Municipal Corporation (RMC) and the contractor, the concrete shall be deemed to comply with the requirements of this, if these results of testes where applicable lie within the tolerance specified below.

Consistency of workability : The slump average of two tests shall not differ from the specified value by + 10 mm for a specified slump of 75 mm. The compacting fact or average of two tests shall be within+0.03 of the value specified. If any other method of determining consistency to be used a suitable tolerance shall be agreed to be between the purchaser and the manufacture. The tests for consistency or workability shall be complete within 15 minutes of the time of receipt of the ready mix concrete at the site.

Aggregate : When tested in accordance with IS 2386 (Part-I) 1963, the quantity of aggregate larger than the max size specified by the purchaser shall not exceed 5% of the qty. of coarse aggregate and all such pass sieve of next higher size.

3.7.3 Nominal Mix concrete (DELETED)

(a) Mix design and testing

Mix design and preliminary test are not necessary for Nominal Mix concrete. However works test shall be carried out as per IS : 456. Proportions for Nominal Mix Concrete and w/c ratio may be adopted as per Table 3 of IS:

456. However it will be the Contractor's role responsibility to adopt appropriate nominal mix proportions to yield the specified strength.

(b) Batching & Mixing of Concrete

Based on the adopted nominal mixes, aggregates shall be measured by volume. However cement shall be by weight only.

3.8 Formwork

formwork shall be all inclusive and shall consist of but not be limited to shores, bracing's sides of footing , walls, beams and columns, bottom of slabs etc. including ties, anchors, hangers, inserts, false work, wedges etc.

The design and engineering of the form work as well its construction shall be the responsibility of the Contractor. However, if so desired by the Engineer-in-charge the DRAWING and calculating for the design of the formwork shall be submitted to the Engineer-in-charge for approval.

Form work shall be designed to fulfill the following requirements:

- (a) Sufficiently rigid and tight to prevent loss of grout or mortar from the concrete at all stages and appropriate to the method of placing and compacting.
- (b) Made of suitable materials.
- (c) Capable of providing concrete of the correct shape and surface finish within the specified tolerance limits.
- (d) Capable of withstanding without deflection the worst combination of self weight, reinforcement and concrete weight, all loads and dynamics effect arising from construction and compacting activities, wind and weather forces.
- (e) Capable of easy striking out without shocks, disturbance or damages to the concrete.
- (f) Soffit forms capable of imparting a camber if required.
- (g) Soffit forms and supports capable of being left in position if required.

- (h) Capable of being cleaner and/or coated if necessary immediately prior to casting the concrete; design temporary openings where necessary for these purposes and to facilitate the preparation of construction joints.

The form work may be of timber, plywood, steel, plastic or concrete depending upon the approval of the Engineer-in-charge. Timber of formwork shall be well seasoned, free sap, shakes, loose knots, worm holes, warps and other surface defects. Joints between formwork and formwork and between formwork and structures shall be sufficiently tight to prevent loss of slurry from concrete, using seals if necessary.

The faces of formwork coming in contact with concrete shall be cleaned and two coats of approved mould oil applied before fixing reinforcement. All rubbish, particularly chippings, sailings, sawdust, wire pieces etc. shall be removed from the interior of the forms before the concrete is placed. Where directed, cleaning of forms shall be done by blasting with a jet of compressed air at no extra cost.

Forms intended for reuse shall be treated with care. Forms that have deteriorated shall not be used. Before reuse, all forms shall be thoroughly scraped, cleaned, nails removed, holes suitably plugged, joints repaired and warped lumber replaced to the satisfaction of the Engineer-in-charge. The Contractor shall equip himself with enough shuttering to allow for wastage so as to complete the job in time.

Permanent formwork shall be checked for its durability and compatibility with adjoining concrete before it is used in the structure. It shall be properly anchored to the concrete.

Wireties passing through beams, columns and walls shall not be allowed. In their place bolts passing through sleeves shall be used. Formwork spacers left in situ shall not impair the desired appearance or durability of the structure by causing spalling, rust staining or allowing the passage of moisture.

For liquid retaining structures, sleeves shall not be provided for through bolts nor shall through bolts be removed if provided. The bolts, in the latter case, shall be cut at 25 mm depth from the surface and the hole made good by cement mortar of the same proportion as the concrete just after striking the formwork.

Where specified all corner and angles exposed in the finished structure shall have chamfers or fillets of 20 mm X 20 mm size.

Form for substructure may be omitted when, in the opinion of the Engineer-in-charge, the open excavation is firm enough (in hard non-porous soils) to act as a form, such excavation shall be larger, as approved by the Engineer-in-charge that required as per DRAWING to compensate for irregularities in excavation.

The Contractor shall provide adequate props carried down to a firm bearing without overloading any of the structure.

The shuttering for beams and slabs shall be so erected that the side shuttering of beams can be removed without disturbing the bottom shuttering

.If the shuttering for a column is erected for the full height of the column, one side shall be build up in sections as placing of concrete proceeds or windows left for placing concrete from the side to limit the drop of concrete to 1.0 m or as approved by the Engineer-in-charge. The Contractor shall temporarily and securely fix items to be cast (embodiment's/inserts) in a manner that will not hinder the striking of forms or permit loss of grout.

Formwork showing excessive distortion, during any stage of construction, shall be repositioned and strengthened. Placed concrete affected by faulty formwork, shall be entirely removed and formwork corrected prior to placement of new concrete at Contractor's cost.

The striking time for formwork shall be determined based on the following requirement:

- a) Development of adequate concrete strength;
- b) Permissible deflection at time of striking formwork;
- c) Curing procedure employed-its efficiency and effectiveness;
- d) Subsequent surface treatment to be done;
- e) Prevention of thermal cracking at re-entrant angles;
- f) Ambient temperatures;
- g) Aggressiveness of the environment (unless immediate adequate steps are taken to prevent damage to the concrete).

Under normal circumstances (generally where temperatures are above 20⁰ C) forms may be struck after expiry of the time period given in IS: 456 unless approved otherwise by Engineer-in-charge, it is the Contractor's responsibility to ensure that forms are not struck until the concrete has developed sufficient strength to support itself, does not undergo excessive deformation and resist surface damage and any stresses arising during the construction period.

3.9 Reinforcement

Workmanship

Reinforcement bars supplied bent or in coils shall be straightened cold without damage. No bending shall be done when ambient temperature is below 5⁰C. Local warming may be permitted if steel is kept below 5⁰C.

All bars shall be accurately bent gradually and according to the size and shapes shown on the DRAWING schedules or as directed by Engineer-in-charge.

Re-bending or straightening incorrectly bent bars shall not be done without the approval of the Engineer-In-Charge.

Reinforcement shall be accurately fixed and maintained firmly in the correct position by the use of blocks, spacers, chairs, binding wire etc. to prevent displacement during placing and compaction of concrete. The tied in place reinforcement shall be approved by the Engineer-in-charge prior to concrete placement. Spacers shall be of such materials and design as will be durable, not lead to corrosion of the reinforcement and not cause spalling of the concrete cover.

Binding wire shall be 16 gauges soft annealed wire. End of the binding wire shall be bent away from the concrete surface and in no case encroach into the concrete cover.

Substitution of reinforcement; laps/splices not shown on Drawing shall be subject to Engineer-in-charge's approval.

3.10 Tolerances

Tolerance for formwork and concrete dimensions shall be as per IS: 456 unless specified otherwise.

Tolerances specified for horizontal or vertical building lines or footings shall not be construed to permit encroachment beyond the legal boundaries.

The formwork shall be designed and constructed to the shapes, lines and dimensions shown on the Drawings within the tolerances given below:

(a)	Deviation from specified dimensions of cross section of columns and beams	-6mm
(b)	Deviations from dimensions of footings (tolerances apply to concrete dimensions only, not to positioning of vertical reinforcing steel or dowels)	+12mm
1.	Dimension in plan	-12 +50mm
2.	Eccentricity	0.02 times the width of the footing in the direction of deviation but not more than
3.	Thickness	+0.05 times the specified thickness

3.11 Preparation Prior to Concrete Placement

Before concrete is actually placed in position, the inside of the formwork shall be cleaned and mould oil applied, insert and reinforcement shall be correctly positioned and securely held, necessary openings, pockets, etc. provide.

All arrangements formwork, equipment and proposed procedure, shall be approved by the Engineer-in-charge, Contractor shall maintain separate Pour card for each pour as per the format enclosed.

3.12 Transporting, Placing and Compacting Concrete

Concrete shall be transported from the mixing plant to the formwork with minimum time lapse by methods that shall maintain the required workability and will prevent segregation, loss of any ingredients or ingress of foreign matter or water.

In all cases concrete shall be deposited as nearly as practicable directly in its final position. To avoid segregation, concrete shall not be re handled or cause to flow. For locations where direct placement is not possible and in narrow forms the Contractor shall provide suitable drops and "Elephant Trunks". Concrete shall not be dropped from a height of more than 1.0 m

Concrete shall not be placed in flowing water. Underwater, concrete shall be placed in position by termite or by pipeline from the mixer and shall never be allowed to fall freely through the water.

Concreting underwater:

When it is necessary to deposit concrete under water, the methods, equipments, and materials of the mix to be used shall be got approved from the Engineer-in-charge before any work is started. Such concreting be considered as controlled concrete i.e. design mix.

Concrete shall not be placed under temperature below 50 degree centigrade. The temperature of concrete, when deposited, shall be however not less than 50 centigrade nor more than 40 degree centigrade.

Concrete to be placed under water shall contain ten percent more cement than that required for the same mix placed in the dry.

The slump shall not be less than 100 mm nor more than 180 mm. The slump shall be tested as per I. S. 516.

Coffer-dams or forms shall be watertight to ensures till water conditions if practicable and in any case to reduce the flow of water to less than 3 meters per minute through the space into which concrete is to be deposited. The forms in still water shall be sufficiently tight to prevent loss of mortar through the joints in

the walls. Pumping shall not be done while concrete is being placed, or until 24 hours thereafter.

Concrete shall continue to be deposited until it has been brought to the required height. The top surface shall always be kept as wet as far as possible and formation of seems avoided. For concrete any one of the following methods may be used.

(a) Tremie:

When concrete is to be deposited under water by means of tremie, the top section of the tremie shall be a hopper large enough to hold one full batch mixer the entire contents of the transporting bucket. The tremie pipe shall not be less than 200 mm dia. and also shall be large enough to allow a free flow of concrete and strong enough to with stand the external pressure of water in which it is suspended, even if a partial vacuum develops inside the pipe. Preferably, flanged steel pipe of adequate strength for the job shall be used. A separate lifting device shall be provided for each tremie pipe with hopper at the upper end. Unless the lower end of the pipe is equipped with an approved automatic check valve, the upper end of the pipe shall be plugged with a wedging by use of gunny sacks or other approved material before delivering the concrete to the tremie pipe through the hopper, so that when the concrete is forced down from the hopper to the pipe, it will force the plug (and along with it any water in the pipe) down the pipe and out of the bottom end. Thus establishing a continuous stream of concrete. It will be necessary, to raise slowly the tremie in the order to allow a uniform flow of concrete, but it shall not be emptied so that water enters above the concrete in the pipe.

At all times after the placing of concrete is started and until all the requirement quantity has been placed, the lower end of the tremie pipe shall be kept below the top surface of the plastic instead of flowing out over the surface, and thus avoid formation of layers of laitance. If the charge in the tremie is lost while depositing, the tremie shall be raised above the concrete surface, and unless sealed by a check valve it shall be re-plugged at the top end, as at the beginning before refilling for depositing further concrete.

(b) Drop Bottom Bucket :

The top of the bucket shall be closed. The bottom doors shall move freely downward and outward when tripped. The bucket shall be filled completely and lowered slowly to avoid backwash. It shall not be dumped until it rests on the surface upon which the concrete is to be deposited and when discharged shall be withdrawn slowly until well above the concrete.

To minimize the formation of laitance, great care shall be exercised to disturb the concrete as far as possible while it is being deposited.

While placing concrete the Contractor shall proceed as specified below and also ensure the following.

- a) Continuously between construction joints and pre-determined abutments.
- b) Without disturbance to forms or reinforcement.
- c) Without disturbance to pipes, ducts, fixing and the like to be cast in: ensure that such items are securely fixed. Ensure that concrete cannot enter open ends of pipes and conduits etc.
- d) Without dropping in a manner that could cause segregation or shock.
- e) In deep pours only when the concrete and formwork designed for this purpose and by using suitable chutes or pipes.
- f) Do not place if the workability is such that full compaction cannot be achieved.
- g) Without disturbing the unsupported sides of excavations; prevent contamination of concrete with earth. Provide sheeting if necessary. In supported excavations, withdraw the lining progressively as concrete is placed.
- h) If placed directly on to hard core or any other porous material, dampen the surface to reduce loss of water from the concrete.;
- i) Ensure that there is no damage or displacement to sheet membranes.
- j) Record the time and location of placing structural concrete.

Concrete shall normally be compacted in its final position within thirty minutes of leaving the mixer. Concrete shall be compacted during placing with approved vibrating equipment without causing segregation until it forms a solid mass free from voids thoroughly worked around reinforcement and embedded fixtures and into all corners of the formwork. Immersion vibrators shall be inserted vertically at points not more than 450 mm apart and withdrawn slowly till air bubbles cease to come to the surface, leaving no voids. When placing concrete in layers advancing horizontally, care shall be taken to ensure adequate vibration blending and melting of the concrete between successive layers. Vibrators shall not be allowed to come in contact with reinforcement, formwork and finished surfaces after start of initial set. Over-vibration shall be avoided.

Concrete may be conveyed and placed by mechanically operated equipment after getting the complete procedure approved by the Engineer-in-charge. The slump shall be held to the minimum necessary for conveying concrete by this method. When concrete is to be pumped, the concrete mix shall be specially designed to suit pumping. Care shall be taken to avoid stoppages in work once pumping has started.

Except when placing with slip forms, each placement of concrete in multiple lift work shall be allowed to set for at least 24 hours

after the final set of concrete before the start of subsequent placement. Placing shall stop when concrete reaches the top of the opening in walls or bottom surface of slab, in slab and beam construction, and it shall be resumed before concrete takes initial set but not until it has had to settle as approved by the Engineer-in-charge. Concrete shall be protected against damage until final acceptance.

3.13 Mass Concrete Works

Sequence of pouring for mass concrete works shall be as approved by the Engineer-in-charge. The Contractor shall exercise great care to prevent shrinkage cracks and shall monitor the temperature of the placed concrete if directed.

3.14 Curing

Curing and protection shall start immediately after the compaction of the concrete to protect it from:

- a) Premature drying out, particularly by solar radiation and wind;
- b) Leaching out by rain and flowing water;
- c) Rapid cooling during the first few days after placing;
- d) High internal thermal gradients;
- e) Low temperature or frost;
- f) Vibration and impact which may disrupt the concrete and interfere with its bond to the reinforcement.

All concrete, unless approved otherwise by the Engineer-in-charge shall be cured by use of continuous sprays or pounded water or continuously

saturated coverings of sacking, canvas, hessian or other absorbent material for the period of complete hydration with a minimum of 7 days. The quality of curing water shall be the same as that used for mixing.

Where a curing membrane is approved to be used by the Engineer-in-charge, the same shall be of a non-wax be sand shall not impair the concrete finish in any matter. The curing component to be used and shall be applied with spraying equipment capable of a smooth, even textured coat.

Curing may also be done by covering the surface with an impermeable material such as polyethylene, which shall be sealed and fastened.

3.15 Construction Joints and Keys

Construction joints will be shown on the DRAWING or as approved by the Engineer-in-charge. Concrete shall be placed without interruption until completion of work between construction joints. If stopping of concreting becomes unavoidable anywhere, a properly formed, construction joints shall be made with the approval of the Engineer-in-charge.

Dowels for concrete work, not likely to be taken up in the near future, shall be coated with cement slurry and encased in lean concrete as indicated on the DRAWINGS or as approved by the Engineer-in-charge.

Before resuming concreting on a surface which has not fully hardened, all laitance and loose stone shall be thoroughly removed by wire brushing/hacking and surface washed with high pressure water jet and treated with thin layer of cement slurry for vertical joints and horizontal layers.

When concreting is to be resumed on a surface which has not fully hardened, all laitance shall be removed by wire brushing the surface wetted, free water removed and a coat of cement slurry applied. On this, a layer of concrete not exceeding 150 mm thickness shall be placed and well rammed against the old work. Thereafter work shall proceed in the normal way.

3.16 Foundation Bedding

All earth surfaces upon which or against which concrete is to be placed, shall be well compacted and free from standing water, mud or debris. Soft or spongy areas shall be cleaned out and back filled with either soil-cement mixture, lean concrete or clean sand compacted as approved by the Engineer-in-charge. The surfaces of absorptive soils shall be moistened.

Concrete shall not be deposited on large sloping rock surfaces. The rock shall be cut to form rough steps or benches by picking, barring or wedging. The rock surface shall be kept wet for 2 to 4 hours before concreting.

3.17 Finishes

3.17.1 General

The formwork for concrete works shall be such as to give the finish as specified. The Contractor shall make good any unavoidable defects as approved consistent with the type of concrete and finish specified. Defects due to bad workmanship (e.g. damaged or misaligned forms, defectives or poorly compacted concrete) will not be accepted. The Contractor shall construct the formwork using the correct materials and meet the requirements of the design and to produce finished concrete to required dimension, plumbs, planes and finishes.

3.17.2 Surface Finish Type F1

The main requirement is that of dense, well compacted concrete. No treatment is required except repair of defective areas filling all form tie holes and cleaning up of loose or adhering debris. For surface below grade which will receive waterproofing treatment the concrete shall be free of surface irregularities which would interfere with proper and effective application of waterproofing material specified for use.

3.17.3 Surface Finish Type F2

The appearance shall be that of a smooth dense, well-compacted concrete showing the slight marks of well fitted shuttering joints. The Contractor shall make good any blemishes.

3.17.4 Surface Finish Type F3

This finish shall give an appearance of smooth, dense, well-compacted concrete with no shutter marks, stain free and with no discoloration, blemishes, arises, airholes etc. only line dor coated plywood with very tight joints shall be used to achieve this finish. The panel size shall be uniform and as large as practicable. Any minor blemishes that might occur shall be made good by the Contractor.

3.17.5 Integral Cement Finish on Concrete Floor

In all cases where integral cement finish on a concrete floor has been specified, the top layer of concrete shall be screeded off to proper level and tamped with tamper having conical projections so that the aggregate shall be forced below the surface. The surface shall be finished with a wooden float and a trowel with pressure. The finish shall be continued till the concrete reaches its initial set. No cement or cement mortar finish shall be provided on the surface. Where specified, a floor hardener as approved by the Engineer-in-charge shall be supplied and used as recommended by the manufacturer.

3.18 Repair and Replacement of Unsatisfactory Concrete

Immediately after the shuttering is removed, all the defective areas such as honeycombed surfaces, rough patches and holes left by form bolts etc. shall be inspected by the Engineer-in-charge who may permit patching of the defective areas or reject the concrete work.

All through holes for shuttering shall be filled for full depth and neatly plugged flush with surface.

Rejected concrete shall be removed and replaced by the Contractor at no additional cost of the Owner.

For patching of defective areas all loose materials shall be removed and the surface shall be prepared as approved by the Engineer-in-charge.

Bonding between hardened and fresh concrete shall be done either by placing cement mortar or by applying epoxy. The decision of the Engineer-in-charge as to the method of repair to be adopted shall be final and binding on the Contractor. The surface shall be saturated with water for 24 hours before patching is done with 1:1 cement sand mortar. The use of epoxy for rebinding fresh concrete shall be carried out as approved by the Engineer-in-charge.

3.19 Vacuum dewatering of Slabs

Where specified floor slabs, either grade or suspended, shall be finished by vacuum dewatering including all operations such as poker vibration, surface vibration, vacuum processing, flatting and trowelling as per equipment manufacturers recommendation.

The equipment to be used shall be subject to the Engineer-in-charge.

3.20 Hot Weather Requirements

Concrete during hot weather shall be carried out as per IS: 7861(Part I).

Adequate provisions shall be made lower concrete temperatures which shall not exceed 40°C at the time of placement of fresh concrete.

Where directed by the Engineer-in-charge, the Contractor shall spray non- wax based curing compound on unformed concrete surface at no extra costs.

3.21 Cold weather Requirement

Concreting during cold weather shall be carried out as per IS: 7861(Part II).

The ambient temperature during placement and up to final set shall not fall below 5 deg.C. Approved anti freeze/accelerating additives shall be used where directed.

For major and large scale concreting works the temperature of concrete at times of mixing and placing, the thermal conductivity of the formwork and its insulation and stripped period shall be closely monitored.

3.22 Liquid Retaining Structures

The Contractor shall take special care for concrete for liquid retaining structures, underground structures and those others specifically called for to guarantee the finish and water tightness.

The minimum level of surface finish for liquid retaining structures shall be Type F2. All such structures shall be hydro-tested.

The Contractor shall make all arrangement for hydro-testing of structure, all arrangements for testing such as temporary bulk heads, pressure gauges, pumps, pipe lines etc.

The Contractor shall also make all temporary arrangements that may have to be made to ensure stability of the structures during construction.

Any leakage that may occur during the hydro-test or subsequently during the defects liability period or the period for which the structure is guaranteed shall be effectively stopped

either by cement/epoxy pressure grouting, guniting or such other methods as may be approved by the Engineer-in-charge. All such rectification shall be done by the CONTRACTOR to the entire satisfaction of the Engineer-in-charge at no extra cost to the OWNER.

3.23 Testing Concrete Structures for Leakage

Hydro-static test for water tightness shall be done at full storage level or soffit of cover slab, as may be directed by the Engineer-in-charge as described below:

In case of structures whose external faces are exposed, such as elevated tanks, the requirements of the test shall be deemed to be satisfied if the external forces show no sign of leakage or sweating and remain completely dry during the period of observation of seven days after allowing a seven day period for absorption after filling with water.

In the case of structures whose external faces are buried and are not accessible for inspection, such as underground tanks, the structures shall be filled with water and after the expiry of seven days after the filling; the level of the surface of the water shall be recorded. The level of water shall be recorded against subsequent intervals of 24hrs. over a period of seven days. Backfilling shall be withheld till the tanks are tested. The total drop in surface level over a period for seven days shall be taken as an indication of the water tightness of the structure. The Engineer-in-charge shall decide on the actual permissible nature of this drop in the surface level, taking into account whether the structures are open or closed and the corresponding effect it has on evaporation losses. Unless specified otherwise, a structure whose top is covered shall be deemed to be water tight if the total drop in the surface level over a period of seven days does not exceed 40 mm.

Each compartment/segment of the structure shall be tested individually and then all together.

For structures such as pipes, tunnels etc. The hydrostatic test shall be carried out by filling with water, after curing as specified, and subjecting to the specified test pressure for specified period. If during this period the loss of water does not exceed the equivalent of the specified rate, the structure shall be considered to have successfully passed the test.

3.24 Optional Tests

If the Engineer-in-charge feels that the materials i.e. cement, sand, coarse aggregates, reinforcement and water are not in accordance with the Specifications or if specified concrete strengths are not obtained, he may order tests to be carried out on these materials in laboratory, to be approved by the Engineer-in-charge as per relevant IS Codes. Contractor shall have to pay for these tests.

In the event of any work being suspected of faulty material or workmanship requiring is removal or if the works cubes do not give the stipulated strengths, the Engineer-in- charge reserves the right to order the Contractor to take out cores and conduct tests on them or do ultrasonic testing or load testing of structure ,etc. The Engineer-in- charge also reserves the right to ask the Contractor to dismantle and re-do such un acceptable work, at no cost to the Owner. Alternately Engineer-in-charge also reserves the right to ask the COTRACTOR to dismantle and re-do such unacceptable work at the cost of CONTRACTOR.

3.25 Grouting

3.25.1 Standard Grout

Grout shall be provided as specified on the DRAWINGS. The proportion of Standard grout shall be such as to produce a flow able mixture consistent with minimum water content and shrinkage. Surfaces to be grouted shall be thoroughly roughened and cleaned. All structural steel elements to be grouted shall be cleaned of oil, grease, dirt etc. The use of hot, strong caustic solution for this purpose will be permitted. Prior to grouting, the hardened concrete shall be saturated with water and just before grouting, water in all pockets shall be removed. Grouting once started shall be done quickly and continuously. Variation in grout mixes and procedures shall be permitted if approved by the Engineer-in-charge. The grout proportions shall be limited as follows:

Sr no	Use	Grout Thickness	Mix Proportions	W/C Ratio
a)	Fluid mix	Under 25mm	One part Portland Cement To one part sand	0.44
b)	General mix	25mm and over but less than 50 mm	One part Portland Cement to two part sand	0.53
c)	Stiff mix	50mm and over	One part Portland Cement to	0.53

3.25.2 Non-Shrink Grout

Non-shrink grout where required shall be provided instrict accordance with the manufacturer's instructions/specifications on the DRAWINGS.

General

Inspection

All materials, workmanship and finished construction shall be subject to continuous inspection and approval of Engineer-in-charge. Material rejected by Engineer-in- charge, shall be expressly removed from site and shall be replaced by Contractor immediately.

Clean-up

Upon the completion of concrete work, all forms, equipment, construction tools, protective coverings and any debris, scraps of wood, etc. resulting from the work shall be removed and the premises left clean.

Acceptance Criteria

Any concrete work shall satisfy the requirements given below individually and collectively for it to be acceptable.

- a) Properties of constituent material;
- b) Characteristic compressive strength;
- c) Specified mix proportions;
- d) Minimum cement content;
- e) Maximum free-water/cement ratio;
- f) Workability;
- g) Temperature of fresh concrete;
- h) Density of fully compacted concrete;
- i) Cover or embedded steel;
- j) Curing;
- k) Tolerances in dimension;
- l) Tolerance in levels;
- m) Durability;
- n) Surface finishes;
- o) Special requirements such as;
 - i) Water tightness
 - ii) Resistance to aggressive chemicals
 - iii) Resistance to freezing and thawing
 - iv) Very high strength
 - v) Improved fire resistance
 - vi) Wear resistance
 - vii) Resistance to early thermal cracking

The Engineer-in-charge decision as to the acceptability or otherwise of any concrete work shall be final and binding on the Contractor.

For work not accepted, the Engineer-in-charge may review and decide whether remedial measures are feasible so as to render the work acceptable. The Engineer-in-charge shall in that case direct the Contractor to undertake and execute the remedial measures.

These shall be expeditiously and effectively implemented by the Contractor. Nothing extra shall become payable to the contractor by the Owner for executing the remedial measures.

3.26 Water stops

3.26.1 Material

The material for the PVC water stops shall be a plastic compound with the basic resin of polyvinyl chloride and additional resins, plasticizers, inhibitors, which satisfies the performance characteristics specified below as per IS: 12200. Testing shall be in accordance with IS: 8543.

a)	Tensile strength	3.6 N/mm ² minimum
b)	Ultimate elongation	300% minimum
c)	Tear resistance	4.9 N/mm ² minimum
d)	Stiffness in flexure	2.46 N/mm ² minimum
e)	Accelerated extraction I) Tensile strength II) Ultimate elongation	10.50% N/mm ² minimum 250% minimum
f)	Effect of Alkali i) Weight increase ii) Weight decrease	7 days 0.10% maximum 0.10% maximum ±5points
g)	Effect of Alkali i) Weight increase ii) Weight decrease	28 days 0.40% maximum 0.30% maximum ±1%

PVC water stops shall be either of the bar type, serrated with centre bulb and grips for use within the concrete elements or of the surface (Kicker) type for external use.

PVC water stops shall be of approved manufacture. Samples and the test certificate shall be got approved by the Engineer-in-charge before procurement for incorporation in the works.

3.26.2 Workmanship

Water stops shall be cleaned before placing them in position. Oil or grease shall be removed thoroughly using water and suitable detergents.

Water stops shall be procured in long lengths as manufactured to avoid joints as far as possible. Standard L or T type of intersection pieces shall be procured for use depending on their requirement. Any non-standard junctions shall be made by cutting the pieces to profile for jointing. Lapping of water stops shall not be permitted. All jointing shall be of fusion welded type as per manufacturer's instructions.

Water stops shall be placed at the correct location/level and suitably supported at intervals with the reinforcement to ensure that it does not deviate from its intended position during

concreting and vibrating. Care shall also be taken to ensure that no honey-combing occurs because of the serrations/end grips, by placing concrete with smaller size aggregates in this region. Projecting portions of the water stops embedded in concrete shall be thoroughly cleaned of all mortar/concrete coating before resuming further concreting operations. The projecting water stops shall also be suitably supported at intervals with the reinforcement to maintain its intended position during concreting so as to ensure that it does not bend leading to formation of pockets. In addition, smaller size aggregates shall be used for concreting in this region also.

3.27 Preformed Filler sand Joint Sealing Compound

3.27.1 Materials

Preformed filler for expansion/isolation joints shall be non-extruding and resilient type of bitumen impregnated fibers conforming to IS: 1838 (Part I)

Bitumen coat to concrete/masonry surfaces for fixing the preformed bitumen filler strip shall conform to IS: 702. Bitumen primer shall conform to IS: 3384. Sealing compound for filling the joints above the preformed bitumen filler shall conform to Grade "A" as per IS: 1834

3.27.2 Workmanship

The thickness of the preformed bitumen filler shall be 25 mm for expansion joints and 50 mm for isolation joints around foundation supporting rotatory equipments. Contractor shall procure the strips of the desired thickness and width in length as manufactured.

Assembly of small pieces/thickness of strips to make up the specified size shall not be permitted.

The concrete/masonry surface shall be cleaned free from dust and any loose particles. When the surface is dry, one coat of industrial blown type bitumen of grade 85/25 conforming to IS: 702 shall be applied by brushing at the rate of 1.20Kg/sq.m.

When the bitumen is still hot the preformed bitumen filler shall be pressed and held in position till completely adheres. The surface of the filler against which further concreting/masonry work is to be done shall similarly be applied with one coat of hot bitumen at the rate of 1.20Kg/sq.m.

Sealing compound shall be heated to a pouring consistency for enabling it to run molten in a uniform manner into the joint. Before pouring the sealing compound, the vertical faces of the concrete joint shall be applied hot with a coat of bitumen primer conforming to IS: 3384 in order to improve the adhesive quality of the sealing compound.

Expansion joints between beams/slabs shall be provided with 100mm wide x4mm thick mild steel plate at the soffit of RCC beams/slabs to support and prevent the preformed joint filler

dislodging. This plate shall be welded to an edge angle of IS A 50x50x6 mm/slabs, by intermittent fillet welding. Steel surfaces shall be provided with 2 coats of red oxide zinc chrome primer and 3 coats of synthetic enamel paint finish.

CONCRETEPOURCARD				
POURNO:		DATE:		
DRGNO:		STRUCTURE:		
CONCRETE GRADE QUALITY:		MAX.		
AGGREGATE SIZE:				
Sr no.	Item			Remarks if any
1.	BEFORE CONCRETION	Center lines checked	Yes/No.	
2.		Form work and Staging checked for accuracy, Strength & finish	Yes/No.	
3.		Reinforcement checked	Yes/No.	
4.		Cover to reinforcement checked	Yes/No.	
5.		Verified test Certificate for cement/steel	Yes/No.	
6.		Adequacy of materials/equipment for pour	Yes/No.	
7.		Embedded parts(location & plumb)	Yes/No.	
8.	SOFFIT(S) & POUR TOP (T) LEVELS CHECKED BEFORE(B) & AFTER(A)FORM REMOVAL (ONLY OF BEAMS OF OVER 10M SPAN & IMPORTANT		S(B) T(B) S(B) T(B)	
9.	CONSTRUCTIONJOINTSLOCATION&TIME (IF NOT AS PER DRAWING)			
10.	CEMENT CONSUMPTION IN KGS.			
11.	NUMBER OF CUBES AND IDENTIFICATION			
12.	TEST CUBE RESULTS(7 DAYS/28 DAYS)			
13.	CONCRETE CONDITION ON FORM REMOVAL		Very good/ good/fair /poor	

Notes: -Each pour to have separate cards, in triplicate one each for Owner/client, Contractor& site office.

Under remarks indicate deviations from drawings & specifications, congestion in reinforcement if any, unusual occurrences such as failure of equipment's, sinking of supports/Props, heavy rains affecting concreting, poor compaction, improper curing, other deficiencies, observation etc.

3.28 MODE OF MEASUREMENT AND PAYMENT

The unit rate for concrete work under various categories shall be all inclusive and no claims for extra payment on account of such items as leaving holes, embedding inserts, etc. shall be entertained unless separately provided for in the schedule of quantities. No extra claim shall also be entertained due to change in the number, position and / or dimensions of holes, slots or openings, sleeves, inserts or on account of any increased lift, lead of scaffolding etc. All these factors should be taken into consideration while quoting the unit rates. Unless provided for in the Schedule of Quantities the rates shall also include fixing in sets in all concrete work, whenever required.

Payments for concrete will be made on the basis of unit rates quoted for the respective items in the Schedule of Quantities. No deduction in the concrete quantity will be made for reinforcements, inserts etc. and opening less than 0.100 of a sq.m in areas where concrete is measured in sq.m and 0.010cu.m where concrete is measured in cu.m. Where no such deduction for concrete is made, payment for shuttering work provided for such holes, pockets, etc. will not be made. Similarly the unit rates for concrete work shall be inclusive or exclusive of shuttering as provided for in the Schedule of Quantities.

Payment for beams will be made for the quantity based on the depth being reckoned from the underside of the slabs and length measured as the clear distance between supports. Payment for columns shall be made for the quantity based on height reckoned upto the underside of slab / beams.

The unit rate for precast concrete members shall include formwork, mouldings, finishing, hoisting and setting in position including setting mortar, provision of lifting arrangement etc. complete. Reinforcement and inserts shall be measured and paid for separately under respective item rates.

Only the actual quantity of steel embedded in concrete including laps as shown on drawings or as approved by Engineer shall be measured and paid for, irrespective of the level or height at which the work is done. The unit rates for reinforcement shall include lap chairs, spacer bars etc.

Item No.13 Schedule B1 & Item no-9 Schedule B2 & Item no-12 Schedule B3

Cement Plaster Without Neeru Finish

Material:

Water shall conform to M-1.

Cement Mortar shall conform to M-11

Workmanship:

12 mm thick cement plaster in single coat in CM 1:3 (1-cement : 3-sand) with a floating coat of neat cement slurry.

Scaffolding:

Wooden bullies, bamboos, planks, treatles and other scaffolding shall be sound. These shall be properly examined before erection and use. Stage scaffolding shall be provided for ceiling plaster which shall be independent of the walls.

This kind of Plaster is normally for interior side or as specified location by Consultant to be applied as above. NORMAL CEMENT PLASTER and the surface shall be rubbed smooth after coating it with a thick coat of pure Portland cement slurry while the base coat is still fresh. If Neeru plus cement finish is specified floating with neat cement will not be required.

Mode of Measurement & Payment:

The rate shall include the cost of all materials labour and scaffolding etc. involved in the operations described under workmanship.

All plaster shall be measured in square meter unless otherwise specified length, breadth or height shall be measured correct to a centimeter.

Thickness of the plaster shall be exclusive of the thickness of the key i.e. grooves or open joints in brick work, stone work etc. or space between laths. Thickness of plaster shall be average thickness with minimum 10 mm at any point on this surface.

This item includes plastering up to floor two level.

The measurement of wall plastering shall be taken between the walls or partition (dimensions before plastering being taken) for length and from the top of floor or skirting to ceiling for height, depth of cover of cornices, if any, shall be deducted.

Soffits of stairs shall be measured as plastering on ceilings. Elowigns soffits shall be measured separately.

For jambs, soffits, sides, etc. for openings not exceeding 0.5 sq.mt. each in area for ends of joints, beams, posts girders, steps etc. not exceeding 0.5 sq.mt. each in area and for openings exceeding 0.5 sq.mt. and not exceeding

3.00 sq.mt. in each area deductions and additions shall be made in the following manner:

- a) No deductions shall be made for ends of joints, beams, posts etc. and openings not exceeding 0.5 sq.mt. each and no addition shall be made for reverse, jambs, soffits, side etc. of these openings, for finish to plaster around ends of joints, beams, posts etc.

- b) Deductions for openings exceeding 0.5 sq.mt. but not exceeding 3.00 sq.mt. each shall be made as following and no addition shall be made for reverse, joints, soffits, sides, etc. of these openings.
- i) When both faces of all walls are plastered with same plaster. Deductions shall be made for one face only.
- ii)
- ✓ For openings having door squares equal to or projecting beyond the thickness of wall. Full deduction for opening shall be made from each plastered face of the wall.
 - ✓ In case of openings of area above 3 sq.mt. each deduction shall be made for opening but Jambs, soffits and slits shall be measured.

The rate shall be for a unit of square meter.

Item No.12 Schedule B1 & Item no-10 Schedule B2 & Item no-13 Schedule B3:

20 mm. thick sand face cement plaster on walls and RCC structure up to height of 10 mt. and above ground level consisting of 12 mm thick backing coating of C.M. 1:3 (1 cement : 3 sand) and 8 mm thick finishing coat in C.M. 1:2 (1 cement: 2 sand) etc. complete

Material:

Water shall conform to M-1.

Cement Mortar shall conform to M-11

Workmanship:

The work shall be carried out in the coats. The backing coat (base coat) shall be 12 mm thick in C.M. 1:3. The relevant specification is below:

Scaffolding:

Wooden bullies, bamboos, planks, treatles and other scaffolding shall be sound. These shall be proper examined before erection and use. Stage scaffolding shall be provided for ceiling plaster which shall be independent of the walls.

Preparation of background:

The surface shall be cleaned of all dust, loose mortar, droppings, traces of algar, efflorescence and other foreign matter by water or by brushing if it is not hard and by hacking if it is hard. In case of concrete surface, if a chemical retarder has been applied to the form work, the shall be roughed by wire brushing and all the resulting dust and loose particle cleared off and care shall be taken that none of the retarders is left on the surface. Trimming of projections on brick / concrete surfaces where necessary shall be carried out to get on even surface.

Raking of joints in case of masonry where necessary shall be allowed to dry out for sufficient period before carrying out the plaster work. The work shall not be soaked but only damped evenly before applying the plaster. If the surface becomes dry, such are shall be moistened again.

For external plaster, the plastering operation shall be started from top floor and carried downwards for internal plaster, the plastering operations may be started whenever the building frame and cladding work are ready and the temporary supports of the ceilings on the wall of the floor have been removed. Ceiling plaster shall be completed before starting plaster to walls.

The plaster about 15 x 15 cms shall be first applied horizontally and vertically at not more than 2 meters intervals over the entire surface to serve as gauge. The surfaces of these gauges shall be truly in plane of the finished plastered surface. the mortar shall than be applied in uniform surface slightly more than the specified thickness, then brought to a true surface by marking a wooden straightedge reaching across the gauges with small upward and sideways movements at a time finally the surface shall be finished off true with a trowel or wooden float according as a smooth or a sandy granular texture is required. Excessive troweling or over working the float shall be avoided. All corners, arises angles and junctions shall be truly vertical or horizontal as the case may be and shall be carefully finished. Rounding or chamfering corners, arises junctions etc. shall be carried out with proper templates to the size required.

Cement plaster shall be used half an hour after addition of water, and mortar or plaster which is partially set shall be rejected and removed forthwith from the site.

In suspending the work at the end of the day, the plaster shall be left out clean to the line both horizontally and vertically. When recommencing the plaster, the edges of the old work shall be scrapped clean and wetted with cement putty before plaster is applied to the adjacent areas to enable the two to properly join together. Plastering work shall be closed at the end of the day on the body of features such as plaster bonds and cornices nor at the corners or arises. Horizontal joints in plaster work shall not also occur on parapet tops and copings as these invariably lead to leakage. No portion of the surface shall be left out initially be packed up later on the outside of the plaster and keeping them wet.

The thickness of back coat shall be 12 mm average. Before the first coat hardens its surface shall be beaten up by edges of wooden tapers and close dents shall be made on the surface. The subsequent coat shall be applied after this coat has been allowed to set for 3 to 5 days depending upon the weather conditions. The surface shall not be allowed to dry during this period.

the second coat be started over right after finishing of plaster. The plaster shall be kept wet for a period of 7 days. During this period, it shall be protected from all damages.

Mode of measurements & Payments:

The rate shall include the cost of all materials labour and scaffolding etc. involved in the operations described under workmanship.

All plaster shall be measured in square meter unless otherwise specified length, breadth or height shall be measured correct to a centimeter.

Thickness of the plaster shall be exclusive of the thickness of the key i.e. grooves or open joints in brick work, stone work etc. or space between laths. Thickness of plaster shall be average thickness with minimum 10 mm at any point on this surface.

This item includes plastering upto floor two level.

The measurement of wall plastering shall be taken between the walls or partition (dimensions before plastering being taken) for length and from the top of floor or skirting to ceiling for height, depth of cover of cornices, if any, shall be deducted.

Soffits of stairs shall be measured as plastering on ceilings. Elowigns soffits shall be measured separately.

For jambs, soffits, sides, etc. for openings not exceeding 0.5 sq.mt. each in area for ends joints, beams, posts girders, steps etc. not exceeding 0.5 sq.mt. each in area and for openings exceeding 0.5 sq.mt. and not exceeding 3.00 sq.mt. in each area deductions and additions shall be made in the following manner:

- a) No deductions shall be made for ends of joints, beams, posts etc. and openings not exceeding 0.5 sq.mt. each and no addition shall be made for reverse, jambs, soffits, side etc. of these openings, for finish to plaster around ends of joints, beams, posts etc.
- b) Deductions for openings exceeding 0.5 sq.mt. but not exceeding 3.00 sq.mt. each shall be made as following and no addition shall be made for reverse, joints, soffits, sides, etc. of these openings.
 - i) When both faces of all walls are plastered with same plaster. Deduction shall be made for one face only.
 - ii)
 - For openings having door squares equal to or projecting beyond the thickness of wall. Full deduction for opening shall be made from each plastered face of the wall.
 - In case of openings of area above 3 dq.mt. each deduction shall be made for opening but Jambs, soffits and slits shall be

- measured.
- The rate shall be for a unit of square meter.

Item no-6 Schedule B1 & Item no-11 Schedule B2 & Item no-14 Schedule B3

Supply & Fixing of Broken Glazed (China Mosaic) tiles size 5-6 mm thick of different size and shade (approved crazy pattern) in Cement: Mortar 1:2 and joint filling with White Cement / Coloured Cement including Ramping, Watering, Curing etc. complete

The work is to be carried out with supply and fixing of Broken Glazed (China Mosaic) tiles of size 5-6 mm thick of different size and shade (approved crazy pattern) in C M 1:2 and joint filling with white cement / coloured cement including ramping, watering, curing etc complete with

25 mm bedding of cement mortar 1:6 with required slope. The whole work of this item is to be carried out and completed as per the instructions of engineer in charge.

The rate shall be for a unit of one square meter basis

Item No.7 Schedule B1 & Item No.16 Schedule B3 & Item No.13 Schedule B2 & Item No.12 Schedule B2 & Item No.7 Schedule B1 & Item No.15 Schedule B3 :

Supply & fixing of Vitrified flooring work (1st quality)

Supply & Fixing of Glazed tiles (1st Quality) of required size in Cement Roga and joints to be filled with white cement after 12mm rough plaster in proportion of 1:3 &

MATERIALS

GLAZED TILES / VITRIFIED TILES (1ST QUALITY)

The tiles shall be of best quality as approved by the Engineer-in-charge. They shall be float and true to shape. They shall be free from cracks, crazing spots, chipped edges and corners. The glazing shall be of uniform shade.

Variation from the stated sizes, other than the thickness of tile shall be plus or minus 1.5mm.

The thickness of tile shall be 6 mm except as above the tiles shall confirm to I.S. Latest edition.

BEDDING

The sub-grade shall be cleaned, wetted and mopped. The bedding shall then be laid evenly over the surface tamped and corrected to desired level and allowed to harden enough to offer a rigid cushion to tiles and to enable the mason to place wooden planks across and equal on it.

The Color vitrified tiles shall be laid on cement mortar bedding of 10 mm thick in C.M. 1:3. The mortar shall have sufficient plasticity for laying and there shall be no hard lumps that would

interfere with the evenness of bedding .The base shall be cleared and well wetted .The mortar shall then be spread in thickness not less than10mm at any place and average 12mm thickness. The proportion of the cement mortar shall be as specified in the item.

FIXING TILES

The tiles before laying shall be soaked in water for at least two hours. Neat grey cement grout at 3.3 Kg. Cement / Sq. Mt. of honey like consistency shall be spread over the mortar bedding as directed. The edges of the tiles are smeared with neat cement slurry. The tiles shall be well pressed and gently tapped with a wooden mallet till they are properly bedded and in level with the adjoining tiles. There shall be no hollows in bed or joints. The joints between the tiles shall be as thin as possible in straight line or as per pattern.

The tiles shall not have staggered joints. The joints shall be true to centre line both ways. The Nahni trap coming in the flooring shall be so positioned that its grating shall replace only on tile as far as possible. Where full size tiles cannot be fixed, they shall be cut (Swan)to the required size and the edges rubbed smooth to ensure straight and true joints.

The joints shall be filled with grey cement grout/Epoxy grout with wire brush or trowel to a depth of 5mm and loose material removed. White cement or Epoxy grout shall be used for pointing the joints. After fixing the tile finally in an even plane the flooring shall be kept wet and allowed to nature undisturbed for 7days.

CLEANING

The surplus Epoxy grout or cement grout that may have come out of the joints shall be cleared off before it sets. Once the floor has set, it shall be carefully washed, cleared by dilute acid and dried. Proper precaution and measures shall be taken to ensure that the tiles are not damaged many way still the completion of the construction.

No Extra payment shall be paid for Epoxy grout in jointing of tiles.

Mode of Measurement:

The rate for this item will be paid on one square meter basis.

ItemNo.14 Schedule B2 & ItemNo.17 Schedule B3:

Supplying and fixing alluminium frame 62.50 x 25 mm. size and 37.50 x 18mm size shutter with sliding frame 2-track of standard company etc. complete.

Providing and fixing alluminium frame 62.50x25mm.size and 37.50x18mm size shutter with sliding frame 2- track of standard company as directed by the engineer-in- charge etc. complete.

The rate for this work will be paid per square meter basis.

Item No.15 Schedule B1 & Item No.15 Schedule B2 & Item No.18 Schedule B3:

Apex Color work on Outer side of Wall (Two coats) (with Base Coat) FINISHES

EXTENT AND INTENT

The Contractor shall supply all materials, labour, tools, ladders, scaffolding and other equipment necessary for the completion and protection of all painting / finishing work. Painting & finishing, as herein specified shall be applied to all surfaces requiring painting / finishing throughout the interior and exterior of the buildings as given in the schedule of finishes or elsewhere. The painting / finishing shall be carried out by a specialist workers, approved by the Engineer- in-charge of RMC for this work.

STORAGE

Storage of materials to be used on the job shall be, only in a single place approved by the Engineer-in-charge of RMC for this work. Such storage place shall not be located within any of the buildings included in the contract.

MATERIALS

Materials used in the work shall be of manufacture approved by the Engineer-in- charge of RMC for this work, Ready mixed paints, varnishes, enamels, lacquers, stains, paste fillers, distempers and other materials must be delivered to the job site in the original containers, with the seals unbroken and labels intact. Each container shall give the manufacturer's name, type of paint, color of paint and instructions of reducing. Thinnings shall be done only in accordance with directions & manufacturer's specification. Remove rejected materials immediately from the premises.

SHADES

All shades, as provided in the shade schedule, shall be approved by the Engineer- in-charge of RMC for this work. The Contractor shall as far as possible use pre- mixed manufacturer's shades and shall prepare sample of the shades selected and submit same for approval by the Engineer-in-charge of RMC for this work. No work is to proceed until the Engineer-in-charge of RMC for this work has given his approval, preferably in writing, of the shade samples.

COMMENCEMENT OF WORK

Painting / finishing shall not be started until the surfaces to be painted / finished are in a condition fit to receive painting / finishing and so certified by the Engineer-in-charge of RMC for this work.

Painting / finishing work shall be taken in hand only after all other civil work is completed.

Buildings where painting / finishing work is to commenced shall be thoroughly swept and cleaned up before commencement of painting / finishing.

SCAFFOLDING

Only double scaffolding having two sets of vertical supports shall be provided for all, painting / finishing work. The supports shall be tied together with horizontal pieces over which the scaffolding planks shall be fixed.

All the vertical and horizontal members of the scaffolding shall be placed sufficiently away from the surfaces to be painted to ensure proper and unit erupted application.

WORKMANSHIP

The workmanship shall be of the very best; all materials evenly spread and smoothly flowed as without running sags, using good quality tools, brushes, etc., as required. Only skilled painters / applicators shall be employed. A properly qualified foreman shall be constantly on the job whilst the work is proceeding. All surfaces to be painted / finished shall be cleaned free of all loose dirt and dust before painting / finishing is started. All work where a coat of material has been applied must be inspected and approved before application of the succeeding specified coat. Each undercoat shall be distinct shade of the approved color.

Before painting / finishing, remove hardware, accessories, plates and similar items or provide portion to all such items. Upon completion of each space, replace all fixtures removed. Remove doors if necessary to paint bottom edge. Use only skilled mechanics for the removal and replacement of above items.

CONCEALED SURFACES

All interior and exterior trim, door frames, doors, shelving, cabinet work shall be thoroughly and carefully back painted as all surfaces and edges which will be concealed when installed. Such surfaces shall be clean, dry, sanded and properly prepared to receive the paint. Tops, bottom and edges of doors shall be finished same as the rest of the door.

PROTECT AND CLEAN

The agency shall protect not only his own work at all times, but shall also protect all adjacent work and materials by suitable covering during progress of his work. Upon completion of his work, he shall remove all paint and varnish spots from floors, glass and other surfaces. Any defaced surfaces shall be cleaned and the original finish restored. He shall remove from the premises all rubbish and accumulated material and shall leave the work in clean, orderly and acceptable conditions.

PREPARATION OF SURFACES

PLASTER WORK: Fill all holes, cracks and abrasions with plaster of parish / cement slurry as directed, properly prepared and applied and smoothed off to match adjoining surfaces. Do not use sand paper on plaster surfaces. Plaster shall be allowed to dry for at least 12 (twelve) weeks before the application of paint / finishes.

STEEL AND IRON: All surfaces shall be washed with mineral spirits to remove any dirt or grease before applying paint. Where rust or scale is present, it shall be wire brushed and sand papered clean. All cleaned surfaces shall be given one coat of approved phosphate before prime coat in accordance with the manufacturers, Instructions. Shop coats of paint that have become marred shall be cleaned off, wire brushed, and spot primed over the affected areas.

APPLICATION

The paint shall be continuously stirred in the container so that its consistency is kept uniform throughout.

The painting / finishing shall be laid on evenly and smoothly by means of crossing and laying off, the latter in the direction of the grain of the wood. The crossing and laying off consists of covering the area with paint, brushing the surface hard for the first time and then brushing alternatively in opposite directions, two or three times and then finally brushing lightly in a direction at right angles to the same. In this process no brush marks shall be left after the laying off is finished. The full process of crossing and laying off will constitute one coat.

Where so stipulated, the painting / finishing shall be carried out using spray machines suited for the nature and location of the work to be carried out. Only skilled and experienced workmen shall be employed for this class of work. Paints used shall be brought to the requisite consistency by adding a suitable thinner. Spraying shall be carried out only in dry conditions. No exterior painting / finishing shall be done in damp foggy or rainy weather. Surface to be painted shall be clean, dry, smooth and adequately protected from dampness. Each coat shall be applied in sufficient quantity to obtain complete coverage, shall be well brushed and evenly worked out over the entire surface and into all corners, angles and crevices allowed to thoroughly dry. Second coat shall be of suitable shade to match final color, and shall be approved by the Engineer-in-charge of RMC for this work before final coat is started. Allow at least 48 hours drying time between coats for interior and 7 days for exterior work, and if in the judgment of the Engineer-in-charge of RMC for this work more time is requested it shall be allowed. Finished surfaces shall be protected from dampness and dust until completely dry. Finished work shall be uniform of approved color, smooth and free from runs, sags, defective brushing and clogging. Make edges of paints adjoining materials of colors sharp and clean, without overlapping.

In order to achieve a superior finished surface, putty paste fillers shall be used on, all surfaces to be painted. To fill pores, dents, etc. The putty / paste fillers shall be approved quality and manufacture and shall be applied to the surface with a knife or other sharp edged tools after the priming coat as well as after each undercoat. The surface, after filling with putty / paste tiller, shall be rubbed down with fine sand paper and dusted off before the

application of the subsequent coat. Paste wood filler when set shall be wiped across the grains of the wood and then with the grain to secure a clean surface. Surface to be stained shall be covered with uniform coat of stain wiped off if required.

FINISH: The painted surfaces shall be finished to require texture. Matt finish shall be achieved by use of sponge rollers or stippling brushes as called for.

The rate shall be paid for a unit of one square meter basis.

Item No.16 Schedule B2 & Item No.19 Schedule B3:
Brick work 1:6

Materials:

Water shall conform to M-1.

Cement:

Cement shall conform to M-3.

Brick:

The bricks shall be hard or machine moulded and made from suitable soils and burnt. They shall be free from cracks and flaws and nodules of free lime. They shall have smooth rectangular faces with sharp corners and shall be of uniform colors.

The bricks shall be moulded with a frog of 100 mm x 40 mm and 10 mm to 20 mm deep on one of its flat sides. The bricks shall not break when thrown on the ground from a height of 600 mm. The size of modular bricks shall be 190 mm x 90 mm.

The size of the conventional bricks shall be as under:
(9" x 4.3/8" x 2,3/4") 225 x 110 x 75 mm

Only bricks of one standard size shall be used in one work. The following tolerances shall be permitted in the conventional size adopted in a particular work.

Length $\pm 1/8"$ (3mm) width :
 $\pm 1/16"$ (1.5mm) Height: \pm
 $1/16"$ (1.5 mm)

The crushing strength of the bricks shall not be less than 35 kg/sq.cm. The average water absorption shall not be more than 20 percent by weight. Necessary tests for crushing strength and water absorption etc., shall be carried out as per IS: 3495 (Part I to IV) - latest edition.

Workmanship:

i) Proportion:

The proportion of the cement mortar shall be 1:6 (1-Cement, 6-Fine sand) by volume.

Wetting of bricks:

The bricks required for masonry shall be thoroughly wetted with clean water for about two hours before use or as directed. The cessation of bubbles, when the bricks are wetted with water is an indication of thorough wetting of bricks.

Laying:

Bricks shall be laid in English bond unless directed otherwise. Half or cut bricks shall not be used except when necessary to complete the bond; closer in such case shall be cut to required size and used near the ends of walls.

A layer of mortar shall be spread on full width for suitable length of the lower course. Each brick shall first be properly bedded and set frame by gently tapping with handle of trowel or wooden mallet. Its inside face shall be flushed with mortar before the next brick is laid and pressed against it. On completion of course the vertical joints shall be fully filled from the top with mortar.

The work shall be taken up truly in plumb. All courses shall be laid truly horizontal and all vertical joint shall be truly vertical. Vertical joints in alternate course shall generally be directly one over the other. The thickness of brick course shall be kept uniform.

The brick shall be laid with frog upwards. A set of tools comprising of wooden straight edges, mason's spirit level, square half meter rub, and pins, string and plumb shall be kept on site of work for frequent checking during the progress of work.

Both the faces of walls of thickness greater than 23 cms shall be kept in proper place. All the connected brick work shall be kept not more than one meter over the rest of the work. Where this is not possible, the work shall be raked back according to bond (and not left toothed) at an angle not steeper than 45 degrees.

All fixtures, pipes, outlets of water, hold fasts of doors and windows etc. which are required to be built in wall shall be embedded in cement mortar.

Joints:

Bricks shall be so laid that all joints are quite flush with mortar. Thickness of joints shall not expose 12 mm. The face joints shall be raked out as directed by raking tools daily during the progress of work when the mortar is still green so as to provide key for plaster or pointing to done.

The face of brick shall be cleaned the very day on which the work is laid and all mortar dropping removed.

Curing:

Green work shall be protected from rain suitably. Masonry work shall be kept moist on all the faces for a period of seven days. The top of masonry work shall be kept well wetted at the close of the day.

Proportion of foundation bed:

If the foundation is to be laid directly on the excavated bed, the bed shall be leveled, cleared of all loose materials, cleaned and wetted before string masonry is to be laid on concrete footing, the top of concrete shall be cleaned and moistened. The contractor shall obtain the engineer's approval for the foundation bed before foundation masonry is started. When precast flooring is to be provided flush with the top of plinth, the inside plinth offset shall be kept lower than the outside plinth top by the thickness of the following.

Mode of measurement & Payment:

The measurement of this item shall be taken for the brick masonry fully completed in foundation upto plinth. The limiting dimensions not exceeding those shown on the plans or as directed shall be final. Battered tapered and curved position shall be measured net.

Item No.17 Schedule B2:

Brick Masonry Partition Wall in Cement : Mortar 1:4 (3.5 to 4.5 inch thick)

1. Materials

Bricks shall conform to M-15. Water shall conform to M-1. Cement shall conform to M-3. Sand shall conform to M-6. Cement mortar shall conform to M-11.

2. Workmanship

The relevant specifications be followed for bricks, wetting, laying of bricks, joints, curing, shall conform to Item No.5 expect that the bricks to be used shall be conventional bricks instead of modular bricks.

Cement mortar used in masonry work shall be in proportion of 1 part of cement and 4 parts of sand by volume.

All bricks shall be laid stretcher wise, breaking joints with those in the upper and lower courses. The wall shall be taken truly plumb. All courses shall be laid truly horizontal and all vertical joints shall be truly vertical. The bricks shall be laid with frogs upwards. A set of masons tools shall be maintained on work as required for frequent checking.

3. Mode of measurements and payment

The limiting dimensions shall not exceed those shown in the plan or as directed. Any work done extra over specified dimensions shall be ignored.

The rate shall be for a unit of one square meter.

Item No.18 Schedule B2 & Item No.24 Schedule B3: Supply and laying of machine crushed aggregate of 25-38 mm size

Machine Crushed metal shall be of approved quarry and it should be approved by the In-charge Site Engineer prior to collection.

The machine crushed metal shall be hard, tough, sound, durable, black trap field metal of close texture, with the decay and weathering. Each piece of the stone shall be angular and roughly cubical in shape and round elongated or flaky material shall be rejected. No round or oblong pebbles or at guar chips larger or smaller than specified size shall be allowed.

All unsound, weathered or disinclined stone obtained from the upper surface layer of the quarry or other layer of boulders shall be rejected. The physical requirement for standard size metal shall conform to the test results indicated in Table No.1. The metal shall be nearly uniform in size as possible and shall conform to following minimum requirements of passing through the rings.

The physical requirement for standard size metal shall conform to the test results indicated in the Table No.1 below:

Table No.1

Type of Const.	Test Method	Requirement
Base (a) Los Angelos abrasion Value Or	IS: 2386 Part iv	50 % (Max.)
Aggregate Impact Value.	IS 2386 Part iv or IS :5640	40 % (Max.)
(b) Flakiness index & Elongation Index	IS :2386 Part I	30 % (Combined.)
(c) Water Absorption	IS: 2386 Part-3	2% (Max.)

Table No.2

Grading No.	Size Rang	IS Sieve Designation	Per cent by weight passing
2	25 mm to 38 mm	90 mm	100
		63 mm	90-100
		53 mm	25-75
		45 mm	0-15
		22.4 mm	0-5

Wherever and doubt exists as to whether the above requirements are satisfied in whole or part. The collection of M.C. metal shall be got screened by the contractor, it so ordered by the In-charge Site Engineer and for which no extra payments shall be claimed by the contractor.

Any collection which does not fully satisfy the above requirements is liable to be rejected altogether. Frequency of test shall be as per Ministry of Surface Transport Specifications. Agency has to submit complete drawing of leveling after each layer of work as mentioned in Special Conditions of Contract.

Also, the work is to be carried out with Mini Roll / Road Roller / Hand Rolls may be required for the work as per the requirement and instructions of engineer in charge.

The measurements shall be taken on cubic meter basis.

**Item No.22 Schedule B1 & Item No.19 Schedule B2 & Item No.26 Schedule B3:
FRP Door supply all fitting and fixture complete**

Providing and fixing 28 mm thick single shutter door with flush depressed panel design with core material PU foam done in situ & sandwich panel of 4 mm thick plywood & moulded in wooden blocks for fixtures. FRP thickness to be 1.50 mm to 2.00 mm including providing and fixing FRP moulded section frame of section size 100 mm x 50 mm chamfered type with FRP thickness of 2.00 mm and core of rigid polyurethane foam having density 32 Kg/ cmt to 36 Kg/cmt., compressive strength 3.5 Kg./sqcm to 4.5 Kg./sqcm. and fire retardant grade, PU foam shall be done situ with Canadian Ponderosa wooden blocks for fixtures. In built holdfast arrangement to use fasteners for fixing with masonry or R.C.C. The whole section of frame and shutter shall be waterproof, acid / alkali resistant & well coat colour. the frame and shutter shall be fixed with all necessary stainless steel fixtures and fastenings etc. complete as per direction of engineer in charge.

Materials:-

Frame materials shall be of fire extinguishing grade FRP skin having section 100 mm x 50 mm chamfered type with thickness of 1.50 mm to 2.00 mm and core material shall be fire extinguishing grade rigid polyurethane foam having density 32 Kg/ cu.cm to 36 Kg/ cu.cm, flexural strength 1.8 Kg / Sqcm to 2.00 Kg / Sqcm and compressive strength 3.5 Kg / Sqcm to 4.5 Kg / Sqcm. Whole frame shall be water proof, weather proof, termite proof and mild acid / alkali resistance. P.U foam shall be done in situ with plantation wooden pieces embedded inside for holding fixtures and stiffening. Frame shall be straight in line, level and having three joint- less pieces. Frame shall be fixed in masonry / R.C.C with Mild Steel holdfast or with 115 mm long screws as hold fast with sleeve in position and finished in colour cement. 28 mm thick shutter in depressed panel design shall be

having 1.5 mm to 2.0 mm thickness fire extinguishing grade FRP skin, sand- witch panel of 4 mm thick plywood and embedded wooden pieces for stiffening as well as holding hinges and fixture, all molded into a one piece shutter. Core material shall be injected fire extinguishing grade rigid polyurethane foam done in situ having density 32 Kg / Cucm to 36 Kg / Cucm compressive strength 1.8 Kg / Sqcm to 2.00 Kg / Sqcm, flexural strength 3.5 Kg / Sqcm to 4.5 Kg / Sqcm. Whole shutter shall be water proof, weather proof, termite proof and mild acid/alkali resistance. 28 mm thick depressed panel FRP shutter shall be joint-less. It shall be straight and smooth and of standard shape finished in gel coat. All necessary fixture and fastening shall be fixed where wooden pieces are provided.

Workmanship:

Frame shall be fixed in masonry/R.C.C member. Shutter shall be fixed in true line; level and proper manner having 2.0 to 3.0 ply i.e. air space for smooth and easy working. Pull handles, Door stopper, Door stopper, bearing hinges & S.S self tapping Philips cross head special screws conforming to anti corrosive high grade AISI 304 stainless steel of standard make or as equivalent approved by Engineer-in-charge conforming to anti corrosive high grade AISI 304 stainless steel only, & Tower bolt of the make Orbit or as equivalent approved by Engineer-in-charge conforming to standards of ORBIT & anti corrosive high grade AISI 304 stainless steel only.

All fixtures and fastenings of standard make shall conform to A ISI 304 Grade Stainless Steel.

The following table presents main elements (forming the Chemical composition) of A ISI 316 Grade Stainless Steel.

It can withstand the corrosion caused by atmospheric / environmental or major chemical reactions.

It can resist high temperatures without going under any deformity which makes it highly recommended for fire safety doors in any building.

It shall have remarkable creep strength and Rupture strength.

It shall be repelled the Bacteria & shall be made higher degree of hygiene.

It shall be of natural finish, it shall not required regular cleaning or maintenance making it most suitable for public places.

It shall tolerate forceful and intense use.

Specially developed fixing stud and grubs shall be used to ensure accurate fitting of elements and eliminates shaking of elements.

Fixtures & Fastenings:

Following fixtures and fastening shall be used for single shutter. All fixtures and fastening of the make shall be of anti corrosive high grade A ISI 304 stainless steel in Glossy & satin combination finish only. Fixtures and fastening of standard make shall be fixed by skill person only.

The rate shall include anti corrosive high grade AISI 304 stainless pull handle, hinges, door stopper in Glossy & satin combination finish of the standard make including fixing with S.S self tapping Philips cross head special screws and Stainless steel tower bolt of the make Orbit. The size and number of hinges shall be as per table given above ± 1.50 mm tolerance will be allowed in thickness of shutter and ± 1.20 to 2.00 mm for size of frame.

Mode of measurements & payment:

The rate for shutter includes cost of anti corrosive high grade A ISI 304 stainless pull handle, Door stopper, hinges, S.S self tapping Philips cross head special screws in Glossy & satin combination finish of standard make, tower bolt of the make orbit. The dimensions of the door shall be measured clear size of the opening made for fixing of door with frame.

The rate shall be for a unit of one sq.metre.

Item No.20 Schedule B2 & Item No.27 Schedule B3:

Iron Work as per drawing and Instructions all complete:

All structural steel shall confirm to IS 266 - Latest edition. The steel shall be free from the defects mentioned in IS 226 (Latest edition) and shall have a smooth finish. The material shall be free from loose mill scale, rust, pits or other defects affecting the strength and durability. River bars shall confirm to IS 1148 Latest edition.

When the steel is supplied by the contractor, test certificate of the manufacturer shall be obtained according to IS 226 Latest edition and other relevant Indian Standards.

The design should be made as per the instructions of engineer-in-charge. The rate includes supplying and welding (along with labours), transportation and fixing in position of the steel work.

The rate shall be for a unit of one Kilogram.

Item No.20 Schedule B1 & Item No.21 Schedule B2 & Item No.28 Schedule B3:

Supply & Fixing of Granite Stone on wall after rough cast Cement Plaster in proportion of 1:3 and fixing grainite in Cement Paste (ANY COLOR 2ND CLASS) & Supply & Fixing of Granite Stone (Telephone Black Color) on wall after rough cast Cement Plaster in proportion of 1:3 and fixing grainite in Cement Paste

1.0 Materials

1.1. Water shall confirm to M-1. Lime mortar shall confirm to M-10, Cement mortar shall confirm to M-11, Granite Stone shall confirm to M-52.

2.0. Workmanship

Each slab shall be cut to the required size and shape and fine chisel dressed at all the edges. The sides thus dressed shall have a full contact if a straight edge is laid along. The sides shall be table rubbed with coarse sand before paving. All angles and edges of the slabs shall be true square and free from chippings and giving a plane surface. The thickness shall be 25 mm. (Average) as specified in this item but not less than 20 mm at any place.

Bedding for the stone slabs shall be of cement mortar 1:6 (1 cement :6 coarse sand) of average thickness 20 mm. Sub grade shall be cleaned, wetted and mopped. Mortar of the specified mix and thickness shall be spread on an area sufficient to receive one kota stone slab. The slab shall then be washed clean before laying. It shall be laid on top pressed, tapped gently to bring it in level with the other slabs. It shall then be lifted and laid aside. Top surface of the mortar shall then be corrected by adding fresh mortar at hollows or depressions. The mortar shall then be allowed to harden bit. Over this Surface, cement slurry of honey like consistency shall be applied. The slab shall then be gently placed in position and tapped with wooden mallet till it is properly bedded in level. with and close to the adjoining slab. The joint shall be as fine as possible. The slabs fixed in the floor adjoining the walls shall enter not less than 10 mm. under the plaster, skirting or dedo. The junction between wall and floor shall be finished neatly. The finished surface shall be true to levels and slopes as directed.

The floor shall be kept wet for a minimum period of 7 days so that bedding and joints set properly.

Polishing shall be normally commenced after 14 days of laying the stone slab. First polishing shall be done with carborundum stones of 120 grade grit fitted in the heavy machine and then second polishing shall be done with carborundum stone of 220 to 350 grade grit fitted in heavy machine. Water shall be properly used during polishing. The stone shall then be washed clean with water. When directed by the Engineer-in-charge; wax polish of approved quality shall be applied on the surface with the help of soft cloth over a clean and dry surface. Then the polishing machine fitted with bobs shall be run over it.

The holes required for Nahni traps, pipes and other fittings shall be made without any extra cost.

The kota stone for platform and c.b. shall be supplied and fixed with two side polished and the work shall have to be completed as per requirement and instructions of engineer in-charge.

3.0. Mode of measurements & payment

3.1 The rate shall include the cost of all materials and labour involved in all the operations described above. The kota stone flooring shall be measured in square meters correct to two places of decimal, length and breadth shall be measured correct to a: centimeter and between the finished face of skirting dedo or wall plaster and no deduction shall be made nor extra paid for any opening in floor of areas up to 0.1 sq.mt.

The rate shall be paid for a unit of one sq. meter.

Item No.18 Schedule B1 & Item No.22 Schedule B2 & Item No.29 Schedule B3 :

Enamel painting on door/window, iron door, iron grill or woodwork two coat

Materials :

The ready mixed paint, brushing, wood primer pink shall conform to I.S. 3536 1966 (Latest edition).

Workmanship :

Preparation of Surfaces :

All wood work shall be dry and free from any foreign matter incidental to building operations. Nails shall be punched well below the surface to provide a firm key for stopping. Mouldings shall be carefully smoothed with abrasive paper and projecting fibres shall be removed. Flat portion shall be smoothed off with abrasive paper used across the grain prior to staining and with the grain prior to staining or if the wood is to be left in its natural colour, wood work which is to be stained may be smoothed to scraping instead of by glass papering if so required.

Any knots, resinous or stricaks or blueish sap wood that are not large enough to justify cutting out shall be treated with two coats of pure shellac knotting applied thinly and extended about 25 mm. beyond the actual area requiring treatment.

Application of primer :

The relevant specifications shall be followed for application of primer.

1.0. Materials :

The enamel paint shall conform to M-44 B.

2.0 Workmanship :

General:

The materials required for work of painting work shall be obtained directly from approved manufacturers or approved dealer and brought to the site in maker's drums, kegs etc. with seal unbroken.

2 1.2. All materials not in actual use, shall be kept properly protected, lids of containers shall be kept closed and surface of paint in open or partially open containers covered with a thin layer of turpentine to prevent formation of skin. The materials which have become stale or flat due to improper and long storage shall not be used. The paint shall be stirred thoroughly in its container before pouring into small containers. While applying the paint shall be continuously stirred in smaller container. No left over paint shall be put back into stock tins. When not in use, the containers shall be kept properly closed.

If for any seasons, thinning is necessary, the brand of thinner recommended by the manufacturer shall be used.

The surface to be painted shall be thoroughly cleaned and dusted. All rust, dirt and grease shall be thoroughly removed before painting is started. No painting on exterior or other exposed parts of the work shall be carried out in wet, damp or otherwise unfavourable weather and all the surfaces shall be thoroughly dry before painting work is started.

Application:

Brushing operations are to be adjusted to the spreading capacity advised by the manufacture of particular paint. The paint shall be applied evenly and smoothly by means of crossing and laying off. The crossing and laying off consists of covering the area over with paint, brushing the surface hard for the first lime over and then brushing alternately in opposite directions two or three times and then finally brushing lightly in direction at right angles to the same. In this process, no brush marks shall be left after the laying off is finished. The full process of crossing and laying off will constitute one coat.

Each coat shall be allowed to dry completely and lightly rubbed with very fine grade of sand paper and loose particles brushed off before next coat is applied. Each coat shall vary slightly in shade and shall be got approved from Engineer-in charge before next coat is started.

Each coat except the last coat shall be lightly rubbed down with sand paper of fine pumice stone and cleaned of dust before the next coat is applied. No hair marks from the brush or clogging of paint puddles in the corners of panels angles of mouldings etc. shall be left on the work. Special care shall be taken while painting over bolts, nuts, rivets, overlaps etc. Approved best quality brushes shall be used.

Mode of measurements & payment:

The relevant specifications of item shall be followed for mode of measurements and payment. The rate is excluding priming coat.

The rate shall be for a unit of one sq. meter.

Item No.23 Schedule B2& Item No.30 Schedule B3:
Numbering on Building/Quarters (Painting work)

Painting and Numbering work of various characters of approved quality paints as directed by the engineer-in-charge etc complete.

The rate shall be paid for a unit per character basis.

Item No.16 Schedule B1& Item No.24 Schedule B2 & Item No.31
Schedule B3:
Plastic Emulsion paint (two coats) (Asian Paint, ICI, Dulux,
Nerolac, Berger, etc. of approved type (with prime coat):

Materials:

The enamel paint shall satisfy in general requirements in specifications of oilpaints. Enamel paint shall conform to I S Latest edition.

Workmanship:

The materials required for work of painting work shall be obtained directly from approved manufacturer or approved dealer and brought to the site in maker's drum, bags etc. with seal unbroken.

All materials not in actual use shall be kept properly protected, lids of containers shall be kept closed and surface of paint in open or partially open containers covered with a thin layer of turpentine to prevent formation of skin. The materials which have become state or flat due to improper and long storage shall not be used. The paint shall be stirred thoroughly in its container before pouring into small containers. While applying also, the paint shall be continuously stirred in smaller container. No left over paint shall be put back into store tins. When not in use, the containers shall be kept properly closed.

If for any reasons, thinning is necessary, the brand of thinner recommended by the manufacturer shall be used.

The surface to be painted shall be thoroughly cleaned and dusted. All rust, dirt and grease shall be thoroughly removed before painting is started. No painting on exterior or other exposed parts of the work shall be carried out in wet, damp or otherwise unfavourable weather and all the surfaces shall be thoroughly dry before painting work is started.

Application of paint:

Brushing operations are to be adjusted to the spreading capacity advised by the manufacturer of particular paint. The paint shall be applied evenly and smoothly by means of crossing and laying off. the crossing and laying of consists of covering the area over with paint, brushing the surface hard for the first time over and then

brushing alternately in opposite directions two or three times and then finally brushing lightly in a direction at right angles to the same. In this process, no brush marks shall be left after the laying off is finished. The full process of crossing and laying off will constitute one coat.

Each coat shall be allowed to dry completely and lightly rubbed with very fine grade of sand paper and loose particles brushed off before next coat is applied. Each coat shall vary slightly in shade and shall be got approved from the engineer-in-charge before next coat is started.

Each coat except the last coat shall be lightly rubbed down with sand paper of fine pumice stone and cleared of dust before the next coat is applied. No hair marks from the brush or clogging of paint puddles in the corners of panels, angles of moulding etc. shall be left on the work.

Special care shall be taken while painting over bolts, nuts, rivets, overlaps etc. Approved best quality brushes shall be used.

Mode of measurement and payment:

The new steel and other metal surface shall be measured under this item. All the work shall be measured net in the decimal system as executed subject to the following limits unless otherwise stated hereinafter.

- a) Dimensions shall be measured to the nearest 0.01 meter.
- b) Areas shall be worked out to the nearest 0.01 meter.

No deductions shall be made for openings not exceeding 0.5 sq.m. each and no addition shall be made for painting to beddings, moulding, edges, jambs, soffits, sills etc of such opening.

In case of fabricated structural steel and iron work, priming coat of paint shall be included with fabrication. In case of trusses, if measured is sq.m compound girders, stanchions, lattices, girder and similar work, actual area shall be measured and no extra shall be paid for painting on bolts heads, nuts, washers etc. No addition shall be made to the weight calculated for the purpose of measurements of steel and iron works for paint applied on shop or at site.

The different surfaces shall be grouped into one general item, areas of uneven surfaces being converted into equivalent plain areas in accordance with the table given as per Annexure-II for payment.

The rate is including priming coat.

The rate shall be for a unit of one square meter.

Item No.25 Schedule B2 & Item No.33 Schedule B3:

Making cupboard with 18 mm plywood which 6 mm ply back side. 0.8 mm white lamination inner side. fixing approved quality sunmica. hinges. stopper etc. 18 mm thick ply with

both side lamination for selves. plywood brands - Kitply, Century, Dura, Everest.

The cupboard with 18 mm plywood with 6 mm ply on back side is to be provided and fixed with approved quality material as instructed. 0.8 mm white lamination inner side is to be fixed of approved quality sunmica with hinges, stopper, etc. Both side lamination for selves for 18 mm thick ply is to be done. The Plywood brand shall be Kitply, Century, Dura, Everest. The work as may be instructed by the Site Engineer shall have to be completed.

The rate shall be for a unit of one square meter basis.

Item No.21 Schedule B1& Item No.26 Schedule B2& Item No.34 Schedule B3:

Flush Door 25mm thick (without frame) for Door & window with polishing / oil painting using company viz. Kitply / Century / Dura / Everest

Wooden flush door shutters (solid core) :

The solid core type flush door shutters shall be of decorative or non- decorative type as specified in the drawing. The size and thickness of the shutter shall be as specified in drawings or as directed. The timber species for core shall be used as per I.S. Latest edition. The timber shall be free from decay and insect attack. Knots and knot holes less than half the width of cross-section of the members in which they occur may be permitted. Pitch pockets, pitch streaks and harmless pin holes shall be permissible except in the exposed edges of the core members. The commercial plywood, cross- bands shall conform to I.S: latest edition.

The face panel of the shutters shall be formed by gluing by the hot press process on both faces of the core with either, plywood or cross-bands and face veneers. The lipping, rebating, opening of glazing; venetian etc. shall be provided if specified in the drawing.

All edges of the door shutters shall be square. The shutters shall be free from twist of warp in its plant Both faces of the shutters shall be sand papered to smooth even texture.

The shutters shall be tested for:

1. End immersion test : The test shall be carried out as per I.S. latest edition. There shall be no delamination at the end of the test.
2. Knife test : The face panel when tested in accordance with I.S. latest edition shall pass the test.
3. Glue adhesion test : The flush door shall be tested for glue adhesive test in accordance with I.S.: latest edition. The shutters shall be considered to have passed the test if no

delamination occurs in the glue lines in the plywood and if no single delamination more than 80 mm in length and more than 3 mm in depth has occurred in the assembly glue lines between the plywood face and the style and rail. Delamination at the corner shall be measured continuously around the corner. Delamination at the knots, knot holes and other permissible wood defects shall not be considered in assessing the sample.

The tolerance in size of solid core type flush door shall be as under:
In Nominal thickness ± 1.2 mm in Nominal height ± 3 mm.

The thickness of the shutter shall be uniform throughout with a permissible variation of not more than 0.8 mm: when measured at any two points.

This wooden shutter must be framed with steel section.

Workmanship

The relevant specifications shall be followed except that the shutters be non-decorative type and block board core with face veneer or plywood, with 25 mm thickness.

Readymade shutters shall be of correct size and shall fit into the door or other openings without excessive scrapping of edges. Adding of battens etc., to make up to the size shall not be allowed.

The rate shall be for a unit of one sq.meter.

Item No.8 Schedule B1& Item No.27 & 28 Schedule B2 :

Supply, Fixing & Polishing for Granite Flooring work 18mm thick & 200 mm Base of Lime: Mortar in proportion of 1:2 (telephone black color) & Supply & Fixing of Polished of Kota Stone of required size & thickness as instructed to fixed in Platform / Cup Board etc.

Materials

Water shall confirm to M-1. Lime mortar shall confirm to M- 10, Cement mortar shall confirm to M- 11, Granite Stone shall confirm to M-52.

Workmanship

Each slab shall be cut to the required size and shape and fine chisel dressed at all the edges. The sides thus dressed shall have a full contact if a straight edge is laid along. The sides shall be table rubbed with coarse sand before paving. All angle sand edges of the slabs shall be true square and free from chippings and giving a plane surface. The thickness shall be 25mm. (Average) as specified in this item but not less than 20mm at any place.

Bedding for the Granite stone slabs shall be of lime mortar 1:2(1 lime: 2 coarse sand) of average thickness 20mm. Subgrade shall be cleaned, wetted and mopped. Mortar of the specified mix and thickness shall be spread on an area sufficient to receive one stone slab. The slab shall then be washed clean before laying. It shall be laid on top pressed, tapped gently to bring it in level with the other slabs. It shall then be lifted and laid aside. Top surface of the mortar shall then be corrected by adding fresh mortar at hollows or depressions. The mortar shall then be allowed to harden bit. Over this Surface, cement slurry of honey like consistency shall be applied. The slab shall then be gently placed in position and tapped with wooden mallet till it is properly bedded in level with and close to the adjoining slab. The joint shall be as fine as possible. The slabs fixed in the floor adjoining the walls shall enter not less than 10mm. under the plaster, skirting or dedo. The junction between wall and floor shall be finished neatly. The finished surface shall be true to level sand slopes as directed.

The floor shall be kept wet for a minimum period of 7 days so that bedding and joints set properly.

Polishing shall be normally commenced after 14 days of laying the stone slab. First polishing shall be done with carborundum stones of 120 grade grit fitted in the heavy machine and then second polishing shall be done with carborundum stone of 220 to 350 grade grit fitted in heavy machine. Water shall be properly used during polishing. The stone shall then be washed clean with water. When directed by the Engineer-in-charge; wax polish of approved quality shall be applied on the surface with the help of soft cloth over a clean and dry surface. Then the polishing machine fitted with bobs shall be run over it.

The holes required for Nahni traps, pipes and other fittings shall be made without any extra cost.

Mode of measurements & payment

The rate shall include the cost of all materials and labour involved in all the operations described above. The granite stone flooring shall be measured in square meters correct to two places of decimal, length and breadth shall be measured correct to a centimeter and between the finished face of skirting dedo or wall plaster and no deduction shall be made nor extra paid for any opening in floor of areas upto 0.1sq.mt.

Item No.30 Schedule B1 & Item No.29 Schedule B2 & Item No.35 Schedule B3:

Glazed Stoneware ISI pipe supply, laying, jointing, fixing work of pipes required. Specials jointing materials, lighting, all

necessary safety arrangements and necessary testing to be done. (Excluding excavation, bedding and refilling) with supply and fixing–150 mm dia

TECHNICAL SPECIFICATION FOR S & S STONEWARE GLAZED PIPE.

All the specifications mentioned in the I.S Code 651-1992 & its latest revised addition shall be strictly followed.

In the revision of the above said code, grading based on Hydraulic test has been deleted and the standard monogram has also been modified and it appears as ISI symbol with IS: 651.

Tests for Acid & Alkali resistance for pipes and fittings which were earlier optional have now been made mandatory.

GLAZED STONEWARE PIPES AND FITTINGS:

This standard covers dimensions and performance requirements for the following glazed stoneware pipes and fittings:

- a) Straight pipes and taper pipes
- b) Bends
- c) Taper bend
- d) junctions
- e) half section channels, straight and taper
- f) channel junctions
- g) channel bends
- h) channel interceptors
- i) gully traps, and
- j) inspection pipes

The pipes as covered in this standard are not meant for potable water applications.

Dimensions of glazed stoneware pipes and fittings are grouped into two sections, A & B. Section-A covers dimensions of straight pipes and all such fittings which normally form part of pipeline and which are subject to same conditions, specifications and tests as straight pipes. Section-B includes dimensions of fittings which are commonly used but do not form a part of the normal pipe line. The fittings in section-B being hand-moulded articles, their conformity to dimensional specifications is not required to be so accurate as for those in Section-A.

REFERENCES:

The following Indian Standards are the necessary adjunct to this standard.

IS No	Title
808:1989	Dimensions for hot rolled steel beam, column, channel and angle section (third revision)
2730:1977	Magnesium sulphate (Epsom salt)(first revision)
2781:19/5	Glossary of terms relating to ceramic ware(first revision)
4905:1968	Method for random sampling

1.1.6. TERMINOLOGY:

For the purpose of this standard, the definitions of terms given in IS 2781 : 1975 shall apply.

RIGHT-HAND AND LEFT-HAND FITTINGS:

A right-hand fitting is such that when viewed from the spigot towards the socket, the arm of a junction or the socket of a bend projects to the right (See Fig.1A and 1B). a left-hand fitting is such that when viewed as above, the arm of socket projects to the left.

RIGHT-HAND FITTINGS

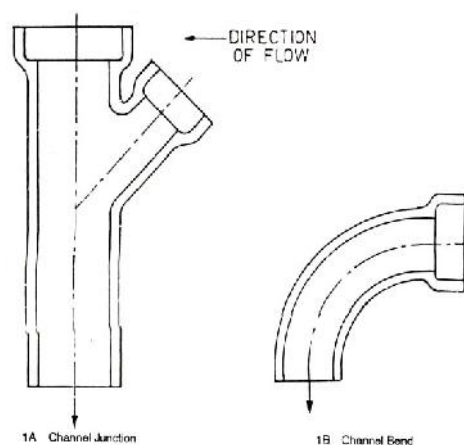

GENERAL QUALITY:

All pipes and fittings shall be sound and free from visible defects which impair the strength, durability and serviceability. The glazed of pipes and fittings shall give a sharp clear note when struck with a light hammer

For pipes and fittings, a maximum of 10 percent shall be acceptable with any one of the following blemishes which do not impair the strength, durability and serviceability provided these pipes and fittings satisfactorily pass the hydraulic test specified in 4.1.10.2.

- a) A thin chipping not exceeding one quarter of the thickness of the body and not exceeding 10 cm^2 on the outside of spigot or on either side of the socket.
- b) One blister, unbroken, not more than 3 mm high not more than 40 mm in largest dimension inside or outside of the pipe; and
- c) Hair line surface cracks. Colour of pipes / fittings may vary from yellow to dark brown / black.

GLAZING:

The interior and exterior surfaces of the pipes and fittings which remain exposed after jointing shall be glazed. The portion which remains covered after jointing may or may not be glazed. The glaze shall be obtained by the action of fumes of volatilized common salt on the material of the pipes and fittings during the process of burning or glazed shall be ceramic glaze consisting of glazing material applied prior to fixing.

TESTS:

Testing Facilities:

The manufacturer shall at his premises and at his own cost, provide the necessary gauges, supply and prepare all test pieces and supply all labour and apparatus for testing which may be necessary for carrying out the tests as required by this standard.

Hydraulic Test:

When subjected to the hydraulic test straight pipes shall with stand the internal hydraulic test pressure of 0.15 MPa ($1 \text{ MPa} = 10.2 \text{ kg/cm}^2$) on the barrels and fittings covered in Section-A and 0.075 MPa for fittings covered in Section-B without showing signs of injury or leakage. The pressure shall be applied on pipes and fittings at a rate not exceeding 0.075 MPa in 5 seconds, and full pressure shall be maintained for atleast 5 seconds. Care shall be taken to ensure that all air is expelled before the test is commenced.

Absorption Test:

The test pieces for testing shall be taken from the body of the pipe or fittings but not from within 150 mm of the end.

Each test pieces shall be of the whole thickness of the wall of the pipe or fittings and shall have two glazed surfaces each having an area of not less than 50 cm^2 and not more than 130 cm^2 . The test pieces shall be cleaned by wire brush to dislodge any loose particles which may increase loss of mass during boiling. The test

piece shall be dried at a temperature of not less than 150°C until no further loss of mass is noted and cooled in a desiccator to the room temperature and the specimen weighed to an accuracy of 0.1 g. The test piece may be suitably suspended in cold distilled water by means of thread so that the test piece may not strike against each other or the container and incur loss in mass and the water in the container shall then be brought to the boiling point. The water shall be maintained at that temperature for 1 hour and after it has been allowed to cool to room temperature, the test pieces shall be removed carefully wiped with a dry cloth and then the mass determined. The percentage increase in mass of each test piece by absorption of water shall not exceed the following values:

Thickness of pipe or fitting mm	Increase in Mass percent
Upto and including 20	6
Over 20 and upto 25	7
Over 25 and upto 32	8
Over 32 and upto 38	9
Over 38	10

Test for Acid Resistance:

Pipes and fittings shall be tested for acid resistance in accordance with the procedure given in Annexure-A. The loss in mass shall not exceed 2.5%.

Test for Alkali Resistance:

Pipes and fittings shall be tested to the action of magnesium sulphate in accordance with the procedure given in Annexure-B. There shall be no evidence of pitting, softening, spalling or cracking in the pipe or fitting after the test.

Crushing Strength Test:

When tested along the full length of the pipe barrel from shoulder to spigot in accordance with Annex. C, the pipe tested shall have a minimum crushing strength of 16 k N/m length.

SAMPLING AND CRITERIA FOR CONFORMITY:

The scale of sampling and the criteria for conformity of a lot shall be as prescribed in Annexure-D.

MARKING:

Every pipe and fitting shall have legibly impressed upon it before firing the following:

- a) Name or trade-mark of the manufacturer, and
- b) Size (Internal Dia.)

Each pipe and fitting may also be marked with the Standard Mark.

SECTION-A PIPES AND FITTINGS FORMING PART OF PIPELINE

INTERNAL DIAMETER:

The internal diameter of the barrels of straight pipes, junction sand bends shall be as specified in col 1 of Table-1.

Permissible Tolerances:

The internal diameters specified in 4.1.13.1 shall be within the following tolerances:

Internal diameter of pipes mm	Permissible Tolerance mm
100	±
150	±
200,230	±
250to350	±
400,450	±
500,600	±

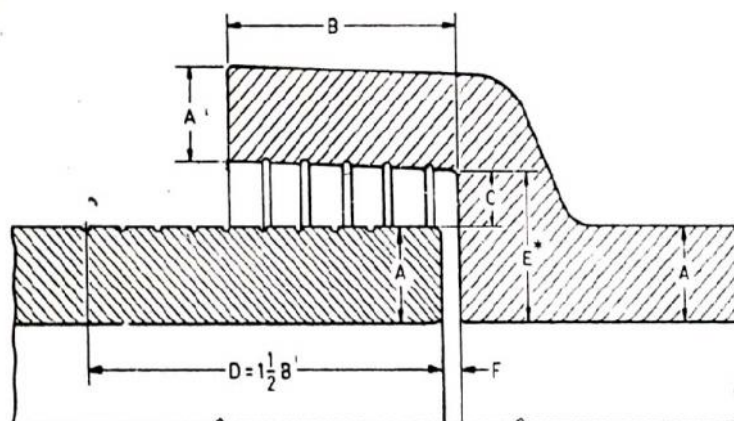

Table-1 Dimensions of Barrels and Sockets
(Clauses 1.1.13.1, 1.1.13.2, 1.1.14.1, 1.1.16.1)

(All Dimensions In Milli meters)

Internal Diameter	Mean Thickness of Barrel and Socket Min A	a) Internal Depth of Socket, Min B	Excess shouldr Measurement Min C	Length of Grooving of Spigot, Min
1	2	3	4	5
100	12	50	10	75
150	15	57	11	85.5
200	16	63	12	94.5
230+	19	63	12	94.5
250	20	70	16	105
300	25	70	16	105
350	30	75	16	112.5
400	35	75	16	112.5
450	37	76	16	14
500	40	80	19	120
600	43	90	19	135

- E = width of shoulder of socket which shall exceed the mean thickness of the barrel of the pipe (ascertained as directed in 4.1.14.1) by not less than the values for C given in col 4. +This is non-preferred size and has been included to facilitate replacements.

1.1.13.3 The pipes shall be inspected by Third Party Inspection Agency, the cost of which is to be borne by contractor. The Third Party Inspection Agency will be from any Government undertaking agency like RITES, EIL, CEIL, MACON, WAPCOS, SGS etc approved by Gujarat Water Supply & Sewerage Board..

THICKNESS OF BARRELS, SOCKETS AND BENDS:

The mean thickness of the barrel and the socket of the pipes junctions and bends shall not be less than the means thickness given in col 2 of Table 1. Such mean thickness of the barrels or sockets of any individual pipe junctions and bends shall be ascertained by making several minimum 4 measurements and adding the measured minimum thickness (not in the groove) to the maximum thickness and dividing the sum by two. The mean thickness of the barrel and socket shall be determined separately.

1.1.14.2. Permissible Variation:

The difference between the minimum and maximum measured thicknesses mentioned in 4.1.14.1 shall not exceed the amounts given below:

Internal diameter of pipe (in mm)	Permissible variation in Thickness of Barrel and Sockets (in mm)
Not exceeding 450	2
500 and 600	3

ANNEX-A (Clause-1.1.10.4.)
TEST FOR RESISTANCE TO ACIDS

PRINCIPLE:

The test specimen is completely immersed in the test solution and the resistance to acid is determined as the percentage of acid soluble matter expressed as sulphate.

REAGENTS:

A-1.1 Sulphuric Acid-4.90percent,specify gravity 1.84.

PREPARATION OF TEST SPECIMEN:

A-2.1 Test specimen shall be sound with all edges freshly broken, free from cracks Or shattered edges, about 5 cm square, not more than 200 g in mass, and shall be thoroughly cleaned with wire brush.

WEIGHING APPARATUS:

A-3.1 The weighing shall be made on a balance accurate to 0.01 g when loaded with 200 g.

PROCEDURE:

A-4.1 The specimens to be tested shall be dried to a constant mass(M1) at a temperature not less than 150oC. The specimens upon reaching constant mass shall be completely immersed in the test solution at the ambient temperature for a period of 48 hours. Then removed from the solution and carefully and thoroughly washed with hot distilled water, allowing the wash to run into the solution in which specimens were immersed. The solution shall be filtered and to the filtrate shall be added 5 ml of concentrated sulphuric acid. The solution shall then be evaporated (avoiding loss by ignition) and heated cautiously to dryness. It shall then be ignited to constant mass (M2)

CALCULATION:

A-5.1 The percentage of acid soluble matter, expressed as sulphate shall be calculated as follows:

$$\text{Loss in mass\%} = \frac{\text{Mass of residue (M}_2\text{)}}{\text{Mass of dry specimen (M}_1\text{)}} \times 100$$

ANNEX-B
(Clause-1.1.10.5.)
TEST FOR ALKALI RESISTANCE

PRINCIPLE:

B-0.1 The resistance of stoneware pipes or fittings to alkali is determined by reaching it with magnesium sulphate solution.

PREPARATION OF SAMPLE:

B-1.1 Test samples measuring not less than 75cm² and not more than 130 cm² shall be broken from the pipe or fittings. The samples shall be sound, free from cracks or surface defects.

REAGENTS:

B-2.1 Saturated Solution of Magnesium Sulphate- Conforming to IS: 2730:1977.

PROCEDURE:

Heat the magnesium sulphate solution (specific gravity 1.295 to 1.308) to the boiling temperature. Place the test sample in a wire basket and submerge it into the boiling solution; continue heating for two hours. then remove the sample and bring it to a constant mass in a drier or oven at a temperature not less than 110oC. Subject to the test sample to at least five cycles using fresh solution for each cycle. After the completion of five cycles removethe sample from the solution, wash it and bring it to constant mass in a drier or oven at a temperature not less than 110oC. Air cool the sample and observe.

There shall be no evidence of pitting, softening, spalling or cracking.

ANNEX-C (Clause-4.1.10.6.)
CRUSHING STRENGTH TEST

CRUSHING STRENGTH TESTING MACHINE:

C-1.1. While the pipe to be tested is supported in a horizontal position on two bearings parallel to its axis, the load shall be applied to it along the length of the barrel through a third bearing on top of the barrel (see Fig below).

CRUSHING TEST RIG

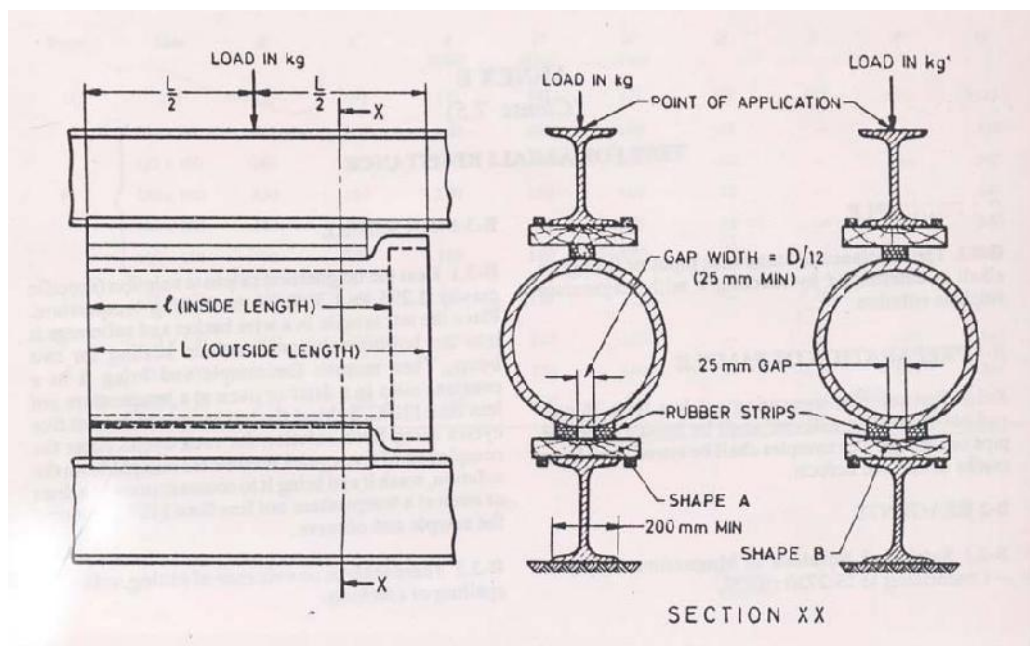

C-1.2 Any testing machine having a device that will apply the load at a uniform rate of about 30 (kN/m) min. or in increments of not more than 500 N at the same rate, may be used for making the test.

C-1.3 The testing machine shall be substantial and rigid throughout, so that the distribution of the load will not be affected appreciably by the deformation or yielding of any part. The bearings shall be as specified in C-1.4, C-1.5, C-1.6 and C-2.1, and shall be attached to the machine so as to receive and uniformly transmit maximum loads required in the tests without lost motion, vibrations, or sudden shock. The machine and bearings shall be designed to transmit the load in a vertical plane through the longitudinal center lines of the bearings and pipe.

C-1.4 The three bearings shall consist of a lower member, being a rigid beam on which two bearing strips are symmetrically disposed parallel to a vertical plane passing through the longitudinal axis of the pipe, and an upper member also being a rigid beam, on which one bearing strip is centred and disposed so that it lies in the vertical plane passing through the

longitudinal axis of the pipe (See Fig. Crushing Test Rig).

- C-1.5 The beam on which the bearing strips are disposed shall be structural steel beams single or of compound sections having moments of inertia about the vertical and horizontal axis of the cross section not less than those of WB 250 (See IS 808 : 1989) and with a width of flange not less than 200 mm.
- C-1.6 Mild steel, teak or similar hardwood shall be used to face the upper flange of the bottom beam. The facing shall be straight and free of warping or twisting and shall be centrally located on the flange of the beam by means of hardwood strips attached to its lower face and in contact with the edges of the flange. The cross section of the facing may have either of two shapes at the discretion of the pipe manufacturer.

Shape A shall be rectangular 280 x 25mm minimum, without a joint. Shape B is shown in (Fig. DETAILS OF ALTERNATIVE FACING).

A similar facing of shape A may be used to face the lower flange of the upper beam if desired.

DETAILS OF ALTERNATIVE FACING

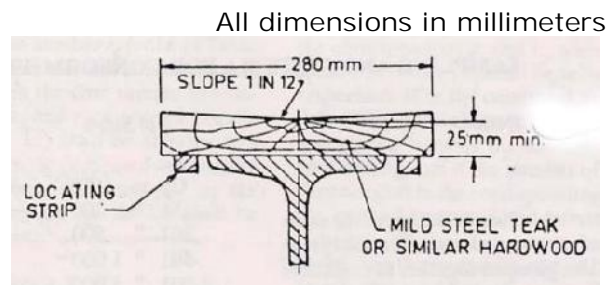

BEARING STRIPS:

- C-2.1 The bearing strips shall consist of rubber cut or formed from material having sufficient hardness. The strips shall be of rectangular cross section having a width of 50 mm and a thickness of not less than 25 mm or more than 40 mm. The two bottom strips shall be of equal thickness.
- C-2.2 The single top bearing strip shall be used with the 50mm dimension in contact with the pipe. It may be positioned on the bearing by the use of wood or metal strips along its outside edges, provided the thickness of the positioning strips does not exceed one-half the thickness of the rubber bearing strip.
- C-2.3 The two lower bearing strips shall be laid on the 50mm dimension and may be positioned on the bearing with wood or metal strips between the mand adjacent to their outside edges, provided the thickness of these positioning strips does not exceed one-half the thickness of these rubber bearing strips.

The two strips shall be parallel and, when used with a facing of Shape A shall be spaced a distance apart of approximately 1 mm per 12 mm of pipe diameter but in no case has than 25 mm. When used with Shape B they shall be parallel and 25 mm apart for all pipe diameters.

- C-2.4 The rubber bearing strips may be attached to the facings, or in the case of the single upper strip, directly to the upper beam, by adhesive if desired, provided, such method of attachment results in the strip remaining firmly fixed in position when carrying the maximum load.

APPLICATION OF LOAD:

- C-3.1 The load shall be applied to the top bearing at a point distant from the spigot and of the pipe equal to one-half of the overall length of the pipe including the socket if any. The test load shall be applied to the top bearing in such a way that the bearing is free to rotate in vertical plane through the longitudinal center line, of the top and bottom bearings. In testing a pipe that is not straight it shall be placed between the bearings in the position that appears to give the most favourable bearing conditions for fair test.

- C-3.2 The loading of the pipe shall be a continuous operation, and the pipe shall not be allowed to stand under load longer than is required to apply the load and record the observations.

EVALUATION OF CRUSHING STRENGTH:

- C-4.1 The ultimate crushing strength in kN per linear metre shall be calculated by dividing the total applied load at fracture by the inside length of the barrel of the sample broken

ANNEX-D (Clause-1.1.11.1) SAMPLING AND
CRITERIA FOR CONFORMITY

D-1 SCALE OF SAMPLING: D.1 Lot:

All the pipes or fittings of the same type, size and manufactured under similar conditions of production, shall be grouped together to constitute a lot.

The number of pipes or fittings to be selected at random from the lot depends upon the size of the lot and shall be in accordance with col 1 to 4 of Table 2.

NUMBER OF TESTS:

All the pipes or fittings selected as in D.2 shall be inspected for general quality (See 1.1.8.), dimensions (See Section A or Section B).

D.3.2. The number of pipes or fittings to be tested for hydraulic test (See 1.1.10.2.) shall be 5% of the lot as prescribed in D1. These pipes may be selected at random from those already selected in D.2 and suitable test specimens.

D.3.3 The number of pipes of fittings to be tested for absorption(1.1.10.3.) for resistance to action of acids (1.1.10.4.) and of alkali (See 1.1.10.5) and crushing strength (See 1.1.10.6.) shall be as given below:

Lot size	No. of pipes to be tested
Upto150	3
151to1200	5
1201to10,000	8

These pipes may be selected at random from those already selected in D.2 and suitable test specimens shall be selected from them.

CRITERIA FOR CONFORMITY:

A lot shall be considered as conforming to the requirements of the specifications, if the conditions mentioned in D.4.2 to D.4.6 are all satisfied.

D.4.2. General Quality (See 1.1.8.) and Dimensions (See Section A and Section B). The number of pipes and fittings in the first sample (See Col 2 and 3 of Table-2) shall be first selected and subjected to inspection for general quality and dimensions. If in the first sample the number of defectives, that is those failing either for general quality or dimensions, is less than or equal to the corresponding acceptance number a_c (col 5 of Table-2), the lot shall be considered as conforming to the requirements of general quality and dimensions. If the number of defectives in the first sample is greater than or equal to the corresponding rejection number r_c (col 6 of Table-2), the lot shall be considered as not conforming. If the number of defectives in the first sample lies between the corresponding a_c and r_c a second sample (see col 2 and 3 of Table-2) shall be selected and subjected to inspection. If in the combined sample, the number of defectives is greater than or equal to the corresponding rejection number r_c the lot shall be considered as not conforming.

Table-2: Sample Size and Criteria for Conformity (Clause D.2)

Lot size	Sample	Sample Size	Cumulative sample size	General Quality(See4.1.8) and dimensions Section a & B)	
				5	6
1	2	3	4		
Upto150	First	20	20	1	4
	Second	20	40	4	5
151 to 280	First	32	32	2	5
	Second	32	64	6	7
281 to 500	First	50	50	3	7
	Second	50	100	8	9
500 to 1200	First	80	80	5	9
	Second	80	160	12	13
1201 to 3200	First	125	125	7	11
	Second	125	250	18	19
3201 to 10,000	First	200	200	11	16
	Second	200	400	26	27

For the hydraulic test, all the specimens shall satisfy the requirements as specified in 1.1.10.2.

For water absorption test, the mean and range(difference between the highest and the lowest value) of the test results obtained shall be calculated and (mean + 0.6 range) shall be less than or equal to the maximum limit specified in 1.1.10.3.

D.4.5. For resistance to action of acid sand of alkali shall satisfy the requirements specified in 1.1.10.4. and 1.1.10.5. respectively.

D.4.6 For crushing strength test all the test specimen shall satisfy the requirement as specified in 1.1.10.6.

The rate shall be for a unit of one running meter basis.

Item No.31 Schedule B1& Item No.30 Schedule B2& Item No.36 Schedule B3:

Providing and constructing house connection chambers as per type design in brick masonry in C.M. 1:4 and inside plastering in C.M. 1:3 necessary coping in C.C. M-250,PCC in M-10 and fixing of RCC frame and cover (But excluding supply of frame and covers) over house connection chambers etc., complete as per the stipulation in the type design complete.

The said drainage manhole as per drainage type design is to be carried out in brick masonry in CM 1:4 and CC in foundation in 1:3:6 including bedding, benching in 1:2:4 and the inside plaster work in niru finishing in CM1:3as per drainage drawing is to be carried out where as the outer plaster in CM 1:3is to be done with necessary fixing of HDPE reinforced plastic steps of size 385x165x0.25mm as per given type design is to be done. Precast RCC manhole frame and cover is

to be done 1:1.5:3 by filling coping and fixing work. The work shall be such that there shall not be no leakage in the manhole, in which, the rate for excavation shall be paid separately which is not included the prescribed rate. The frame and cover shall be provided by RMC Store and same shall have to be transported from Store to Site at the cost of contractor and fixing work is to be carried out accordingly, for which, the rate for only fixing work shall be paid.

The rate for manhole shall be for one number in which, the rate for frame and cover shall be paid separately where for additional depth, the rate shall be paid on one running meter basis as shown in Schedule of this tender.

THE MANHOLE AND DEPTH OF MANHOLES:-

The manholes on the sewers shall be constructed in the form and of the dimensions shown in the Drawing. The depth of the manholes shall be measured from the top of cover to the invert level of the manhole.

The manholes shall be constructed at places shown on the drawings or whatever directed by the Engineer. Type designs for these manholes are shown on the drawings but the actual type and dimensions shall in each case be determined by the Engineer as the circumstances may require. (Refer drawing No. R.M.C-DRN - PHASE-III- 01 to 09)

CONSTRUCTION OF BRICK MASONRY MANHOLES:

The brick masonry shall be constructed as per the type design shown in the drawing enclosed. The various types of manholes to be adopted as per the requirement have been indicated in the L-section and sewer layout drawing in general. The manhole will be fitted with R.C.C. pre-cast medium or heavy duty manhole frame and cover as the case may be. The brick masonry manhole shall be plastered from inside and outside as shown in the drawing and as shown CM proportion and thickness.

FLOORS AND 0.80 ID CHANNEL PIPES:

The floor shall consist of cement concrete. Concrete of R.C. 0.80 ID channel pipes of the required size and curves shall be laid and bedded in cement on the concrete base to the same lines and fall as sewers unless otherwise directed. Both sides of the channel pipes shall be trenched up in concrete and rendered in cement mortar 20mm thick and formed to a slope of not less than 1 in 12 to the channel.

STEPS:

Where the depth of the invert exceeds 0.90M below the surface of the ground, HDPE reinforced steps of approved pattern shall be provided as per type design shown in manhole drawings.

RATE OF MANHOLES:

The rate for construction of manhole to be quoted in the bill of quantities shall include complete masonry, structure, concrete cap, plastering with cement from inside and outside, bottom concrete or channels including providing and fixing of HDPE reinforced steps and fixing of R.C.C. manhole frame & covers complete as per type design drawing and cutting the pipes flush with the inside plaster of the wall. The manholes will be paid per numbers up to the minimum depth shown in the type design and for depth beyond the specified minimum depth for a particular type of manhole, extra will be paid per running meter depth. The rates

includes dewatering during all stages of construction.

The brick masonry will be paid per number excluding excavation but including masonry, bottom concrete, plastering, benching channel fixing of RCC frame and covers. (Refer R.M.C. DRG for H.C.1, H.C.2)

The rate for a unit of one number.

Item No.32 Schedule B1& ItemNo.31 Schedule B2& Item No.37 Schedule B3:
Precast RCC Circular Frame and cover of 5 and 10 Ton capacity round of 600 mm dia.

SHAPES AND DIMENSIONS

Shapes

The percent concrete manhole covers and frames shall be of any shape given.

Dimensions And Tolerances

The dimensions and tolerances on dimensions of frames shall be as shown in Table-1 but outside dimensions of cover at top shall match with the corresponding frame so that the maximum clearance at bottom between the frame and the cover all round the periphery is not more than 5mm and the top surface of the frame and cover is in level within a tolerance of ± 5 mm.

For facility of removing the cover from the frame, suitable taper matching with taper given for the frame shall be provided to the periphery of the cover (See Fig.1).

Fig.1-Typical Illustration of Circular Precast Concrete Manhole Cover
(All dimensions in millimeters)

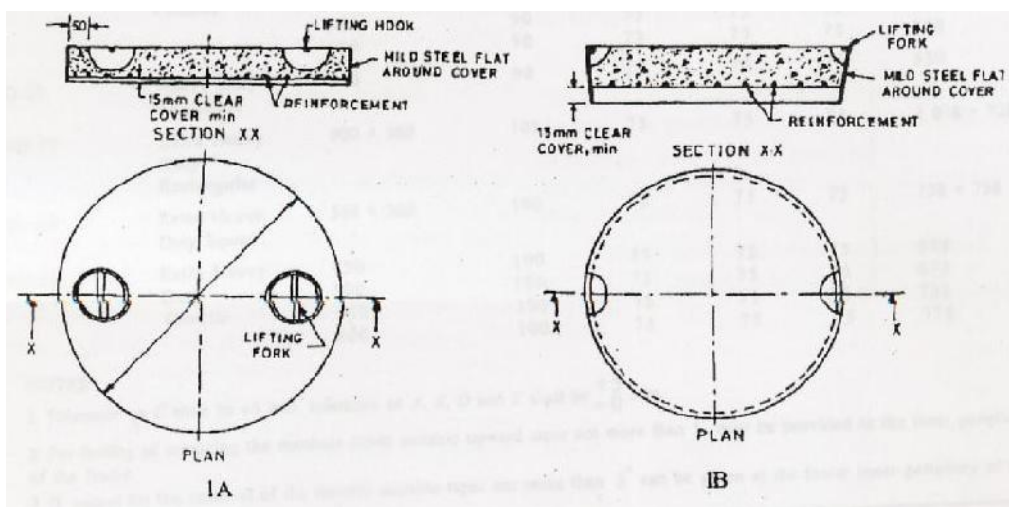

12.0 DESIGN:

The reinforced concrete manhole cover and frame shall be designed in accordance with the provisions of IS 456. If required by the purchaser, the manufacturer shall furnish the specification and drawings principle given in IS 456 may be followed.

MD-10	Medium Duty	500	70	50	50	50	620
-------	-------------	-----	----	----	----	----	-----

	Circular						
--	----------	--	--	--	--	--	--

LIFTING HOOKS:

The minimum diameter of mild steel rod used as lifting device shall be 12 mm for light and medium duty covers and 16mm for heavy and extra heavy duty covers. The lifting device shall be protected from corrosion by hot dip galvanizing or any other suitable means approved by the purchaser or shall be made of naturally corrosion resistant metal rods.

The lifting arrangement shall be as agreed between the manufacturer and the purchaser. Typical arrangements of lifting devices are shown in Fig.1A and 1B.

PHYSICAL REQUIREMENTS:

General

All the covers and frames shall be sound and free from cracks and other defects which interferes with the proper placing of the unit or impair the strength or performance of the units. Minor chippings resulting from the customary method of handling and transportation shall not be deemed ground for rejection.

Dimensions

The dimensions of the cover and frame shall be as specified in 11.0; the overall dimensions of the units shall be measured in accordance with Annexure-B.

Load Test

The breaking load of individual units when tested in accordance with the method described in Annex-C shall be not less than the values specified in Table-2. Also, the permanent set shall not exceed the requirement given in Annexure-C.

Table-2-Test Load and Diameter of Block
(Clause 15.3, 18.3 and C.1.1)

Grade of Cover	Type	Load kN	Diameter of Block mm
1	2	3	4
MD-10	Rectangular , or Circular	100	300

The rate shall be for a unit of one cover and one frame each number.

Item No.32 Schedule B2:

Fixing teakwood frame & 18mm plywood shutters on existing selves, 0.8mm lamination innerside, Alluminium fittings, stoper,lock, paint complete

The shutters with 18 mm plywood with Teakwood frame for shutters is to be provided and fixed with approved quality material as instructed. 0.8 mm white lamination inner side is to be fixed of approved quality sunmica with hinges, stopper, etc. Both side lamination for selves for 18 mm thick ply is to be done. The Plywood brand shall be Kitply, Century, Dura, Everest.. Alluminium fittings, stopper lock etc. including wih labour.

The work as per instruction by the Engineer-in-charge shall have to be completed

The rate shall be for a unit of one square meter basis.

Item No.23 Schedule B1& Item No.33 Schedule B2& Item No.39 Schedule B3.:

European type w/c with sit, cover fixing with comp. standard quality.

1.0 Materials:

- 1.1 The European Water Closet shall consist of a Wash down closet in white glazed or coloured earthenware with integral "P" or "S" trap as specified.
- b. Rubber joints for inlet connection.
- c. Black or any other colour of solid plastic seat and cover with chromium plated hinges and rubber buffers as specified

2.0 Workmanship

2.1. The pan shall be sunk into the floor and embedded in a cushion of average 15cm. cement concrete 1:5:10 (1 cement: 5 fine sand: 10 graded stone aggregate or brick aggregate 40 mm. nominal size) or as specified. This concrete shall be left 15 mm below the top level of the pan so as to allow for flooring and its bed concrete.

The floor should be suitably sloped so that the waste water is drained into the pan. The pan shall be provided with 100 mm. 'P' or 'S' traps with approximately 50 mm. seal. The joints between the pan and the trap shall be made leak-proof with cement mortar 1: 1 (1 cement: 1 fine sand).

2.2 The whole work is to be carried out necessary supply, fixing etc of required size, shape, color, as per the instructions and to the satisfaction of engineer in charge

3.0. Mode of measurements & payment

3.1. The rate shall include the cost of all materials and labours involved in the operations described under workmanship.

3.2. The 'P' or 'S' trap shall include and not be paid separately.

3.3. The unit rate for the item shall be for a unit of one Nos.

Item No.25 Schedule B1& Item No.34 Schedule B2& Item No.40 Schedule B3:

White porcelain Kitchen sink 600/450/200mm with supply & fixing & White porcelain washbasin 560/410mm Indian make C.I. bracket with fitting chromium plated topes 25cm plastic waste pipe and 12mm pillar cock with comp.

1.0: Materials:

- 1.1. The white glazed earthenware Kitchen sink of 600mm x 450mm x 200mm and washbasin shall be 560mm.x410mm. of 1st quality and make as approved by the Engineer-in charge. The washbasin shall conform to M-59.

2.0: Workmanship:

The washbasin shall be fixed on the wall as and where directed. The washbasin shall be supported on a pair of R.S. or C.I. brackets fixed in C.M. 1:3. (1 cement : 3 sand). The bracket shall conform to I.S. : latest edition. The wall plaster on the rear shall be cut to rest the top edge of the wash basin. After fixing the basin, plaster shall be

made good and surface finished to match with the existing one.:
The bracket shall be painted white with ready-mixed paint.

The C.I. brass trap and union shall be connected to 32 mm.dia. waste pipe which shall be suitably bent towards the wall and which shall charge into an open drain leading to a gully trap. or direct in to the gully-trap on the ground floor and shall be connected to a waste pipe through a floor trap on the upper floors. C.P. brass trap and union may not be provided where the surface drain or a floor trap is placed directly under the basin and the waste is discharged into vertically.

The height of the front edge of the wash basin from the floor level shall be 80cms.

The necessary inlet, outlet connections and fittings such as pillar cocks; CP Grass waste trap waste pipe, stop cock, chain wish rubber plug etc. shall be fixed.

The payment of fittings shall be made separately under separate items.

3.0: Mode of measurements & payment

The rate includes cost of all labour, materials, tools and plant etc. required for satisfactory completion of this item as specified in workmanship.

The rate shall be for a unit of One number.

Item No.35 Schedule B2& Item No.41 Schedule B3: Providing & fixing PVC Nahni trap of 7.6 cm complete

Providing and fixing U-PVC 3.5" thick of prince/supreme/jain make nanhi trap at all floor levels, of the following nominal diameter of self cleaning design with C.I. screwed down or hinged grating including cost of cutting and making good the walls and floors 100 mm. inlet and 50mm outlet etc. complete.

MATERIALS

The U-PVC nahni trap shall conform to M-68-A.

WORKMANSHIP

The nahni trap with 100 mm. dia. Inlet and 50mm. dia. Outlet shall be fixed as per drawings or as directed.

The nahni trap shall be jointed with PVC pipe, 75 mm. dia. with jointing materials as per manufacturer's instruction.

MODE OF MEASUREMENTS & PAYMENTS

The rate includes cost of all labour, materials, tools and plants etc. required for satisfactory completion of this item including lead jointing and testing.

The rate shall be for a unit of one number.

Item No 28 Scheule B1 & Item No 36 Scheule B2 & Item No 42 Scheule B3 :
Brass toper cock Screw down bolt type 15mm dia. fitting with
fixing. & Brass toper cock 15mm dia. fitting with fixing

The Brass Cock Screw down bolt type of 15mm dia is to be provided and all the necessary fitting and fixing with required material as per the instructions of engineer in charge is to be carried out and complete accordingly.

The rate shall be for a unit of one number.

Item No 27 Scheule B1 & Item No.37 Schedule B2 & Item No 43 Scheule B3
Rigid P.V.C. Pipe ISI Marked of 6 kg/sq.cm. Pressure, required with
coupler, only supplies work and fixing for pipe of 110mm. outer
dia.110mm

Material

The low density polythene pipe of specified diameter with 6 Kg/Sq.cm. working pressure shall conform to IS. latest edition. The specials and fittings required shall be of best quality.

Workmanship

The PVC. Pipes of specified diameter shall be fixed as directed Due to thermal expansion of rigid PVC pipes, due allowance shall be made particularly in over ground pipelines for any change in length of pipeline which may occur during installation or when pipeline is in service: Above ground installation of rigid PVC; pipe should be under taken after preparations are observed for their protection against direct sun rays and mechanical damage.

The rigid PVC. pipelines should not be kept exposed above ground when it passes through public places, railway lines, roadside and footpaths.

PVC pipes shall be supported at the following intervals:

20mm.dia.500mm.25mm.dia.750mm.-32mm.dia 900mm:

Close support spacing shall be provided if recommended by the manufacture.

The guide lines indicated by the manufacturer regarding handling, transportation, storing, laying and jointing of pipes shall be kept in view during execution.

PVC pipes shall be fixed on wall with wooden plugs and suitable plastic clamps.

Jointing the pipes:

The pipes and sockets shall be accurately cut. The ends of the pipes and fittings should be absolutely free from dirt and dust. The outside surface of the pipes and the inside of the fittings shall then be roughened with emery paper, and then solvent cement joint. Since solvent, cement is aggressive to PVC care must be taken to avoid applying excessive cement to the inside of pipe sockets as any surplus cement cannot be wiped off after jointing. Empty solvent cement tins, brushes, rags, or paper unpregnated with cement should not be buried in the trenches. They should be gathered not left scattered about, as they can prove to be a hazard to animals ,which may chew them.

If any manufacturer recommends its own methods of jointing the same shall be adopted after necessary approval from the Engineer-in- charge.

Laying pipes in Trenches:

The pipes shall be laid over uniform relatively soft fine grained soil found to be free of presence of hard objects such as large flints, rocky projections; large tree roots etc. The width of the trenches shall be minimum width required for working.

The pipes laid underground shall not be less than one meter from the ground level. The pipe shall be positioned in the trenches so as to avoid any induced stressed due to deflection. Any deviation required shall be obtained by using proper type of rubber ring joints.

Mode of measurements and payment:

The description of each item shall, unless otherwise stated, be held to include where necessary, conveyance, and delivery, handling, unloading, storing, fabrication, hoisting, all labour for finishing to required shape and size, setting, fitting in position, straight, cutting and waste, return of packings etc.

The length shall be measured on running meter basis of finished work. The length shall be taken along the centerline of the pipe and fittings. The pipes fixed to walls, ceiling; floors etc. shall be measured and paid under this item.

All the work shall be measured in decimal system as fixed in its place, subject to tolerance given below unless otherwise stated.

- (i) Dimension shall be measured to the nearest 0.01 metre.
- (ii) Area shall be worked out to the nearest 0.01 sq. meter

All measurements of cutting shall unless otherwise stated be held to include the consequent waste.

In case of fitting of unequal bore, the largest bore shall be measured for the test.

Testing of pipelines, fittings, and joints include for providing all plant and appliances necessary for obtaining access to the work to be tested and carrying out the tests.

The rate includes galvanized steel tubing with screwed socket joints, together with all fittings (such as bends, sockets, springs, elbows, tees, crosses, short pieces, clamps and plugs unions etc.) and fixing complete with clamping wall-hooks, wooden plugs etc. and also cutting, screwing and waste and for making forged (or handmade) bends on piping as required. Connector shall be inserted, where required or directed. The rate also includes cutting through walls, floors etc. and their making good and painting exposed threads with anticorrosive paint as above and testing. Where tubes are to be fixed to wall, ceiling and flooring, the rate shall not include painting of pipes, providing sleeves and sand filling under floor for which separate payment shall be made.

The rate shall be for a unit of One running meter.

Item No.38 & 39 Schedule B2 & Item No 45 & 45 Scheule B3:
uPVC pipes of Shedule-40 of any standard approved brand & quality
Of Dia 15mm & 25mm

Material

The upvc pipe of specified diameter with schedule-40 shall conform to IS. latest edition. The specials and fittings required shall be of best quality.

Jointing the pipes:

The pipes and sockets shall be accurately cut. The ends of the pipes and fittings should be absolutely free from dirt and dust. The outside surface of the pipes and the inside of the fittings shall then be roughened with emery paper, and then solvent cement joint. Since solvent, cement is aggressive to PVC care must be taken to avoid applying excessive cement to the inside of pipe sockets as any surplus cement cannot be wiped off after jointing. Empty solvent cement tins, brushes, rags, or paper unpregnated with cement should not be buried in the trenches. They should be gathered not left scattered about, as they can prove to be a hazard to animals, which may chew them.

If any manufacturer recommends its own methods of jointing the same shall be adopted after necessary approval from the Engineer-in-charge.

Laying pipes in Trenches:

The pipes shall be laid over uniform relatively soft fine grained soil found to be free of presence of hard objects such as large flints, rocky projections; large tree roots etc. The width of the trenches shall be minimum width required for working.

The pipes laid underground shall not be less than one meter from the ground level. The pipe shall be positioned in the trenches so as to avoid any induced stressed due to deflection. Any deviation required shall be obtained by using proper type of rubber ring joints.

Mode of measurements and payment

The description of each item shall, unless otherwise stated, be held to include where necessary, conveyance, and delivery, handling, unloading, storing, fabrication, hoisting, all labour for finishing to required shape and size, setting, fitting in position, straight, cutting and waste, return of packings etc.

The length shall be measured on running meter basis of finished work. The length shall be taken along the centerline of the, pipe and fittings. The pipes fixed to walls, ceiling; floors etc. shall be measured and paid under this item.

All the work shall be measured in decimal system as fixed in its place, subject to tolerance given below unless otherwise stated.

- (iii) Dimensions shall be measured to the nearest 0.01 metre.
- (iv) Area shall be worked out to the nearest 0.01 sq. meter

All measurements of cutting shall unless otherwise stated be held to include the consequent waste.

In case of fitting of unequal bore, the largest bore shall be measured for the test.

Testing of pipe lines, fittings, and joints include for providing all plant and appliances necessary for obtaining access to the work to be tested and carrying out the tests.

The rate includes galvanized steel tubing with screwed socket joints, together with all fittings (such as bends, sockets, springs, elbows, tees, crosses, short pieces, clamps and plugs unions etc.) and fixing complete with clamping wall-hooks, wooden plugs etc. and also cutting, screwing and waste and for making forged (or hand made) bends on piping as required. Connector shall be inserted, where required or directed. The rate also includes cutting through walls, floors etc. and their making good and painting exposed threads with anti corrosive paint as above and testing. Where tubes are to be

fixed to wall, ceiling and flooring, the rate shall not include painting of pipes, providing sleeves and sand filling under floor for which separate payment shall be made.

The rate shall be for a unit of One running meter.

Item No.40 Schedule B2& Item No 46 Scheule B3:

Water Storage Tank of HDPE material cylindrical Vertical Black with closed Top 'SINTEX' Brand. (1000 Liter Capacity).

MATERIALS AND WORKMANSHIP :

Overhead water tanks "Sintex" or equivalent of cylindrical vertical tanks with closed top with of self-supported type having approved grade of polyethylene, molded to seamless and suitable for potable water tank of capacity as mentioned in Schedule-B as per company's dimensions provided with G.I. fittings of size 25mm Dia for inlet, outlet, overflow and scour connections and float valves etc. complete placed with all fittings fixing as directed by engineer in charge.

The rate for this work will be paid per number basis.

Item No 10 Scheule B1 & Item No.41 Shedule B2 & Item No 47 Scheule B3:

Removal of Excavated Stuff within RMC limit as directed by Engineer-in-Charge

Surplus earth shall have to cart by the contractor within specified limit including loading, transporting, unloading, spreading, etc.

The surplus stuff shall be disposed off at the following sites as directed within the prescribed limits of Notification as directed by the engineering in charge.

1. Beside Kotharia Police Station near Stone Quarry
2. All Quarry areas of Raiya Smart City
3. TP Scheme No.10,FP-87,Dhebar Road(South), Atika Area, Nr. PGVCL Office
4. TP Scheme No.23, FP-23, Nr.IOC Godown, Morbi Road
5. TP reservation plot at Samrat industrial Area, Bh.ST Workshop
6. TP Scheme No.9, FP-5, Nr. Raiyadhar Garbage Station
7. TP Scheme No.20, FP-35, Bh. Pradhuman Green
8. TP Scheme No.28 (Mavdi), FP-46/A, Nr. GETCO Circle
9. TP Scheme No.12, FP-38/A and 39/B, Nr. Lijjat Papad, Kothariya National Highway

If the contractor fails to dispose the excavated stuff as specified, penalty will be imposed by Rajkot Municipal Corporation as per the Notification for C&D waste.

The excavated material of black cotton soil should be stacked at the location specified by the engineer in charge.

Mode of Measurement and Payment:

The measurement of excavation in trenches for foundation shall be made according to the sections of trenches shown on the drawing or as per sections given by the engineer-in-charge.

No payment shall be made for surplus excavation made in excess of above requirement or due to stopping and sloping back as found necessary on account of conditions of soil and requirements of safety.

The rate shall be for a unit of one cubic Meter.

Item No.42 Schedule B2 & Item No 48 Scheule B3:

Providing Steel work for RCC work supplying, bending, binding & hooking by binding wire with Thermo Mechanically Treated (TMT) bars confirming to IS 1786, Fe-500

Materials

TMT bars of Fe-500 should be confirming to IS: 1786.

Workmanship

The work shall consist of furnishing and placing reinforcement to the shape and dimensions shown as on the drawings or as directed. Steel shall be clean and free from rust and loose mill scale at the time of fixing in position and subsequent concreting.

Reinforcing steel shall conform accurate to the dimensions given in the bar bending schedules shown on relevant drawings. Bars shall be bent cold to specified shape and dimensions or as directed, using a proper bar bender, operated by hand or power to attain proper radius of bends. Bars shall not be bent or straightened in a manner that will damage the material. Bars bent during transport or, handling shall be straightened before being used on the work. They shall not be heated to facilitate bending. Unless otherwise specified, a 'U' type hook at the end of each bar shall invariably be provided to main reinforcement. The radius of the bend shall not be less than twice the diameter of circle having an equivalent effective area. The hooks shall be suitably encased to prevent any splitting of the concrete.

All the reinforcement bars shall be accurately placed in exact position shown on the drawings, and shall be securely held in position during placing of concrete by annealed binding wire not less than 1 mm in size and by using stay blocks or metal chair spacers, metal hangers, supporting wires or other approved devices at sufficiently close intervals. Bars shall not be allowed to sag between supports nor displaced during concreting or any other operations of the work. All devices used for positioning shall be of non-corrodible material. Wooden and metal supports shall not extend to the surface of concrete, except where shown on drawings. Placing bars on, layers of freshly laid concrete as the work progresses for adjusting bar spacing shall not be allowed. Pieces of broken stone or brick and wooden blocks shall not be used. Layers of bars shall be separated by spacer bars, precast mortar bricks, or their approved devices. Reinforcement after being placed in position shall be maintained in a clean condition until completely embedded in concrete.

Special care shall be exercised to prevent any displacement of reinforcement in concrete already placed: To prevent reinforcement from corrosion, concrete cover shall be provided as indicated on drawings. All the bars protruding from concrete and to which other bars are to be spliced and which are, likely to be exposed for a period exceeding 10 days shall be protected by a thick coat of neat cement

grout.

Bars crossing each other where required shall be secured by binding wire (annealed) of size not less than 1 mm in such a manner that they do not slip; over each other at the time of fixing and concreting:

As far possible, bars of full length shall be used. In case this is not possible. Overlapping of bars shall be done as directed, When practicable, overlapping bars shall not touch each other, but be kept apart by 25 mm. or 1.25 times the maximum size of the coarse aggregate whichever is greater by concrete between them. Where not feasible, overlapping bars shall be bound with annealed wires not less than 1 mm. thick twisted tight. The overlaps shall be staggered for different bars and located at points, along the span where neither shear nor bending moment is maximum.

Whenever indicated on the drawings or desired by the Engineer-in-charge, bars shall be joined by couplings which shall have a cross-section sufficient to transmit the full stresses of bars at the ends of the bars that are joined by coupling shall be upset for sufficient length so that the effective cross section at the base of threads is not less than the normal cross-section of the bar. Threads shall be standard threads: Steel for coupling shall conform to I: S.226 (Latest edition)

When permitted or specified on the drawing's joints of reinforcement bars shall butt-welded so as to transmit their full stresses. Welded joints shall preferably be located at points when steel will not be subject to more than 75 percent of the maximum permissible stresses and welds so staggered that at any one section not more than 20 percent of the rods are welded. Only electric arc welding using a process which excludes air from the molten metal and conforms to any or all other special provisions for the work shall be accepted. Suitable means shall be provided for holding bars securely in position during welding. It shall be ensured that no voids are left in welding and when welding is done in two or, three stages, previous surface shall be cleaned. properly. Ends of the bars shall be cleaned of all loose scale, rust, grease, paint and other foreign matter before welding. Only competent welders shall be employed on the work. The M.S. electrodes used for welding shall conform to I.S. 814 (Latest edition). Welded pieces of reinforcement shall be tested: Specimen shall be taken from the actual site and their number and frequency of test shall be as directed.

Mode of measurements & payment

Reinforcement shall be measured in length including overlaps, separately for different diameters as actually used in the work. Where welding or coupling is resorted to, in place of lap joints, shall be measured for payment as equivalent length of overlap as per design requirement. From the length so measured, the weight of reinforcement shall be calculated in Kgs. Length shall include hooks at the ends. Wastage and annealed steel wire for binding shall not be measured and the cost of these items shall be deemed to be included in the rate for reinforcement.

The rate for reinforcement includes cost of steel binding wires, its carting to work site, cutting, bending; placing, binding and fixing in position as shown on the drawings and as directed, It shall also include all devices for keeping reinforcement in approved position, cost of joining as per approved method and all wastage and spacer bars.

The rate shall be for a unit of One Kg.

Item No.14 Schedule B1& Item No 43 Schedule B2.:

Applying two coats of Birla (White Cement based) or Asian (acrylic lapy putty) or equivalent & two coats of primer of approved brand and manufacture on new wall surface to give an even shade including thoroughly brushing the surface free from mortar dropping and other foreign matter and sand papered smooth.

General:

Scope of work includes cleaning off the entire surface, remove all loose particles, dust, scale, smoke, and grease from the surface, sand the surface with Emery paper 180 and wipe clean, applying 2 coats of white Birla putty.

Material:

Acrylic Putty of Approved Make as above or as per vender list.

Workmanship:

The Putty shall be of approved brand (Asian, Birla or other approved).Plaster filler (Birla, Asian Putty) to be used for filling up uneven surfaces, small cracks and holes etc and it should be done as per the manufacturer's standard guide line. The whole process of putty required 3 times and with 180 emery paper wipe off 2 time and with 320 emery paper wipe off.

Mode of measurement:

All the measurement shall be taken on net surface area actually painted, deduction will be Made from the area for fixtures, grills, ventilation, door, window, gap, elect boxes and Such obstructions not painted, if they are individually more than 0.05 sq.m.

Rate:

Rate is to include for All materials of putty's, sand paper, emery paper etc. with labour required for scaffolding, cleaning off the surfaces, cleaning the site after completion of job, etc. as directed by engineer in charge.

Rate is for the net surface area of Painted surfaces in Square meter.

Item No.9 Schedule B1& Item no-21 Schedule B3:

Supply & Fixing of 60mm M-30 Grade cement concrete rubber mold paving interlocking paving block (Grey colour) after beding of Bhogavo sand in line and CC on the edge in proportion of 1:2:4 with curing etc. Complete & Supply & Fixing of 60mm M-30 Grade cement concrete rubber mold paving interlocking paving block (Grey colour) after beding of Black stone powder in line and CC on the edge in proportion of 1:2:4 with curing etc. Complete

Paver Block Manufacturing facilities

RAJKOT MUNICIPAL CORPORATION, at its discretion shall nominate its representative for inspection of the factory. Party shall co-ordinate and co-operate with representative of RAJKOT MUNICIPAL CORPORATION. The party shall inform the address, telephone numbers and other details of the workshop and the contact person to enable RAJKOT MUNICIPAL CORPORATION depute its representative. The party shall

allow entry to RAJKOT MUNICIPAL CORPORATION representative during all working days and time.

The Paver Block shall be made in factory with following minimum facilities:

Design Mix Concrete:

- (a) All pavers designated by strength shall be treated as design mix concrete. The aggregate and cement shall be measured by weight in an approved weigh batching equipment. Mixing water shall be measured in graduated litre cans. One or more complete bags of cement shall be used for each batch of concrete.
- (b) The contractor shall be responsible for designing mixes of the specified performance to suit the degree of workability and characteristic strength. The mix design shall be finalized before manufacturing of the paver considering a set of suppliers for cement, sand and aggregates. In case of any change of suppliers of cement, sand or aggregates, party should have design mix ready for alternate suppliers.
- (c) The minimum cement content for compacted concrete of pavers shall not be less than 300/350/400 Kg/sq.mtr as per design.
- (d) The maximum water cement ratio for pavers concrete shall not be more than 0.40
- (e) The design mix proportions for each set of raw material suppliers shall be finalized and approved by the authorized lab for the required compressive strength and the lab report with proportions should be available with the vendor at all times for scrutiny and verification purpose.

Paver Block Making Machine:

The machine should be capable of producing high quality Paver Blocks by obtaining high level of compaction by application of hydraulic compaction and also by high intensity vibration to the moulds. The machine should have automatic control panel and shall apply a minimum pressure of 3000 psi and then there shall be automatic cut off of hydraulic circuit without any manual interference. In no case, pavers mould by manual force or by machine without auto cutoff shall be accepted. All pavers shall have uniformity in strength.

Weigh Batching & Mixing Equipment:

- (a) The proportioning of ingredients of concrete per batch of concrete shall be performed by an approved weigh batching machine. Water shall be fed into the mixer from a tank provided with means for adjusting the flow of water so as to supply the quantity determined for concrete as per mix design. Due allowance shall be made for the weight of water carried by aggregates so that actual amount added at the mixer can be reduced as necessary. For this purpose the moisture content of coarse and fine aggregates shall be ascertained as and when required and at other times when alteration of the moisture content may be expected due to new deliverance of aggregates, inclement weather or other reasons.

- (b) Volumetric batching of concrete may be allowed after the design mix is approved by lab after testing, by converting the proportion of concrete from weight to volumetric measurement subject to facilities being made available by the contractor for verifying and monitoring this.
- (c) All necessary equipment such as measuring boxes, devices for determination of moisture and bulking in sand, slump cone, etc. shall be provided by the contractor. Concrete shall be machine mixed until there is a uniform distribution of materials and uniform colour and consistency is achieved and under no circumstances for less than two minutes.

The concrete Mix Design should be followed for each batch of materials.

Curing:

The factory should have well designed curing area to ensure adequate (minimum 14days)curing of paver blocks.

Laboratory:

The factory should have the following:

- (i) Compression testing machine of capacity minimum 200MT
- (ii) Other tools and equipment for testing raw materials and paver blocks.
- (iii) (1) Systematic record of test results of various paver blocks manufactured in the factory.
- (2) Concrete Mix Design for desired grade of concrete used for making of paver blocks.

Raw Materials.

CEMENT

The cement used in the manufacture of high quality precast concrete paving blocks shall be conforming to IS 12269 (53 grade ordinary Portland cement) or IS 8112 (43 grade ordinary Portland cement) or IS 1489 (Part 1) (Portland-pozzolana cement – fly ash based). The minimum cement content in concrete used for making paver blocks should be 380kg/Cum.

AGGREGATES

The fine and coarse aggregates shall consist of naturally occurring crushed or uncrushed materials, which apart from the grading requirements comply with IS 383-1970. The fine aggregates used shall contain a minimum of 25% natural silicon sand. Lime stone aggregates shall not be used.

Aggregates shall contain no more than 3% by weight of clay & shall be free from deleterious salts and contaminants. Zone iv sand shall not be acceptable. Course aggregate shall be 10mm and below.

WATER

The water shall be clean and free from any deleterious matter. It shall meet the requirements stipulated in IS: 456-2000.

OTHER MATERIALS

Any other materials / ingredients used in the concrete shall conform to I.S. Specifications.

PIGMENT: The pigment shall be used only on wearing and top surface and throughout the paver block. The pigment used shall not be more than 10% of weight of cement used in the wearing course layer. However, use of pigment shall in no way alter the required strength of the paver block.

Pigment used for coloring paver blocks shall have durable color. It shall not contain matters detrimental to concrete. The pigment shall not contain Zinc compound. Lead pigment shall not be used.

Pavers Block Characteristics

The interlocking concrete paver tiles should conform to IS 15658 (LATEST). They shall be tested as per the code and have to qualify limits specified by us down below.

The paver tiles should be made of M-30(80mm) design mix concrete in approved size and shape. For acceptance the average of compressive strengths of 8 pavers shall be minimum 30 N/mm^2 (MPa). Any paver in the tested lot shall not have compressive strength less than 30.1MPa. If needed, pavers shall be designed and manufactured on higher side to concrete grade M-30 to meet this requirement without extra cost to RAJKOT MUNICIPAL CORPORATION. Testing shall be done as per relevant clauses of IS-15658(LATEST).

The concrete pavers should have perpendicularities after release from the mould and the same should be retained until the laying.

The surface should be of anti skid and anti glare type.

The paver should have uniform chamfers to facilitate easy drainage of surface runoff.

The concrete mix design should be followed of each batch of materials separately and weigh batching plant is to be used to achieve uniformity in strength and quality.

The pavers shall be manufactured in single layer or more to ensure smooth surface on top and to remove all voids.

The pavers shall be of cement Grey colour without any pigment or colored with pigment or with chemically treated to p surface as specified.

All paver blocks shall be sound and free of cracks or other visual defects, which will interfere with the proper paving of the unit or impair the strength or performance of the pavement constructed with the paver blocks.

The compressive strength requirement of concrete paver block shall be minimum 30 MPa (N/sqmm) for 28 days (Testing as per IS-15658) after applying the correction factor as per IS-15658 (LATEST). (Please refer clause 3.1 also).

Paver Block Dimensions

Thickness	60/80mm
Shape	Regular (Uniform shape with no Hollow or Cracks)
Chamfer	5mm to 7mm along to pedges
Thickness of Wearing Layer	Minimum 6mm(The thickness of the wearing surface shall be measured at several points along the periphery of paver blocks. The arithmetic mean of the lowest two values shall be the minimum thickness of the wearing layer)
Plan Area A _{sp} (Ref.Cl.B-3.3 Annex B,IS-15658(LATEST))	Maximum 0.03m ²
Colour	Natural cement Grey colour without use of any pigment OR colour as specified
Dimensional Tolerance	Tolerances as per IS-15658(LATEST)

Note: All other visual/physical & dimensional acceptance on parameters like aspect ratio, squareness etc to be as per IS-15658(LATEST)

Testing of Paver Blocks 1 FOR 60/80MM PAVER TILES

TEST	SPECIFICATION Average Values
28 day Compressive Strength	Minimum 30MPa(N/Sqmm)
Abrasion Resistance	Maximum 2 mm [i.e. 10 units of 1000 mm ³ per 5000 mm ² reported as per E-5 of Annex E of IS-15658(LATEST)]
Water Absorption	Avg. of 3 units - Maximum 6% by mass(restricted to 7% in individual test units)

Sampling and Testing Procedure strictly As Per IS 15658 (LATEST).

Laying of Paver Blocks

PRIMING

The contractor is required to verify the existing WBM driveway surface and ascertain the CBR value. Accordingly the total subgrade thickness required for achieving the desired CBR value shall be advised to RAJKOT MUNICIPAL CORPORATION within seven days of receipt of call-up. RAJKOT MUNICIPAL CORPORATION shall, through regular vendors arrange to carryout such WBM, wherever required. Before taking over the site, the Paver block laying party is required to verify the stabilization of the surface with CBR values. In case, contractor does not advise the CBR value within seven days, RAJKOT MUNICIPAL CORPORATION shall carryout WBM as per own design, and contractor shall have no claim later particularly to the quality of WBM or sub-grade. It will be the responsibility of the Paver block party to ensure

that the Manholes/Pipeline/Cable trenches/circular drainage system etc. is raised to driveway level using the requisite materials as per instruction of EIC. The areas of potholes / deep depressions at the isolated locations shall be filled up and properly compacted before laying the paver blocks. No extra payment will be made for this purpose. The area of raised manholes shall be included in the measurement of over all area of paver blocks for the purpose of payment.

BEDDING SAND COURSE

The bedding sand shall consist of naturally occurring, clean, well graded sand passing through 4.75mm sieve and suitable to concrete manufacture. The bedding should be from either a single source or blended to achieve the following grading.

IS SIEVE SIZE	% PASSING
9.52mm	100
4.75mm	95-100
2.36mm	80-100
1.18mm	50-100
600microns	25-60
300microns	10-60
150microns	5-15
75microns	0-10

Contractor shall be responsible to ensure that single-sized, gap-graded sands or sands containing an excessive amount of fines or plastic fines are not used. The sand particles should preferably be sharp, not rounded. The sand used for bedding shall be free of any deleterious soluble salts or other contaminants likely to cause efflorescence.

The sand shall be of uniform moisture content, which shall be within 4%- 8%, at the time of spreading and shall be protected against rain when stock piled prior to spreading. Saturated sand shall not be used.

The bedding sand shall be spread loose in a uniform layer as per drawing. The compacted uniform thickness shall be 50mm and within \pm 5mm. Thickness variation shall not be used to correct irregularities in the base course surface.

The spread sand shall be carefully maintained in a loose dry condition and protected against pre-compaction both prior to and following spreading. Any pre-compacted sand left overnight shall be loosened before further laying of paver blocks takes place.

Sand shall be slightly spreading a loose condition to the predetermined depth only slightly ahead of the laying of the paver block. Any depressions in the spread sand exceeding 5mm shall be loosened, raked and respread before laying of paver block.

LAYING OF INTERLOCKING PAVER BLOCK:

Paver block shall be laid in pattern as specified under cl.7 throughout the pavement. Once the laying pattern has been established, it shall continue without interruption over the entire pavement surface.

Cutting of blocks, the use of in fill concrete or discontinuities in laying pattern is not to be permitted in other than approved locations.

Paving units shall be placed on the un compacted sand bed to the nominated laying pattern; care shall be taken to maintain the specified bond throughout the job. The first row shall be located next to an edge restraint. Specially manufactured edge paving units are permitted or edge units may be cut using a power saw, a mechanical or hydraulic guillotine, bolster or the approved cutting machine. No haphazardly broken pavers shall be used.

Paver block shall be placed with the help of spacers to achieve gaps nominally 2 to 3mm wide between adjacent paving joints. No joint shall be less than 2mm nor more than 4 mm. However it is mandatory to use 3.0mm wide spacer while laying paver tiles so as to ensure uniform 3.0mm gap between adjacent pavers. Frequent use of string lines shall be used to check alignment. In this regard, the "laying face" shall be checked at least every two metre as the face proceeds. Should the face become out of alignment, it must be corrected prior to initial compaction and before further laying job is proceeded with.

In each row, all full units shall be laid first. Closure units shall be cut and fitted subsequently. Such closure units shall consist of not less than 25% of a full unit.

To fill spaces between 25mm and 50mm wide, concrete having minimum 1:1:2 cement : sand : coarse aggregate mix and a strength of 40 N/Sq.mm shall be used. Within such the nominal aggregate size shall not exceed one third the smallest dimension of the infill space. For smaller spaces dry packed mortar shall be used.

Except where it is necessary to correct any minor variation occurring in the laying bond, the paver block shall not be hammered into position. Where adjustment of position is necessary care shall be taken to avoid premature compaction of the sand bedding.

INITIAL COMPACTION

After laying the paver block, they shall be compacted to achieve consolidation of the sand bedding and brought to design levels and profiles by not less than two (2) passes of a suitable plate compactor.

The compactor shall be a high-frequency, low amplitude mechanical flat plate vibrator having plate area sufficient to cover a minimum of twelve paving units.

Prior to compaction all debris shall be removed from the surface. Compaction shall proceed as closely as possible following laying and prior to any traffic. Compaction shall not, however, be attempted within one meter of the laying face. Compaction shall continue until lipping has been eliminated between adjoining units. Joints shall then be filled and re compacted as described in Clause 6.5

All work further than one meter from the laying face shall be leftfully compacted at the completion of each day's laying.

Any blocks that are structurally damaged prior to or during compaction shall be immediately removed and replaced.

Sufficient plate compactors shall be available at the paving site for both bedding compaction and joint filling.

JOINT FILLING AND FINAL COMPACTION

As soon as practical after compaction and in any case prior to the termination of work on that day and prior to the acceptance of any traffic, sand for joint filling shall be spread over the pavement.

Joints and shall pass a 2.36mm (No.8) sieve and shall be free of soluble salts or contaminants likely to cause efflorescence. The same shall comply with the following grading limits:

IS SIEVE SIZE	% PASSING
2.36mm	100
1.8mm	90-100
600mm	60-90
300microns	30-60
150microns	15-30
75microns	10-20

The Contractor shall supply a sample of the jointing sand to be used in the contract prior to delivering any such material to site for incorporation into the works. Certificates of test results issued by a recognized testing laboratory confirming that the sand sample conforms to the requirements of this specification shall be submitted prior to supply of total volume required.

The jointings and shall be broomed to fill the joints. Excess sand shall then be removed from the pavement surface and the jointings and shall be compacted with not less than one (1) pass of the plate vibrator and joints refilled with sand to full depth. This procedure shall be repeated until all joints are completely filled with sand. No traffic shall be permitted to use the pavement until all joints have been completely filled with sand and compacted. Both the sand and paver Block shall be dry when sand is spread and broomed into the joints to prevent premature setting of the sand.

The difference in level (lipping) between adjacent units shall not exceed 3mm with not more than 1% in any 3mX3m area exceeding 2mm. Pavement portions which are deformed beyond above limits after final compaction, shall be taken out and relaid to the satisfaction of the Engineer in charge.

UNIFORM INTERLOCKING SPACES

The pavers should have uniform interlocking space of 2mm to 3mm to ensure compacted sand filling after vibration on the paver surface.

SKILLED LABOUR

Skilled labour should be employed for laying blocks to ensure line and level of pavers, desired shape of the surface and adequate compaction of the sand in the joints.

The rubber mold CC Precast interlocking paving block of approved quality 60/80 mm thickness, Grey Color and of M-40 And/Or M-30 Grade with concreting 1:2:4 and design shall be supplied by RMC. The

bedding of **black stone**/ sand of interlocking block shall be done and the interlocking block shall be fixed hard on it in line and level. The contractor shall have to purchase the block of ISI Mark from the market and same shall have to be got approved from Rajkot Municipal Corporation. The rate for this work shall be paid on one square meter basis.

Item No.17 Schedule B1:

Supply & Fixing of Stair Hand Railing and S.S. railing made of 304 grade, 2" top pipe, 16mm 3 pipe, 40x40 bullster JOTUN, INTERPON, AKZONOBEL with all fixture & fastening etc. complete., all material should be with powder coated and approved by engineer-in-charge

Stainless steel railing should be laid commencing from one end and proceed towards the other end. The railing can be placed to different levels or patterns as directed by Engineer in Charge. With the help of gauges, the joint width specification should be checked in the first few running meters, where it should be ensured that the railing alignment is correct. To start with, full railing section should be used; only subsequently, cutting and in filling at edges be permitted. Under no Circumstances should the railing be forced or hammered into the bedding at the stage of lying. For cutting railing, hydraulic or mechanical block cutters, or power saws are used. Cut units of any shape and size less than required should not be used. Supporting brackets made out of S.S sections fixing with anchor fastener only. 15mm thick toughened glass of approved brand, shall be fixed with approved quality & design of film on one side of toughen glass as per the direction of Engineer in charge. The balusters shall be fixed in steps of stair / C.C block masonry at 1500 mm center to center in line & level. Hand rail of 38 mm diameter having 1.5mm wall thickness shall be jointed with baluster by appropriate accessories required of instructed make or as equivalent approved by Engineer-in-charge only. The entire work shall not be executed in loose fashion. If after erection railing found to be damaged due to erection or due to any type of negligence of the agency, the same shall be replaced without any extra cost.

Mode of measurement & payment:

The rate for railing with frame shall include the cost of materials & labour involved to finish the work.

The dimension of the railing shall be measured clear size of in closed position of railing between the two outer edges of the frame.

The payment shall be made on completion of work.

The unit rate for the item shall be for a unit of one Running meter.

Item No.19 Schedule B1:

Repairing of doors & windows

Repairing of doors & windows like salvindh, screw, Hinges, Bidding patti etc as instructed Engineer in charge.

The rate shall be for a unit of one sq. meter.

ItemNo.24 Schedule B1:Supply & Fixing of Orrisa Pan white porselin standard size

MATERIALS:

Orissa type water closet:

The specification of Orissa type white glazed water closet of first quality shall conform to IS: latest edition and relevant specification of Indian type water closet Except that pan will be with the integral squatting pan of size 580x440mm with raised foot rest.

WORKMANSHIP

The pan shall be sunk into the floor and embedded in a cushion of average 15cm cement 1:5:10(1 Cement:5 Fine Sand:10 Graded stone aggregate 40mm. nominal size) or as specified. This concrete shall be left 115mm below the top level of the pan so as to allow for flooring and its bed concrete.The floor should be suitably stopped so that the waste water is drained into the pan. The pan shall be provided with 100 mm 'P' or 'S' traps as specified in with approximately 50mm seal. The joints in the pan and the trap shall be made leak-proof with cement mortar 1:1(1Cement: 1FineSand).

The rate shall be paid for a unit of number basis.

ItemNo.29 Schedule B1:Flushing Valve Cast Iron Cromium Platted push cock or handle type with flushing supply and fixing

MATERIALS

Providing, supplying and fixing of Flushing Valve Cast Iron Cromium Platted push cock or handle type With flushing of approved quality including necessary fittings, fixing as directed by the engineer-in-charge etc complete.

The rate for this work will paid per Number basis

Item No.33 Schedule B1:Providing & fixing 0.60 x 0.60 size tiles & galvenized frame on gypsam board, false ceiling with moulding & designed patta.

- a) For false ceiling
- b) For decorative molding.
- c) 100 mm wide cornices

General :

The item pertains to providing and fixing 0.60 X 0.60 gypsum ceiling as per the pattern shown on drawing or as directed, with all frames and fixtures.

Material:

1. 0.60 X 0.60 gypsam :

The 0.60 X 0.60 gypsum shall be of the calcium sulphate semi-hydrate variety. Its fineness shall be such that when sieved through a sieve of IS sieve designation 3.35 mm for 5 minutes after drying the residue left on it shall be not more than 1% by weight. The average compressive strength of material determined by testing 5 cm cubes after removal from moulds, after 24 hours and drying in an oven at 40 degree C till weight of the cube is constant.

2. Frame :

The frame work shall be of the specified wood & MS flats. In case of sloping roofs wooden battens of suitable section (depending upon the span and load to be carried) shall be firmly fixed as main supports, to the underside of the tie beams of the trusses at required centres by means of bolts and nuts of proper size. In case of flat roofs, the battens shall be securely fixed to the walls and

columns/pillars by holding down bolts and shall be fastened to the slabs above with iron Rajkot Municipal Corporation straps or MS bars of suitable sections and anchored therein. Cross battens of 50 x 40 mm sections at 40 cm centres or so, shall then be fixed at right angles to the main battens. The framework shall be treated with approved wooden preservative before it is covered with ceiling. The underside of the frame work shall be true to planes and slopes.

3. Wooden Strips :

Wooden strips 25 x 6 mm of first class kailwood, (unless otherwise stipulates specifically in the description of the item) shall be fixed to the cross battens, in the parallel or with gaps of 10 mm in between adjacent rows, by means of flat headed (clout) nails. The strips shall be fixed butt jointed and not overlapped. The joints shall be staggered. The minimum length of strips to be used shall be 1.5 m depending upon the length of strips required.

4. Rabbit Wire Mesh :

Rabbit Wire mesh shall then be fixed to the underside of wooden strips and their junctions with the battens with nails at pitch of 15 to 20 cm as ordered by the Engineer- in-Charge. The rabbit wire mesh shall be straight, tight and perfectly true to planes and slopes and without any sagging and shall be slightly below the underside of the laths to allow the plaster to encase the metal round.

Application of 0.60 X 0.60 gypsam :

The 0.60 X 0.60 gypsam will be mixed with water to a workable consistency. 0.60 X 0.60 gypsam shall be applied to the underside of the laths over the rabbit wire mesh in suitable sized panels and finished to a smooth surface by steel trowels. The plaster shall be applied in such a manner that it fully fills the gaps between the laths and the thickness over the laths as specified in the description of the item. The joints shall be finished flush to make the ceiling in one piece. The finished surface shall be smooth and true to plane, slopes or curves as required. The patterns as per drawings or as directed may be provided precasted and shall be fixed to ceiling frame by the brass screw sat the equal intervals.

Finishing :

The exposed side of the 0.60 X 0.60 gypsam cast in situ or precast or readymade boards shall be truly level and plane. The joints shall be truly parallel and/or perpendicular or non visible as per the approved pattern. The ceiling shall be painted with the approved paint.

Item to Include :

Item includes all labour, material, tools and equipment, all taxes, transportation of material, providing 0.60 X 0.60 gypsam of specified thickness, rabbit mesh, wood work, fixing, painting etc. complete including iron work brackets and screws required for fixing the boards to the roof members. The scaffolding and staging required also shall be included in the item. There are some fans in the rooms. The same shall belowered down by providing a distant piece.

Mode of Measurement and Payment :

Length and breadth of superficial area of the finished work shall be measured correct to a cm. Area shall be calculated in square meter correct to two places of decimal. No deduction will be made of openings of areas upto 0.40 square meter nor shall extra payment be made either for any extra material or labour involved in forming such openings. For openings exceeding 0.40 square meter in area, deduction in measurements shall be made but extra will not be payable for any extra material or labour involved in making such openings. Curved surfaces shall be measured and paid for separately from flat surfaces. The work

shall be deemed to comprise of flat surfaces only unless specifically stated otherwise in the description of the item. Any sunk or raised moldings in the plaster shall not be measured and not paid for separately. The contract rate shall be per sqm of the area of the ceiling of 0.60 X 0.60 gypsam including all the lifts.

Item No.22 Schedule B3:

Fixing of CC Precast Road Divider stone 0.38 x 0.30 x 0.20 m including required material and labour (without colour)

If Rajkot Municipal Corporation will provide cement concrete blocks prepared at Departmental Production Unit of Rajkot Municipal Corporation as per specified rate then Above CC Block is to be collected by the agency at their cost and transport it to the required site. No transportation will be paid. If Divider Block is not available in RMC Production Unit then the contractor shall have to purchase the same from the market. Required excavation work shall be carried out by the agency on the paver road or conventional asphalt road as per depth and width as directed by Site Engineer. No extra payment will be made. The excavated stuff shall be disposed off as directed by the site incharge. Lime mortar of 1 part lime and 4 part of sand shall be well mixed and laid in minimum 50 mm thickness and C C precast rubber mould blocks shall be laid as per proper alignment keeping in mind the projection of tiles laying bed in the inner side of the block. Cement mortar of 1:6 is required to be used for 18 mm vatta and aesthetic groove shall be made as directed between the two blocks with proper vatta along with cement paste with required tamping etc complete as directed by Site Engineer. Minimum 75 mm x 75 mm triangular shaped lodhiya shall be casted with 1:2:4 cement concrete on both outer side of the block. The portion between the two blocks below the tile flooring level shall be filled with quality hard murrum and shall be watered for achieving proper compaction as directed and shall be tampered properly.

If Cement concrete blocks shall be purchased from Corporation Departmental Production Unit by deduction from bill amount. If the material is supplied from RMC Store, Rajkot Municipal Corporation will be deduct the amount for such supply as per the current S.O.R. rate of Rajkot Municipal Corporation. Excavated stuff shall be removed and spread within 90m lead as directed and no extra cost will be given.

The required stone shall either be supplied by Store or if required, as and when it is to be purchased from market shall be got approved from RMC. The stone shall be of good in quality if it is purchased from market and of sharpened edge and of sufficient crushing strength as per I.S. The testing shall be carried out at the cost of the bidder

Mode of measurement shall be as per unit of one number.

Item No.23 Schedule B3:

Painting of Traffic Strip footpath/Circle & Dividr block size 0.38x0.30x0.20 mt in two coats using enamel paint in different color

In this work the color work to road divider blocks except flooring including top the portion outside the road (from ground) is to be carried out with the oil paint of approved quality. The shade of various colors shall be used as approved by the engineer-in-charge. The work is to be carried out as per the instructions of engineer-in-charge.

For this color work, first of all primer is to be applied to old road divider blocks thereafter one coat is to be applied for whole work and shall have to be got checked from the engineer-in-charge and thereafter only the second coat is to be applied. The liquid between the two colors shall be done with due care and in line level.

The rate for this work shall be for running meter basis.

Item No.32 Schedule B3 :

Making tabel 0.75 mt. Height, 18mm approved plywood, 1mm laminates, required lock arrangement, sliding drawer, handle etc. fitting fixing complete.

The wooden table shall have to prepared by providing all the required material of approved quality as per the requirement and instructions of engineer in charge. The size of the table shall be 1.37 X 0.75 X 0.75. The plywood requirement and other details for making the table is as under:

Plywood of 18 mm of approved quality and water proof ISI Mark :56.00 Sq. Mt.

Plywood of 12 mm of approved quality and water proof ISI Mark :24.00 Sq. Mt.

Plywood of 6 mm of approved quality and water proof ISI Mark :32.00 Sq. Mt.

Sunmica 1 mm of approved quality 8'X4' size sheet 2 Nos.

Wooden Dhoka for foot rest and front portion of box for placing the Key-Board

Wooden Bidding patti as per requirement of 1"x0.25" of 2"x0.25"

Steel Sliding channel of approved quality and make for drawers: 3 Nos.

Necessary Locks of approved quality: 3 Nos.

S S Handle as per instructions : 3 Nos.

Hinges of approved quality and size : 2 Nos.

Fevicol : 2 Kg

Nails, Screw, Magnet, Agrotape etc. as per requirement

Rickshaw Trip for bringing of materials - 1 Trip

Applying Oil Paint, Polishing, Astar, etc.

For 1 Table including material and labour.

The whole work for preparation of table is to be carried out by providing all above and other necessary materials as may be required to complete the item as per requirement and instructions of engineer in charge to his satisfaction.

The rate will be paid for a unit of one square meter basis.

Item No.28 Schedule B3

White Porselin Urinal with require Plastic waste pipe fitting and fixing

Material:

The urinal shall be of approved quality including connecting the urinal with waste pipe, tap etc. complete of required size, shape, color etc. Complete as per the Instructions of engineer-in-charge.

Mode of measurements & payment

The rate shall be for a unit of One Unit

Item No 26 Schedule B1.:

Providing and fixing Mirror 400 mm. x 300 mm. beveled edge minor of superior glass mounted on 6 mm. thick A.C. Sheet or plywood sheet and fixed to wooden plugs with C.P brass screws and washers.

1.0. Materials

1.1. The 400mm x 300mm size mirrors will be of superior glass with edge rounded offer beveled as specified. It shall be free from flaws specks, or bubble sand its thickness shall to be less than 6mm. The glass for the mirror shall be uniformly silver plated at the back and shall be free from silvering defects Silvering shall have a protective uniform covering of red lead paint. The 6mm thick plywood shall conform to M-37.The 6mm. thick A.C. sheets shall conform to M-24.

2.0. Workmanship

2.1. The mirror of 400mmx300mm.size mounted on A.C. Sheet or plywood 6mmthick with C.P. brass clips shall be fixed as directed, by fixing wooden plugs in wall and C.P brass screw sand washers. The work shall be carried out in best work man like manner.

3.0. Mode of measurements & payment

3.1. The rate includes cost of all labour and materials, tools and plant etc. Required for satisfactory completion of this item.

The rate shall be for a unit of one number.

Addl/Asst. Engineer
R.M.C.

Dy.Ex.Engineer
R.M.C.

ADDL. CITY ENGINEER
R.M.C.

<u>LIST OF APPROVED MAKE (Civil Work)</u>					
NO.	SPACE	PARTICULAR	COMP		
1	Ready mixed Concrete		Lafarge/Bhanu/ultratech/RJ/Krishna		
2	Ordinary Portland Cement (Minimum53Grade)		UltraTech/Birla/ACC/Ambuja/Hathi/Sanghi		
3	Flush doors		BIS approved brand(ISI Mark)		
4	FRP Doors		Fibre vent , Techno skills or Equivalent(or as approved by Engineer In charge)		
5	PVC Doors with Frame		ISI and approved by Engineer In charge		
6	Hydraulic floor Spring/Door		Everite, Garnish, Hardwyn		
7	White Cement		JK White	Birla white	Nihon White
8	Reinforcement/Structural Steel (Each LOT shall accompany manufacturer's Test Certificate)		(TMTBARSFe-500) Gallent /ET/ASR/Friend or BIS approved manufacturers		
9	Dining, Drawing, Bed Room, Kitchen, Toilet/Bath/Wash etc,	Vitrified/ Ceramic /Glaze Tiles/Wall Tiles/Parking Floor Tiles	Somani/Nitco/Kajaria/RAK/Jhonson/Simpolo/Bell/Asian/ Euro/Vermora		
10	Toilet/Bath/Wash	PVC/UPVC Pipes & Fittings	Astral/Supreme/Prince/finolex /Simco/Plumber With Clamp open type of outer side of Building		
11		Sanitary ware	Jaquar/cera/Hindware/Jhonson and any other standard brand as approved by engineer-in-charge		
12	Teak Wood		Bulsar	C.P. Teak	
13	Interlocking Paver blocks		ISI Mark– Balaji, Regency, Supreme		
14	Plywood Products Commercial Block Board Commercial Ply Teak Ply		ISI Mark as approved by engineer-in-charge		
15	Glass/Float/Sheet		Saint Gobain	Modi/HNG	Asahi
16	Laminates		Neolux/Formica/Sunmica/Merino or as per IS		
17	Aluminum sections		Jindal	Indal	Banco

- A) The contractor shall produce samples of the materials for approval of the RMC/PMC. The materials of the makes out of the above as approved by the RMC/PMC shall be used on the work. RMC/PMC member has not bide to give any reason for rejection of any brand from the above list and its decision will be consider as final.
- B) Inrespectofmaterialsforwhichapprovedmakesarenotspecifiedabove,thesewill be of makes to be decided by the RMC / PMC.
- C) Contractor can use for any material of equivalent make of the above specified company after taking prior permission of RMC/PMC.
The agency has to use item/material mentioned in the list above. In no case other item/material shall be allowed except those mentioned in the list unless and until the unavailability of the above said item/material noticed that too, prior approved of RMC/PMC

D. ADDITIONAL CONDITIONS

D. ADDITIONAL CONDITIONS:

1. The contractor shall have to provide his own level instrument for this work.
2. The safety of the traffic and surrounding properties is the prime important factor. As it is the renovation work in existing residential and commercial area the fencing, lighting, covering etc., requires to be provided as per clause 1.1.15. and as per the site requirement. Sign Board shall have to be provided at required locations, so that there will not be any fatal accident.
3. In case of any ambiguity found in inspections / drawings, specifications, etc, the decision of engineer-in-charge shall be final and binding to the contractor.
4. Rates quoted in Bill of Quantities to cover everything necessary for complete Execution of work :

The rates quoted will be held to cover everything necessary of the due and complete execution of the work according to the drawings and the several conditions and the stipulations of the contract, including specification, or the evident intent and meaning of all or either of them or according to customary usage and for the periodical and final inspection and test and proof of the work in every respect and for measuring, numbering or weighing the same including setting out and laying or fixing in position and the provision of all materials,

Power, tool rammers, beaters, labour, tackle platforms with impervious lapped joints for scaffolding ranging rods, straight edges, centering and boxes, wedges, moulds, templates, post straight rails, boning-staves, measuring rods, page boards, shores, barriers, fencing, lighting, pumping apparatus, temporary arrangements of passage of traffic, access to premises and continuance of drainage, water supply and lighting (if interrupted by the work) lard temporary sheds and buildings nahanis roofed in or otherwise haulage, painting, varnishing, polishing, establishments for efficient supervision and watching arrangements for the efficient protection of life and property and all requisite plant, implements and appliances every kind, except only such matter and things as it may be distinctly stated here in are to be supplied by the contractors. A rate for anyone description of work is to be held to include such items of other classes of and for these on separate specific charge will be admitted. The contractors shall keep every portion of the work clear of accumulation from time to time and shall leave every portion of the work clean, clear, perfect and at the

conclusion of whole, providing at their own cost all such material implement appliances and labour as the Engineer may require to prove if it is to be so.

5. The contractors are particularly directed to observe from the Articles of Agreement and the specifications, what is to be included in their rates for the several portions of the work and also under what conditions payments are to be made.
6. The contractor shall have to avail P F Code as per the prevailing Circular of Government for the employees on work. The process for preparation of bill will be taken up only after submission of the Challan for the amount of P.F. deposited every month for the employees on work, which will be binding to the contractor. The required documents shall have to be submitted every month by the contractor to the competent authority.
7. The contractor shall have to get registered under ESI (Employer's State Insurance) Act and obtain ESI Registration number if the number of workers are 10 Nos. or more. Also, the agency shall have to give all the benefits to the workers as available under the ESI Act. The agency should follow all the rules and regulations of ESI Act as per prevailing norms.
8. This office Circular bearing No.RMC/C/329 dated 22-12-2012 and Order No.RMC/C/132 dated 10-06-2013 are uploaded separately as a part of tender document. The Contractors/Consultants quoting their rates shall have to read, implement, and submit the same duly signed along with the documents to be submitted during physical submission.
9. In reference to the above Circular and Order cited para above, the Contractors/Consultant who have quoted their rates for this work will be called in person for verification of original documents. The date and time for verification of original documents will be as prescribed in the tender document.
10. After issuance of work order for this tender, if the work falls under any kind of dispute then Rajkot Municipal Corporation reserves the right to terminate the contract for this work awarded to the contractor or execute part work. The decision of Rajkot Municipal Corporation in this regard will be final and binding to the contractor.
11. Till the Completion Certificate is issued by Rajkot Municipal Corporation, the agency will be the sole responsible for security of material and structure at site.

12. The quantities given in the Schedules are provisional. The Rajkot Municipal Corporation reserves the right to increase or decrease the quantity of work or totally omit any item work and the contractor shall not be entitled to claim any extras or damages on these grounds & he is bound to execute the work as per the instruction of the Engineer-in-charge. Rajkot Municipal Corporation will not entertain any dispute in this regard.
13. It is further clarified that Performance Guarantee (SD) for extra work will also be recovered @ 10% from the bill of extra work i.e. works beyond tender amount.
14. The bidder must understand clearly that the prices quoted are for the totally works or the part of the total works quoted for and include all costs due to materials, labour, equipments, supervision, other services, royalties, taxes, duties, etc., and to include all extra to cover the cost. No claim for additional payment beyond the prices quoted will be entertained and the bidder will not be entitled subsequently to make any claim on any ground.
15. Qualified engineer must be deployed on site and at Plant. The details of qualified engineers are to be given to RMC at the time of bidding of this tender.
16. If any irregularities found during the work then penalty will be imposed by Engineer-in-charge or any higher officer. If any disputes arises regarding penalty imposed by Engineer-in-charge then decision of Municipal Commissioner will be final and binding to agency.
17. The time limit will remain same as mentioned in the tender document and the work is to be completed accordingly.
18. Tender of such Contractor not having registration in appropriate Class and Category, will be treated as non-responsive. In case of any conflicting provisions between registration of appropriate category and Pre-qualification criteria, the later shall govern the process of bid evaluation.
19. The agency shall have to quote their rates only after visiting the site and looking to the site conditions.
20. DEFECTS: Date of completion for start of defect liability period for the entire work will be considered as the last date mentioned in the completion of work recorded in Measurement Book. The contractor shall be required to make good all the damages/ defects identified and conveyed to him, during the entire defect liability period. The

method and time limit of rectification will be decided by the Engineer in charge. If the contractor fails to carry out rectification as per the instructions, the same will be carried out at his cost and the cost will be recovered from the amount retained.

21. Joint venture shall not be allowed under this tender.
22. After the completion of work, at the interval of every three months, joint inspection must be done by the agency and RMC staff and then agency has to submit the report stating the condition of work to Rajkot Municipal Corporation. The final checking report stating the condition of work is also to be submitted by the agency before one month of the expiry of defect liability period to the competent authority.
23. The Royalty of each and every material, required to be paid is to be borne by the contractor.
24. Testing of each material as and when required by Rajkot Municipal Corporation, is to be carried out in Government approved laboratory by the contractor at his own cost. Schedule of testing of material will be as per R&B, State Government Manual and I S Code provision.
25. Necessary tests for material quality, soil tests etc. shall be carried out as per the instructions of engineer-in-charge by contractor at his own cost and reports to be submitted to the engineer-in-charge.
26. As this work is to be done in existing structure and also keeping in mind surrounding properties, all due precautions should be taken so that no damage occurs to any of the services like; water connection, drainage connection, water pipeline, drainage line or any other services. However, if any damage occurs to any of such service(s) then the contractor shall have to carry out necessary repairs immediately and satisfactorily, at his own cost.
27. Wherever the rolling with the road roller is not possible on metalling work and murrum work, the compaction with hand roller or by any other means at such places shall have to be carried out by the contractor satisfactorily as per instructions of engineer-in-charge.
28. The Contractor shall carry out modifications in the procedure of work, if found necessary, as directed by the Engineer during inspection. Works falling short of quality shall be rectified / redone by the Contractor at his own cost, and defective work shall also be removed from the site of works by the Contractor at his own cost.

29. Defective Materials: All materials which the Engineer / his representative has determined as not confirming to the requirements of the Contract shall be rejected whether in place or not; they shall be removed immediately from the site as directed. Materials, which have been subsequently corrected, shall not be used in the work unless approval is accorded in writing by the Engineer. Upon failure of the Contractor to comply with any order of the Engineer / his representative given under this clause, the Engineer-in-charge shall have authority to cause the removal of rejected material and to deduct the removal cost thereof from any payments due to the contractor.
30. The Defect Liability period for this work is 24 months. After completion of work, a report at the interval of every six months by way of joint inspection shall have to be submitted to the competent authority. The portion which is observed defective / damaged by normal cause during the joint inspection shall have to be repaired/ rectified and necessary evidence along with photographs shall also have to be submitted to the competent authority.
31. The agency shall have to get the plans done from the approved Architect / Engineer and also to get approved from the Town Planning Branch of RMC, the cost of which is to be borne by the agency. The agency shall have to get the approval for plan(s) within a period of 30 (Thirty) days.
32. The Plans got prepared by the agency shall have to be get the design done from the Structural Engineer, the cost of which also is to be borne by the agency.
33. The work order will be given only after getting the preliminary approval from Town Planning Department.
34. Providing and fixing of precast RCC slab and column shall have to be carried out in line and level.
35. For excavation of trench, use of JCB machine will not be permitted directly on the top surface of the road. After excavation up to minimum 1.00 mt. depth from road surface or existing ground level, same shall have to be carried out manually or by using Breaker and after locating underground services like; water supply pipeline, water connection lines, pipe gutters, telephone cables, electric cables etc., and thereafter upon taking the prior approval of the Engineer-In-Charge, the excavation can be carried out by using JCB machine.

36. Rajkot Municipal Corporation shall recommend to the competent authority to give Controlled Blasting License to the contractor for carrying out excavation in hard rock. In case of blasting license not permissible from the competent authority in some places then excavation is to be done by using wedges and hammers, chiseling, breakers, pneumatic tools, etc. Also in case where blasting license is permitted but even then if there is no possibility of carrying out the blasting for whatsoever reason, the excavation is to be done by using Wedges and hammers, chiseling, breakers, pneumatic tools etc. No extra payment shall be made for excavation to be carried out in any of the above mentioned both the situations.
37. Excavation in soft rock and hard rock shall have to be carried out only by Chiseling, Breaker (pneumatic tools) etc., as far as possible. If excavation is not possible in terms of above and if excavation is required to be carried out with the help of blasting then the same shall have to be carried out only after taking prior approval and necessary license for blasting from the competent authority.
38. In case of excavation not possible manually or by chiseling in certain place(s) as well as if blasting is also not possible due to various reasons i.e. to avoid damage to nearby water pipeline, pipe gutter, telephone cables / Duct, Raw houses / week buildings / narrow street etc., then the excavation by blasting will not be permitted. Under these circumstances, excavation shall have to be carried out only by Breaker (pneumatic tools) as per the instructions of the Engineer-In-Charge. No extra payment will be made for such type of excavation done by using Breaker. The rate for excavation shall be paid as per the rate of related item mentioned in Schedule-B.
39. Regarding the width of excavation, as (a) it is difficult to carry out the vertical trench excavation, (b) possibility of sliding the soil, and (c) uneven excavation trench width in case of blasting. In this connection, for every 1.5 mt lift if there is less width up to 5 cm at the bottom then the top width of excavated trench, it shall be considered as per the specified trench width or actual trench width carried out at the ground level by the contractor whichever is less. If excavation is carried out more than the specified width then the payment will be made only for the specified width of excavation.
40. After entering into an agreement, the agency shall have to finalize the agency for supply of the material like Precast RCC slab and column and the name of manufacturer / supplier should immediately be informed to Rajkot Municipal Corporation so that Rajkot Municipal Corporation can also expedite the manufacturer / supplier for the material. If necessary, Rajkot Municipal Corporation will visit and inspect the factory. During the inspection, if Rajkot Municipal Corporation is not satisfied then the contractor shall have to procure the material from other manufacturer(s).

41. During construction activity, proper care must be taken for labor safety and all the provisions of the labor laws must be followed by the contractor.
42. The G.A. Drawings and other Drawings as provided at present with the tender document are indicative, however, there is possibility of any change or modification in the said drawing and as such the contractor shall have to carry out the work accordingly at the approved rates without any extra cost.
43. The contracting Agency then has to prepare bar bending schedule as per Structural Drawings and submit it to RMC after then RMC shall permit to work to start. Structure design is in the scope of work of contractor and its cost is to be borne by the contractor. The structure designer should be RMC license holder. The proof check of the structure design should be done by one of the structure designers, as suggested by RMC. (If the structure designer is suggested by RMC, then the proof check is not needed.) Bar Bending Schedule, register shall be maintained on site with the details of cut length of bar. The certificate for same shall be denoted in Pour Card.
44. Contract Agency has to provide a Site Office Room, a separate Laboratory included with necessary lab instruments for slump test, sieve analysis, etc. whatever suggested by Site Engineer in charge on site premises. There shall be provision of minimum 24 cube mould of 15 x 15 x 15 cm size and 12 mould of 7.5 x 7.5 x 7.5 cm. There shall be a provision of necessary stationary & Furniture. The periodical calibration of instruments like weigh batch Plant, Electronic Balance etc. shall be carried out as per instruction of Engineer in Charge. Without satisfactory report for the same the work may not be continued.
45. The Mix Design of Cement Concrete shall be revised submitted with respect to changes in Materials like Cement, Sand, Aggregate
46. The Final Completion Drawings shall be submitted in hard copy and as Auto Cad format by Agency. If the same is not submitted, the permanent deposit 0.25 % of Final Bill amount will be deducted from Final bill.
47. After the drawings for the proposed work are finalized by RMC, the agency has to submit the same to qualified & experienced structure engineer.
48. The agency has to submit the approved & signed copier of structure design 3 sets to Rajkot Municipal Corporation
49. Agency has to get the structure designs proof checked by the structure engineer suggested by Rajkot Municipal Corporation and the fees for the same shall be borne by the agency.

50. Additional alternation changes during the work shall have to be incorporated in the structure drawing & shall be re submitted to Rajkot Municipal Corporation accordingly.
51. The contracting Agency then has to prepare bar bending schedule, submit it to Rajkot Municipal Corporation. &After checking the bar bending schedule, then Rajkot Municipal Corporation shall permit to work to start.
52. Approval to the samples of various materials given by the Engineer-in-charge shall not absolve the contractor from the responsibility of replacing defective material brought on site of materials used in the work found defective at a later date. The contractor shall have no claim to any payment of compensation whatsoever on account of any such materials being rejected by the Engineer-in-charge.
53. The agency has to facilitate the Town Planning department in all respective terms and has to provide all the required items as instructed by a surveyor of Town planning Dept. The items which are required for demarcation are colors, Tags, Nails, labors and agency will also be responsible for cleaning of the plot without any extra cost.
54. The agency has to create the passage/access to the plot where the work is supposed to start. If in case the access to plot is restricted by any farming land, then the agency has to take a proper arrangement for passage and whatever the cost occurred in the construction of the passage, the agency has to pay the cost of its own.
55. The compound wall has to be constructed with the proper guidance by the Engineer- in- charge, such as if the land has difference in the level (irregular topography), then the agency has to construct the compound wall in the step pattern form.
56. The top of the precast wall will be either in Semi-circular or triangular whichever instructed by the Engineer-in-charge. The Measurement of the Semi-circular or triangular item of the precast wall will be taken from the middle of the section of the item.
57. If in case the Semi-circular or triangular item of the precast wall will not be fixed, then the agency has to keep the top section of precast pole empty, without any curtailment in the height of the pole. But the measurement will be counted only for the constructed slabs.
58. In the precast wall, either the cement mortar in the ratio of 1:1 or Standard chemical mortar to be filled in Groove i.e. the area between two precast slabs and the area between the slabs and pole, whichever instructed by the Engineer- in- charge.

59. The restoration work for the excavation done is to be carried out immediately as per the instructions of engineer in charge. The excess material shall have to be disposed with no extra cost at the site specified by engineer-in-charge.

The word "Arbitration" or "Arbitration Clause" wherever mentioned in this tender document, is now to be treated as "Deleted". In this context, an Order bearing No.RMC/Legal/1858 dated 18-02-2017 of Legal Department of Rajkot Municipal Corporation is uploaded separately along with this tender, which Order, will hereafter be referred and taken into consideration for Arbitration related purpose for the tenders of Rajkot Municipal Corporation.

ADDL. CITY ENGINEER
Rajkot Municipal Corporation

Signature of Contractor with Seal

Rajkot Municipal Corporation

:: SPECIAL CONDITIONS ::

1. The Royalty of each and every material, required to be paid is to be borne by the contractor.
2. Testing of each material as and when required by Rajkot Municipal Corporation, is to be carried out by the contractor at his own cost. Schedule of testing of material will be as per R&B, State Government Manual and I S Code provision.
3. The whole work shall be executed by qualified Site Engineer. The required L- Section and Cross section is to be prepared by contractor at his own cost. The work should be done by levelling instrument. The Drawings shall be submitted accordingly in advance before starting the work. No extra payment will be made for the above work. Contractor has to submit Bill form with hard copy and soft copy of cross section and L-section of work completed. No bill will be accepted without above drawings.
4. Necessary tests for material quality, Paving Blocks, soil tests etc. shall be carried out as per the instructions of engineer-in-charge by contractor at his own cost and reports to be submitted to the engineer-in-charge.
5. The contractor shall have to get registered under ESI (Employer's State Insurance) Act and obtain ESI Registration number if the number of workers are 10 Nos. or more. Also, the agency shall have to give all the benefits to the workers as available under the ESI Act. The agency should follow all the rules and regulations of ESI Act as per prevailing norms.
6. The testing of metal and the design as per IRC shall have to be carried out by the contractor at his own cost.
7. Plan, Elevation, section with structure design is to be prepared by contractor and after approval of engineer-in-charge the work can be started. The fees for the Structure Design shall be borne by the agency.
8. Agency intending to carry out excavation will be able to carry out excavation / digging only after prior intimation through "Call before U Dig" mobile application.

ADDL. CITY ENGINEER
Rajkot Municipal Corporation

Signature of Contractor with Seal

PART-III
BILL OF QUANTITIES
(Attached in Separate Folder)

BID FORM (WITH PRICE)

CONTACT No: RMC/ENGG/CZ/24-25/7-6

Bidders are required to fill up all blank spaces in this Bid Form

The Commissioner
Rajkot Municipal Corporation
Dr. Ambedkar Bhavan
Dhebar Road
Rajkot

Dear Sir,

SUB: (A) RENNOVATION WORK OF AVANTIBAI LODHI COMMUNITY HALL
(B) CONSTRUCTION OF SECURITY QUARTER AND STAFF OFFICE IN
SIXAN SAMITI OFFICE CAMPUS
(C) RENNOVATION OF WARD OFFICE-7C ON BHUPENDRA ROAD &
WARD OFFICE 7-D HATHIKHANA IN WARD NO.-7

1. Having visited the site and examined the Bid Documents, Drawings, Conditions of Contract, Specifications, Schedules, Annexures, Preamble to Price Schedules, Price Schedules etc. including Addenda/Amendments to the above, for the execution of the above Contract, we the undersigned offer to carry out as given in Conditions of Contract and in conformity with the Drawings, Conditions of Contract, Specifications, Preamble to Price Schedules, Price Schedules, Annexures, Bidding Documents, including Addenda Nos. _____ (insert numbers) for _____ %age (in _____ figure)

(in words) below / above than the rates given in Price Schedule.

2. I / We agree that
- (a) if we fail to provide required facilities to the Employer's representative or any other person/agency by the employer to perform on his behalf for carrying out the inspection and testing of materials and workmanship
- or
- (b) if we incorporate into the Works, materials before they are tested and approved by the Engineer's representative
- or
- (c) if we fail to deliver raw water of required quantity according to the conditions/stipulations of the Contract, the Engineer will be at liberty to take any action including termination of Contract and impose at his absolute discretion any penalties, and/or reject the work.

3. We undertake, if our Bid is accepted, to complete and deliver the Works in accordance with the Contract within **9 months** of construction period from the date of Work Order issued to us by you.
4. We agree to abide by this Bid for a period of 120 days from the date fixed for receiving the same and it shall remain binding upon us and may be accepted at any time before the expiry of that period.
5. In the event of our Bid being accepted, we agree to enter into a formal Contract Agreement with you incorporating the conditions of Contract thereto annexed but until such agreement is prepared this Bid together with your written acceptance thereof shall constitute a binding Contract between us.
6. We agree, if our Bid is accepted, to furnish Performance Bond/Security in the forms and of value specified in the Conditions of Contract of a sum equivalent to 5% of the Contract price for due performance of the Contract.
7. We have independently considered the amounts of liquidated damages shown in Appendix to Bid and agree that they represent a fair estimate of the damages likely to be suffered by you in the event of the Work not being completed by us in time.
8. We understand that you are not bound to accept the lowest or any Bid you may receive.

Dated _____ this _____ day of _____ 2016.

(Signature)

Company Seal

(Name of the person)

(Name of firm)

(In the capacity of)

Duly authorised to sign Bid for and on behalf of
(Fill in block capitals)

Witness

Signature _____

Name _____

Address _____

PREAMBLE TO PRICE SCHEDULES

Note on Schedule:

The bid is percentage rate bid for (A) RENNOVATION WORK OF AVANTI BAI LODHI COMMUNITY HALL (B) CONSTRUCTION OF SECURITY QUARTER AND STAFF OFFICE IN SIXAN SAMITI OFFICE CAMPUS (C) RENNOVATION OF WARD OFFICE-7C ON BHUPENDRA ROAD & WARD OFFICE 7-D HATHI KHANA IN WARD NO.-7

1. The bid is percentage rate bid.
2. The rates and prices shall be submitted in the formats given in the online Price Schedules. Rates and prices received in any other formats will be rejected and the Bids will be disqualified.
3. It will be entirely at the discretion of the Employer to accept or reject the bidder's proposal, without giving any reasons whatsoever.
4. In Price Schedule, bidder shall quote his percentage Equal/Above/Below for items listed in the schedule. Prices quoted in Schedule only will be considered for price evaluation & shall form a part of the Contract Agreement.
5. The Only Price Schedule will be considered for financial evaluation of the bid with the successful bidder.
6. The bidder shall be deemed to have allowed in his price for provision, maintenance and final removal of all temporary works of whatsoever nature required for construction including temporary bunds, diverting water, pumping, dewatering etc. for the proper execution of works. The rates shall also be deemed to include any works and setting out that may be required to be carried out for laying out of all the works involved.
7. Where there is a discrepancy between the unit rates and the amount entered, the latter shall govern.
8. The Price Schedules are to be read in conjunction with the Conditions of Contract, the Specifications and other sections of these bid documents and these documents are to be taken as mutually explanatory of one another.
9. Prices quoted by the bidder shall be firm for the entire period of Contract without any escalation.
10. The bidder shall interpret the data furnished and carry out any additional survey work, or investigative work required at his own cost.
11. The prices quoted shall also include the cost of materials utilized for testing.

12. The bidder should acquaint himself with the site conditions including the access to Worksite. The successful bidder shall have to make suitable access to worksites at his own cost. These accesses will be used by the other contractors working for RMC.
13. The material shall be inspected Departmentally, the cost of which, if any, is to be borne by contractor.
14. The contractor shall have to quote their rates including GST and other taxes and the Invoice with break-up of GST is to be submitted accordingly, failing which, such amount will be deducted from the bill of the agency and deposited accordingly.

The contractor shall have to purchase the material required for this tender work, only from the supplier having registered GST Number. RMC will not be responsible to pay any amount towards GST if the material is purchased from the unregistered supplier not having GST Number.

15. In case of extra item work if quoted and approved tender price is above Percentage Rate then no above percentage rate will be given, only the rates as per S.O.R. will be paid for such extra item. But, if the quoted and approved tender price is below percentage rate then that below percentage rate will be considered for paying of any extra item.
16. The whole work is to be done under the supervision of RMC.
17. The rates and prices shall be submitted in the formats given in the enclosed Price Schedules. Rates and prices received in any other formats will be rejected and the Bids will be disqualified.
18. It will be entirely at the discretion of the Employer to accept or reject the bidder's proposal, without giving any reasons whatsoever.
19. In Price Schedule, bidder shall quote his percentage Equal/Above/Below for items listed in the schedule. Prices quoted in Schedule only will be considered for price evaluation & shall form a part of the Contract Agreement.
20. Only Price Schedule will be considered for financial evaluation of the bid with the successful bidder.
21. The Price Schedules are to be read in conjunction with the Conditions of Contract, the Specifications and other sections of these bid documents and these documents are to be taken as mutually explanatory of one another.

22. Prices quoted by the bidder shall be firm for the entire period of Contract without any escalation.
23. The bidder shall interpret the data furnished and carry out any additional survey work, or investigation work required at his own cost.
24. The prices quoted shall also include the cost of materials utilized for testing.
25. The bidder should acquaint himself with the site conditions including the access to Worksite. The successful bidder shall have to make suitable access to worksites at his own cost. These accesses will be used by the other contractors working for RMC.
26. From each Running Account Bill, labour cess will be deducted as per norms.
27. In Every running bill 0.25% amount shall be retained as extra security deposit if Drawings of work done are not submitted by agency.
28. The quoted rates should be inclusive of all taxes and duties.
29. The prices shall have to be quoted firm & fix including all the taxes & dutes without any statutory variation. RMC will not consider any statutory variation as well as the price rise in the market and if any, those shall be on account of contractor.
30. The work contract tax will be borne by the agency.
31. For this project works / SJMMSVY Grant / 14th & 15th Finance Commission works, Third Party Inspection (TPI) is mandatory. The TPI agency will be appointed by Rajkot Municipal Corporation and remittance of charges @0.70% of contract value for the same is to be borne by the agency, which will be deducted from the contractor's bill.
32. While considering experience of ongoing sewer/storm water pipeline works, part work completed in all respect will be considered for evaluation of bid. In this regard contractor shall be required to submit part completion certificate along with bid document from competent authority.
33. Use of ready mix concrete may be permitted if it fulfils tender specifications.
34. No extra item or extra width will be paid due to excavating method or type of machinery.

35. For any type of license regarding labour, etc. has to be achieved by agency.
36. This office Circular bearing No. RMC/C/329 dated 22-12-2012 and Order No. RMC/C/132 dated 10-06-2013 are uploaded in tender document.
37. In reference to the above Circular and Order cited at above, the Contractor firm who have quoted their rates for this work will be called in person for verification of original documents. The date and time for verification of original documents will be intimated to the Contractors.
38. If the progress of work is found slow then Extra security Deposit may be recovered from any running bill as decided by Engineer in charge up to maximum 5% amount of concerned R.A. Bill amount.
39. In case of Extra Item, No "On" %age i.e. +ve % age Rate will be given but if there is Down %age i.e, -ve % age Rate that will be applied to that rate of that Extra Item.

ADDL. CITY ENGINEER
Rajkot Municipal Corporation

Signature of Contractor with Seal

Check List for submission of Documents	
Tender Fee submitted as per Tender	Yes / No
Tender Earnest Money Deposit submitted as per Tender	Yes / No
Registration documents submitted as per tender requirement	Yes / No
Financial Details:	
Turnover details submitted as per requirement	Yes / No
Working Capital as per requirement of tender is submitted	Yes / No
Valid Bank Solvency submitted	Yes / No
Validity of Bank Solvency	Date:
Experience Details:	
Details of Technical Staff and details of machineries submitted	Yes / No
Address proof submitted	Yes / No
Identity proof submitted	Yes / No
Fresh Declaration on Non-Judicial Stamp Paper regarding not black listed or Terminated or Debarred, is submitted	Yes / No
Professional Tax Receipt of current year	Yes / No

Note:

Over and above, the agency shall also have to submit all other necessary documents as may be required for pre-qualification, failing which, the agency will be treated as Non-responsive and will be DISQUALIFIED and also the online price bid of such agency will not be opened.

Signature of Contractor with seal

PRICE SCHEDULE

Name of work: (A) RENNOVATION WORK OF AVANTIBAI LODHI COMMUNITY HALL
(B) CONSTRUCTION OF SECURITY QUARTER AND STAFF OFFICE IN SIXAN SAMITI OFFICE CAMPUS (C) RENNOVATION OF WARD OFFICE 7-C ON BHUPENDRA ROAD AND WARD OFFICE 7-D NEAR HATHIKHANA IN WARD NO.7

SUMMARY

	Details	Amount (Rs)	GST 18%	Total (Rs)
(A)	RENNOVATION WORK OF AVANTIBAI LODHI COMMUNITY HALL	18,25,337.00	3,28,560.66	21,53,897.66
(B)	CONSTRUCTION OF SECURITY QUARTER AND STAFF OFFICE IN SIXAN SAMITI OFFICE CAMPUS	12,42,925.95	2,23,726.67	14,66,652.62
(C)	RENNOVATION OF WARD OFFICE 7-C ON BHUPENDRA ROAD AND WARD OFFICE 7-D HATHIKHANA	13,56,543.20	2,44,177.78	16,00,720.98
	Total	44,24,806.15	7,96,465.11	52,21,271.26
	Say	44,25,000.00		52,22,000.00

Rajkot Municipal Corporation

Price Schedule – B1

Name of work: RENNOVATION WORK OF AVANTIBAI LODHI COMMUNITY HALL IN WARD NO.7

SR	Description	Rate	Quantity	Unit	Amount
1	Removal of Flooring of type Shabadi Ladi / Cement / Tiles flooring	40.00	400.00	Sq.mt	16000.00
2	Removal of Block	24.00	50.00	Sq.mt	1200.00
3	Removal of door & window	148.00	39.00	No	5772.00
4	Excavation of Foundation in Soft Murrum, Soil or Sand from 0.0 mtr. to 1.50 mtr depth including dewatering with lifting and laying in RMC limit as instructed	133.00	15.00	Cu.mt	1995.00
5	Foundation filling with CC work in proportion of 1:3:6 using 1.5 cm to 2.0 cm aggregate including Raming, Curing etc.	3965.00	4.00	Cu.mt	15860.00
6	Supply & Fixing of Broken Glazed (China Mosaic) tiles size 5-6 mm thick of different size and shade (approved crazy pattern) in Cement:Mortar 1:2 and joint filling with White Cement / Coloured Cement including Ramping, Watering, Curing etc. complete	306.00	320.00	Sq.mt	97920.00
7	S & F of vitrified tiles 1st	650.00	125.00	Sq.mt	81250.00
8	Supply, Fixing & Polishing of Kota Stone work thickness 20-25 mm to be fixed in Lime:Mortar 1:2 and liquid Cement and as instructed	913.00	150.00	Sq.mt	136950.00
9	Supply & Fixing of 60mm M-30 Grade	520.00	50.00	Sq.mt	26000.00

	cement concrete rubber mold paving inter locking paving block (Grey colour) after bedingof Bhogavo sand in line and CC on the edge in proportion of 1:2:4 with curing etc. complete				
10	Removal of Excavated Stuff within RMC limit as directed by Engineer-in-Charge	171.00	30.00	Cu.mt	5130.00
11	Removal of Cement / Lime Plaster open joint etc	23.00	460.00	Sq.mt	10580.00
12	20mm thick Sand Face Cement Plaster Work in which 1 paster in proportion of 1:3 and 2nd plaster inteh proportion of 1:2 using Cement:Mortar with spong finishing etc. complete (Note: Before carringout Plaster work on RCC, required tipping work should be carried out as instructed)	263.00	50.00	Sq.mt	10580.00
13	Cement Plaster Work 12mm average thick using Cement:Mortar in proportion of 1:3 rough cast (without Niru Finishing)	207.00	460.00	Sq.mt	95220.00
14	Birla or JK putti work on rough plaster (three times) with labour and material	82.00	1810.00	Sq.mt	148420.00
15	Apex Color work on Outer side of Wall (Two coats) (with Base Coat)	115.00	1080.00	Sq.mt	124200.00
16	Plastic Imulsion Paint (Two coats) (Asian Paint, ICI, Dulux, Nerolac, Berger etc. of approved type) (with Prime Coat)	145.00	1830.00	Sq.mt	265350.00
17	S.S. railling S.S. pipe 304 grade with all fixture & fastening etc.complete	2132.00	26.00	R.mt	55432.00
18	Enemal painting on door/window, iron door, iron grill or woodwork two coat	125.00	190.00	Sq.mt	23750.00
19	Repairing of doors & windows	628.00	80.00	Sq.mt	50240.00
20	Supply & Fixing of Granite stone on wall after rough cast cement paster in proportion of 1:3 and fixing grainate in Cement Paste (any color- 2nd class)	1474.00	90.00	Sq.mt	132660.00
21	Flush Door 25mm thick (without frame) for Door & window with polishing / oil painting using company viz. Kitply / Century / Dura/ Everest etc ISI brand only(with necessary all fittings)	1788.00	45.00	Sq.mt	80460.00
22	Providing & fixing FRP door.	4200.00	15.00	Sq.mt	63000.00
23	Uropean type w/c with sit, cover fixing with comp. standard quality.	1784.00	4.00	Nos	7136.00
24	Supply & Fixing of Orrisa Pan white porselin standard size	1157.00	2.00	Nos	2314.00
25	White porselin Kitchen Sink size 60/450/200 mm with supply and fitting.	2803.00	2.00	Nos	5606.00
26	mirror approved quality 40 x 30cm size bracket fitting with fixing	445.00	2.00	Nos	890.00
27	S & L Rigid P.V.C. Pipe ISI Marked of 6 kg/sq.cm. Pressure, required with coupler, for pipe of 110 m.m.outer dia.	262.00	20.00	R.mt	5240.00
28	Brass cock screw down bolt type 15mm dia. fitting with fixing.	242.00	20.00	Nos	4840.00
29	Flushing Valve Brass Cromium Platted push cock or handle type with flushing supply and fixing	811.00	4.00	Nos	3244.00
30	Glazed Stoneware ISI pipe supply, laying, jointing, fixing work of pipes	188.00	20.00	R.mt	3760.00

	required. Specials jointing materials, lighting, all necessary safety arrangements and necessary testing to be done. (Excluding excavation, bedding and refilling). for pipe of 150 m.m. dia. With supply and fixing. Only fixing work				
31	Drainage house connection should construction either (square /round) withg brick masonry type (0.50m* 0.50m) in which the bottom should be of CC 1:3:6 with brick masonry 1:4 cum plaster 1:3 cm coping CC 1:1:2 and also benching around it with 1:2:4 should be done with finishing, curing and fixing framecover. (excluding excavation or suplly of frame cover) (More than 0.60 meter and up to 0.75 meter depth)	3374.00	4.00	Nos	13496.00
32	Precast R.C.C. circular manhole cover+frame supply complete with fixing 600 mm diameter with 5 tone of capacity.	1508.00	4.00	Nos	6032.00
33	Providing & fixing 0.60×x 0.60 sizetiles & galvenized frame on gypsam board, faulse ceiling with moulding & designed patta.	848.00	380.00	Sq.mt	322240.00
				Total	1825337.00
				ADD : 18% GST	328560.66
				Total	2153897.66
				Say	2154000.00

Rajkot Municipal Corporation
Price Schedule – B2

Name of work: CONSTRUCTION OF SECURITY QUARTER AND STAFF OFFICE IN SIXAN SAMITI OFFICE CAMPUS

SR	Description	Rate	Quantity	Unit	Amount
1	Excavation of Foundation in Soft Murrum, Soil or Sand from 0.0 mtr. to 1.50 mtr depth including dewatering with lifting and laying in RMC limit as instructed	133.00	15.00	Cu.mt	5320.00
2	Foundation filling with CC work in proportion of 1:2:4 using 1.5 cm to 2.0 cm aggregate including Raming, Curing etc.	4626.00	10.00	Cu.mt	46260.00
3	CC work M-20 for RCC footing using aggregate of size 10-20 mm, centring, curing, finishing etc. complete (without reinforcement)	5500.00	7.00	Cu.mt	38500.00
4	CC work M-20 for RCC Column using aggregate of size 10-20 mm, centring, curing, finishing etc. complete (without reinforcement)	6400.00	3.00	Cu.mt	19200.00
5	CC work M-20 for RCC Beam using aggregate of size 10-20 mm, centring, curing, finishing etc. complete (without reinforcement)	6100.00	6.00	Cu.mt	36600.00
6	CC work M-20 for RCC Slab using aggregate of size 10-20 mm, centring, curing, finishing etc. complete (without reinforcement)	6000.00	11.00	Cu.mt	66000.00
7	CC work M-20 for Chhajja using aggregate of size 10-20 mm, centring, curing, finishing etc. complete (without reinforcement)	5800.00	1.00	Cu.mt	5800.00
8	Dismantelling of Super Structure and disposing it in RMC area	313.00	9.00	Cu.mt	2817.00
9	Cement Plaster Work 12mm average thick using Cement:Mortar in proportion of 1:3 rough cast (without Niru Finishing)	223.00	200.00	Sq.mt	44600.00
10	20mm thick Sand Face Cement Plaster Work in which 1 paster in proportion of 1:3 and 2nd plaster inteh proportion of 1:2 using Cement:Mortar with spong finishing etc. complete (Note: Before carringout Plaster work on RCC, required tipping work should be carried out as instructed)	263.00	130.00	Sq.mt	34190.00
11	Supply & Fixing of Broken Glazed (China Mosaic) tiles size 5-6 mm thick of different size and shade (approved crazy	306.00	85.00	Sq.mt	26010.00

	patern) in Cement:Mortar 1:2 and joint filling with White Cement / Coloured Cement including Ramping, Watering, Curing etc. complete.				
12	Supply & Fixing of Glazed tiles (1st Quality) of required size in Cement Roga and joints to be filled with white cement after 12mm rough plaster in proportion of 1:3	493.00	30.00	Sq.mt	14790.00
13	Supply & fixing of Vitrified flooring work (1st quality)	650.00	80.00	Sq.mt	52000.00
14	Supplying and fixing alluminium frame 62.50 x 25 mm. size and 37.50 x 18mm size shutter with sliding frame 2-track of standard compeny etc. complete.	4088.00	15.00	Sq.mt	61320.00
15	Apex Color work on Outer side of Wall (Two coats) (with Base Coat)	115.00	130.00	Sq.mt	14950.00
16	Brick Masonry work in Cement:Mortar 1:6	5761.00	43.00	Cu.mt	247723.00
17	Brick Masonry Partition Wall in Cement :Mortar 1:4 (3.5 to 4.5 inch thick)	24.00	10.00	Sq.mt	240.00
18	Supply & laying of Machine crushed agregate of size 25-38 mm	916.00	6.00	Cu.mt	5496.00
19	S &F frp door	4200.00	2.00	Sq.mt	8400.00
20	Iron work as per instruction	109.00	400.00	Kg.	43600.00
21	Supply & Fixing of Granite Stone (Telephone Black Color) on wall after rough cast Cement Plaster in proportion of 1:3 and fixing grainage in Cement Paste	2882.00	25.00	Sq.mt	72050.00
22	Enemal painting on door/window, iron door, iron grill or woodwork two coat	125.00	30.00	Sq.mt	3750.00
23	Numbering on building	11.00	75.00	Char.	825.00
24	Plastic Imulsion Paint (Two coats) (Asian Paint, ICI, Dulux, Nerolac, Berger etc. of approved type) (with Prime Coat)	145.00	200.00	Sq.mt	29000.00
25	Making cupboard with 18mm plywood which 6mm ply back side, 0.8mm white lamination inner side, fixing approved quality sunmica, hinges, stoper etc. 18mm thick ply with both side lamination for selves. plywood brands - kitply, century, dura, everest.etc with ISI marked	8610.00	11.00	Sq.mt	94710.00
26	Flush Door 25mm thick (without frame) for Door & window with polishing / oil painting using company viz. Kitply / Century / Dura / Everest	1788.00	11.00	Sq.mt	19668.00
27	Supply, Fixing & Polishing for Granite Flooring work 18mm thick & 200 mm Base of Lime:Mortar in proportion of 1:2 (telephone black color)	2970.00	3.00	Sq.mt	8910.00
28	Supply & Fixing of Polished of Kota Stone of required size & thickness as instructed to fixed in Platform / CupBoard etc	858.00	5.00	Sq.mt	4290.00
29	Glazed Stoneware ISI pipe supply, laying, jointing, fixing work of pipes required. Specials jointing materials, lighting, all necessary safety	399.00	15.00	R.mt	5985.00

	arrangements and necessary testing to be done. (Excluding excavation, bedding and refilling). for pipe of 150 m.m. dia. With supply and fixing.				
30	Drainage house connection should construction either (square /round) withg brick masonry type (0.50m* 0.50m) in which the bottom should be of CC 1:3:6 with brick masonry 1:4 cum plaster 1:3 cm coping CC 1:1:2 and also benching around it with 1:2:4 should be done with finishing,curing and fixing framecover.(excluding excavation or supllly of frame cover) (More than 0.45 meter and up to 0.60 meter depth	2742.00	2.00	Nos	5484.00
31	Precast R.C.C. circular manhole cover+frame supply complete with fixing 600 mm diameter with 5 tone of capacity.	1508.00	2.00	Pair	3016.00
32	Fixing teakwood frame & 18mm plywood shutters on existing selves, 0.8mm lamination innerside, Alluminium fittings, stoper,lock, paint complete	1558.00	3.00	Sq.mt	4674.00
33	Uropean type w/c with sit, cover fixing with comp. standard quality.	1784.00	1.00	Nos	1784.00
34	White porselin wash bassin 560/410mm indian make c.i. bracket with fitting cromium plated topes 25cm plastic waste pipe and 12mm pillar cock with comp.	1434.00	1.00	Nos	1434.00
35	Nahni trape 7.6cm of PVC fitting and fixing	258.00	2.00	Nos	516.00
36	Brass toper cock 15mm dia. fitting with fixing.	151.00	3.00	Nos	453.00
37	Rigid P.V.C. Pipe ISI Marked of 6 kg/sq.cm. Pressure, required with coupler, supplies + Laying work. for pipe of 110 m.m.outer dia.	188.00	20.00	R.mt	3760.00
38	uPVC pipes of Shedule-40 of any standard approved brand & quality. For 15 mm Ø. (2.77 mm min. wall thickness)	37.62	10.00	R.mt	376.20
39	uPVC pipes of Shedule-40 of any standard approved brand & quality. For 25 mm Ø. (3.38 mm min. wall thickness)	71.25	15.00	R.mt	1068.75
40	Water Storage Tank of HDPE material cylindrical Vertical Black with closed Top 'SINTEX' Brand. (1000 Liter Capacity).	13396.00	1.00	Nos	13396.00
41	Removal of Excavated Stuff within RMC limit as directed by Engineer-in-Charge	171.00	60.00	Cu.mt	10260.00
42	Supplying, Cutting, Bending, Binding and Hooking and binding with wire for RCC work Tor steel TMT round bar including all cost	65.00	2700.00	Kg	175500.00
43	Birla or JK putti work on rough plaster (three times) with labour and material	82.00	100.00	Sq.mt	8200.00
				Total	1242925.95
				ADD : 18% GST	223726.67
				Total	1466252.62
				Say	14,67,000/-

Rajkot Municipal Corporation

Price Schedule – B3

Name of work: (C) RENNOVATION OF WARD OFFICE 7-C ON BHUPENDRA ROAD AND WARD OFFICE 7-D HATHI KHANA IN WARD NO.-7

SR	Description	Rate	Quantity	Unit	Amount
1	Excavation of Foundation in Soft Murrum, Soil or Sand from 0.0 mtr. to 1.50 mtr depth including dewatering with lifting and laying in RMC limit as instructed	133.00	60.00	Cu.mt	7980.00
2	Foundation filling with CC work in proportion of 1:2:4 using 1.5 cm to 2.0 cm aggregate including Raming, Curing etc.	4626.00	11.00	Cu.mt	50886.00
3	CC work M-20 for RCC footing using aggregate of size 10-20 mm, centring, curing, finishing etc. complete (without reinforcement)	5500.00	12.00	Cu.mt	66000.00
4	CC work M-20 for RCC Column using aggregate of size 10-20 mm, centring, curing, finishing etc. complete (without reinforcement)	6400.00	6.00	Cu.mt	38400.00
5	CC work M-20 for RCC Beam using aggregate of size 10-20 mm, centring, curing, finishing etc. complete (without reinforcement)	6100.00	7.00	Cu.mt	42700.00
6	CC work M-20 for RCC Slab using aggregate of size 10-20 mm, centring, curing, finishing etc. complete (without reinforcement)	6000.00	11.00	Cu.mt	66000.00
7	CC work M-20 for Chhajja using aggregate of size 10-20 mm, centring, curing, finishing etc. complete (without reinforcement)	5800.00	2.00	Cu.mt	11600.00
8	Dismantelling of Super Structure and disposing it in RMC area	313.00	13.00	Cu.mt	4069.00
9	Dismantelling Cement concrete or RCC Disposing it in RMC area	410.00	11.00	Cu.mt	4510.00
10	Removal of Cement / Lime Plaster (with excavation of vatta)	23.00	320.00	Sq.mt	7360.00
11	Removal of Flooring of type Shabadi Ladi / Cement / Tiles flooring	40.00	200.00	Sq.mt	8000.00
12	Cement Plaster 12 mm thick using Cement:Mortar in proportion 1:3 with Niru Finishing curing, etc. complete (without Niru Finishing)	223.00	75.00	Sq.mt	16725.00
13	20mm thick Sand Face Cement Plaster Work in which 1 paster in proportion of 1:3 and 2nd plaster inteh proportion of 1:2 using Cement:Mortar with spong finishing etc. complete (Note: Before	263.00	200.00	Sq.mt	52600.00

	carringout Plaster work on RCC, required tipping work should be carried out as instructed)				
14	Supply & Fixing of Broken Glazed (China Mosaic) tiles size 5-6 mm thick of different size and shade (approved crazy patern) in Cement:Mortar 1:2 and joint filling with White Cement / Coloured Cement including Ramping, Watering, Curing etc. complete.	306.00	60.00	Sq.mt	18360.00
15	Supply & Fixing of Glazed tiles (1st Quality) of required size in Cement Roga and joints to be filled with white cement after 12mm rough plaster in proportion of 1:3	493.00	170.00	Sq.mt	83810.00
16	Supply & fixing of Vitrified flooring work (1st quality)	650.00	70.00	Sq.mt	45500.00
17	Supplying and fixing alluminium frame 62.50 x 25 mm. size and 37.50 x 18mm size shutter with sliding frame 2-track of standard compeny etc. complete.	4088.00	20.00	Cu.mt	81760.00
18	Apex color work	115.00	190.00	Sq.mt	21850.00
19	Brick Masonry work in Cement:Mortar 1:6	5761.00	13.00	Cu.mt	74893.00
20	Removal work of Interlocking block	24.00	45.00	Sq.mt	1080.00
21	Supply & Fixing of 60mm M-30 Grade cement concrete rubber mold paving inter locking paving block (Grey colour) after beding of black stone powder in line and CC on the edge in proportion of 1:2:4 with curing etc.complete	500.00	60.00	Sq.mt	30000.00
22	Fixing of CC Precast Road Divider stone 0.38 x 0.30 x 0.20 cm including required material and labour (without colour)	134.00	15.00	Nos.	2010.00
23	Painting of Traffic Strip Footpath / Circle & divider block size 0.38 x 0.30 x 0.30 in two coats using enamble paint in different colors	54.00	30.00	R.mt	1620.00
24	Supply & laying of Machine crushed agregate of size 25-38 mm	916.00	8.00	Cu.mt	7328.00
25	Removal of door/window	148.00	13.00	Nos.	1924.00
26	S & F frp door	4200.00	4.00	Sq.mt	16800.00
27	Iron work as per instruction	109.00	350.00	Kg.	38150.00
28	S & F of granite	2882.00	18.00	Sq.mt	51876.00
29	Enemal painting on door/window, iron door, iron grill or woodwork two coat	125.00	40.00	Sq.mt	5000.00
30	Numbering on building	11.00	100.00	Char	1100.00
31	Plastic Imulsion Paint (Two coats) (Asian Paint, ICI, Dulux, Nerolac, Berger etc. of approved type) (with Prime Coat)	145.00	140.00	Sq.mt	20300.00
32	Making tabel 0.75mt. Height, 18mm approved plywood, 1mm laminates,required lock arrangment, sliding drawer, handel etc. fiting fixing complete	15542.00	4.00	Sq.mt	62168.00
33	Making cupboard with 18mm plywood which 6mm ply back side, 0.8mm white lamination inner side, fixing approved quality sunmica, hinges, stoper etc. 18mm thick	8610.00	16.00	Sq.mt	137760.00

	ply with both side lamination for selves. plywood brands - kitply, century, dura, everest.etc with ISI marked				
34	Flush Door 25mm thick (without frame) for Door & window with polishing / oil painting using company viz. Kitply / Century / Dura / Everest	1788.00	9.00	Sq.mt	16092.00
35	S & L of stoneware pipe 150mm Dia.	399.00	15.00	R.mt	5985.00
36	H.C work up to 0.60mt	2742.00	2.00	Nos	5484.00
37	S & F of frame+cover 0.60 mt.Dia.	1508.00	2.00	Nos	3016.00
38	White Porselin Urinal with require plastic waste pipe fitting and fixing.	1558.00	2.00	Nos.	3116.00
39	Uropean type w/c with sit, cover fixing with comp. standard quality.	1784.00	2.00	Nos.	3568.00
40	White porselin wash bassin 560/410mm indian make c.i. bracket with fitting cromium platted topes 25cm plastic waste pipe and 12mm pillar cock with comp.	1434.00	2.00	Nos.	2868.00
41	Nahni trape 7.6cm of PVC fitting and fixing	258.00	2.00	Nos.	516.00
42	Brass toper cock 15mm dia. fitting with fixing.	151.00	6.00	Nos.	906.00
43	Rigid P.V.C. Pipe ISI Marked of 6 kg/sq.cm. Pressure, required with coupler, supplies + Laying work.for pipe of 110 m.m.outer dia.	188.00	20.00	R.mt	3760.00
44	uPVC pipes of Shedule-40 of any standard approved brand & quality. For 15 mm Ø. (2.77 mm min. wall thickness)	37.62	10.00	R.mt	376.20
45	uPVC pipes of Shedule-40 of any standard approved brand & quality. For 25 mm Ø. (3.38 mm min. wall thickness)	71.25	20.00	R.mt	1425.00
46	Water Storage Tank of HDPE material cylindrical Vertical Black with closed Top 'SINTEX' Brand. (1000 Liter Capacity).	13396.00	2.00	Nos	26792.00
47	Removal of Excavated Stuff within RMC limit as directed by Engineer-in-Charge	171.00	120.00	Cu.mt	20520.00
48	Supplying, Cutting, Bending, Binding and Hooking and binding with wire for RCC work Tor steel TMT round bar including all cost	65.00	2800.00	Kg	182000.00
				Total	1356543.20
				ADD : 18% GST	244177.78
				Total	1600720.98
				Say	16,01,000/-

Addl/Asst. Engineer
R.M.C.

Dy.Ex.Engineer
R.M.C.

ADDL. CITY ENGINEER
R.M.C.

I/We agree to carry out the above said work at (to be quoted online) % Equal / above / below on the tendered rates shown in Schedule.

Signature of Contractor with Seal



રાજકોટ મહાનગરપાલિકા

ડો. આંબેડકર ભવન, ઢેબરભાઈ રોડ, રાજકોટ - ૩૬૦ ૦૦૧.

વેબસાઈટ : www.rmc.gov.in

આર.એમ.સી./સી./વીજી. (ટેક) /જા. નં. - ૨૩૦૯

તા. ૧૧/૦૩/૨૦૨૨

પરીપત્ર:-

રાજકોટ મહાનગરપાલિકા અને RSCDL ખાતે ટેન્ડરથી થતા કામમાં સિમેન્ટ કોન્ક્રીટની કામગીરી કરવામાં આવે છે. આ કામોમાં ક્વોલિટી કન્ટ્રોલ જાળવાઈ રહે તે માટે નીચે દર્શાવેલ દર્શાવ્યા મુજબ જુદા જુદા સિમેન્ટ કોન્ક્રીટ ગ્રેડ વાઈઝ મીનીમમ સિમેન્ટ કન્ટેન્ટના ધોરણો અનુસરવા અને તેનો સમાવેશ ટેન્ડર ડોક્યુમેન્ટમાં કરવા આથી હુકમ કરવામાં આવે છે.

(અ)	NABL માન્ય લેબ દ્વારા IS, IRC કે MORTH મુજબ તૈયાર કરાયેલ સિમેન્ટ કોન્ક્રીટ મીક્સ ડિઝાઈન રીપોર્ટ મુજબ કિગ્રા સિમેન્ટ કન્ટેન્ટ પ્રતિ ઘનમીટર
(બ)	નીચે દર્શાવેલ ટેબલ મુજબ મીનીમમ કિગ્રા સિમેન્ટ કન્ટેન્ટ પ્રતિ ઘનમીટર

Sr. No.	Cement Concrete Grade	28 Days Strength in N/mm ²	Minimum Cement in Kg
1	M-7.5 for PCC Work	7.5 N/mm ²	160 Kg
2	M-10 for PCC Work	10 N/mm ²	220 Kg
3	M-15 for PCC Work	15 N/mm ²	290 Kg
4	M-20 for RCC Work	20 N/mm ²	360 Kg
5	M-25 for RCC Work	25 N/mm ²	380 Kg
6	M-30 for RCC Work	30 N/mm ²	410 Kg
7	M-35 for RCC Work	35 N/mm ²	425 Kg
8	M-40 for RCC Work	40 N/mm ²	440 Kg
9	M-45 for RCC Work	45 N/mm ²	450 Kg

ઉપરોક્ત (અ) અને (બ) પૈકી જ વધુ હોય, તે સિમેન્ટ કન્ટેન્ટ ને ફાઈનલ મીનીમમ સિમેન્ટ કન્ટેન્ટ પ્રતિ ઘનમીટર ગણવા હુકમ કરવામાં આવે છે.

ઉપરોક્ત બાબતની અમલવારી તાત્કાલિક અસરથી ચુસ્તપણે કરવાની રહેશે.

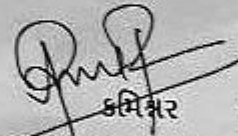
કમિશ્નર
રાજકોટ મહાનગરપાલિકા

નકલ રવાના (જાણ તથા અમલવારી અર્થે)

- નાયબ કમિશ્નરશ્રી (ઝોન-વેસ્ટ, સેન્ટ્રલ, ઇસ્ટ)

નકલ રવાના - (અમલવારી અર્થે)

- તમામ સીટી એન્જીનીયરશ્રી, એડી. સીટી એન્જીનીયરશ્રી, એક્ઝીક્યુટીવ એન્જીનીયરશ્રી, એન્વાયરમેન્ટ એન્જીનીયરશ્રી (S.W.M.)

R.M.C./C./ ૧૩૨

કમિશનર વિભાગ,
રાજકોટ મહાનગર સેવાસદન
તા. ૧૦/૬/૨૦૧૩

હુકમ :-

વિષય:- ઈ-ટેન્ડર / ઓપન ટેન્ડર પધ્ધતિથી મંગાવવામાં આવતી તમામ પ્રકારની ઓફરો સાથે બિનઅધિકૃત રજૂ થતાં ડોક્યુમેન્ટસ સામે કડક કાર્યવાહી હાથ ધરવા બાબત.

સંદર્ભ :- આ અગાઉનાં પરીપત્ર નં. આર.એમ.સી.સી./૩૨૯. તા.૨૨/૧૨/૨૦૧૨.

રાજકોટ મહાનગર સેવાસદનના ત્રણ જોનનાં તમામ વોર્ડમાં શહેરનાં વિકાસ તથા જાળવણી માટે વિવિધ કામગીરી કરાવવા ઈ-ટેન્ડર / ઓપન ટેન્ડર પધ્ધતિથી અલગ અલગ એજન્સીઓ પાસેથી સ્પર્ધાત્મક ધોરણે કામઘારી પ્રતિસ્પર્ધિયા ભાવો દુ બીડ સીસ્ટમ (૧) ટેકનીકલ બીડ (૨) પ્રાઈઝ બીડ થી મંગાવવામાં આવે છે.

સંદર્ભના પ્રસિધ્ધ કરેલ પરીપત્ર મુજબ તમામ ઈ-ટેન્ડર / ઓપન ટેન્ડરથી મંગાવવામાં આવતાં ભાવો સાથે ભાવ ભરનાર એજન્સીઓ / બીડરો દ્વારા ટેન્ડર બીડ માટે રજૂ કરવાનાં થતાં તમામ ડોક્યુમેન્ટસ ફરજિયાતપણે અરી નકલમાં અથવા સેલ્ફ એટેસ્ટેડ રજૂ કરવા આદેશ કરવામાં આવેલ છે. જે સંબંધે નીચે મુજબનાં હુકમની અમલવારી તાત્કાલીક અસરથી કરવા આદેશ કરવામાં આવે છે.

(૧) તમામ ટેન્ડરકાર્મોના ટેકનીકલ બીડ ઓપન કરતી વખતે જે ટેન્ડર બીડ ભરનાર એજન્સીઓ દ્વારા તમામ ડોક્યુમેન્ટસ કે તે પૈકી કોઈપણ એક ડોક્યુમેન્ટસ ખરી નકલમાં અથવા સેલ્ફ એટેસ્ટેડ રજૂ કરેલ ન હોય તો રજૂ થયેલ ટેકનીકલ બીડ ઓપન કરવાની કાર્યવાહી દરમ્યાન ટેકનીકલ બીડ ઓપન કરનાર સંબંધિત અધિકારીશ્રી / કર્મચારીશ્રીએ Disqualify પ્રકારનો રબર સ્ટેમ્પ બિનઅધિકૃત રજૂ થયેલ ટેન્ડરનાં તમામ પાને લગાવી ટેકનીકલ બીડમાં ટેન્ડર Disqualify ફરજિયાતપણે કરવાનું રહેશે.

જે ટેન્ડર ખરી નકલ કે સેલ્ફ એટેસ્ટેડ સાથે રજૂ થયેલ નથી, તેવું ટેકનીકલ બીડમાં ધ્યાને આવ્યેથી રજૂ થયેલ ટેન્ડરને Disqualify ન કરી, તે બીડરનું જો પ્રાઈઝ બીડ ખોલવામાં આવશે તો આવા પ્રાઈઝ બીડ ખોલનાર તમામ સંબંધિત અધિકારીશ્રી / કર્મચારીશ્રી સામે સખત શિસ્તાત્મક પગલાં લેવાની ફરજ પડશે.

(૨) તમામ ટેન્ડરોનાં ડિસ્ક્વાઈફમાં સંબંધિત ખરી નકલમાં રજૂ થયેલ તમામ ડોક્યુમેન્ટસની મુજબ (ઓરીજીનલ) નકલ મંગાવી તેની ખરી નકલની ચકાસણી ફરજિયાતપણે સંબંધિત ડી.ઈ.ઈ.શ્રી તથા મ.ઈ.શ્રી / અ.મ.ઈ.શ્રીએ કરવાની રહેશે. જે મુજબ નકલ સાથે વેરીફાઇ કર્યાની સહી ફરજિયાતપણે દરેક ખરી નકલમાં સંબંધિત ડી.ઈ.ઈ.શ્રી / મ.ઈ.શ્રી / અ.મ.ઈ.શ્રીએ કરવાની રહેશે. તે પહેલાં તે ટેન્ડરની પ્રાઈઝ બીડ ઓપન કરી શકાશે નહીં. જેમાં ફરજિયાત થયેથી સંબંધિત જવાબદાર ડી.ઈ.ઈ.શ્રી / મ.ઈ.શ્રી / અ.મ.ઈ.શ્રી ની સામે કડક ખાતાકીય પગલાં લેવાની ફરજ પડશે.

(૩) ક્રમ નં.(૧) તથા (૨) મુજબની ચકાસણી કરવા છતાં જે ડિસ્ક્વાઈફમાં ટેકનીકલ બીડ ઓપન કરતાં બીડર દ્વારા કોઈપણ પ્રકારનાં ફોલ ડોક્યુમેન્ટસ રજૂ કરી કામ મેળવવા માટે પ્રયાસ કર્યાનું સાબિત થશે, તેવા ડિસ્ક્વાઈફમાં બીડર / એજન્સીને બ્લોકલીસ્ટ કરી, આવા બીડર સામે ફરજિયાતપણે ફોજદારી કાર્યવાહી સંબંધિત શાખાના વડા તથા વીજલન્સ અધિકારીશ્રી (પ્રોટેક્શન) દ્વારા જોઈન્ટલી ટિન-૭ માં કરવા આદેશ કરવામાં આવે છે. જેની લેખિતમાં

જાણ તાત્કાલીક અર્થે કરવાની રહેશે, જેમાં શુક્ર વધેથી સંબંધીત તમામ અધિકારીશ્રી / કર્મચારીશ્રી સામે કડક પગલાં લેવા ફરજ પડશે.

- (૪) સંદર્ભનાં પરીપત્ર તથા આ હુકમ તમામ પ્રકારનાં ટેકનીકલ કામના ફરેક ટેન્ડર પ્રસિધ્ધ કરતી વખતે ટેન્ડરનો હિસ્સો ગણી ટેન્ડરના ભાગ તરીકે પ્રસિધ્ધ કરવાનું ફરજિયાત રહેશે, તથા બીડર દ્વારા ટેન્ડરમાં પ્રસિધ્ધ થતાં સંદર્ભનાં પરીપત્ર તથા આ હુકમનાં ફરેક પાને સહી સિક્કા સાથે ભરેલ ટેન્ડરની ટેકનીકલ બીડ કરજીયાત રજૂ કરવાની રહેશે.

ઉપરોક્ત હુકમનો તાત્કાલીક અસરથી ચુસ્તપણે અમલ કરવા આદેશ કરવામાં આવે છે.

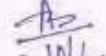
કમિશ્નર/૧૬

રાજકોટ મહાનગર સેવાસંઠન

નકલ રવાના (જાણ અર્થે):-
નાયબ કમિશ્નરશ્રીઓ (તમામ)

નકલ જાણ તથા અમલવારી અર્થે :-
(૧) સહાયક કમિશ્નરશ્રીઓ (તમામ)
(૨) શાખાધિકારીશ્રીઓ (તમામ)

આર.એમ.સી./સી. ૩૨૪

રાજકોટ મહાનગરપાલિકા
કમિશનર વિભાગ
તા.૨૨/૧૨/૨૦૧૨

પરિપત્ર:-

ઇ-ટેન્ડર પદ્ધતિ / ઓપન ટેન્ડર પદ્ધતિથી માંગવામાં આવતી ઓફરોમાં એજન્સીઓ દ્વારા ટેકનીકલ બીડમાં રજૂ કરવામાં આવતા ડોક્યુમેન્ટ્સ જેવા કે ટર્નઓવર, અનુભવના પ્રમાણપત્રો વિગેરે ખરી નકલમાં રજૂ કરવામાં આવતા નથી. આથી હવે પછીથી એજન્સીઓ દ્વારા રજૂ થતાં ટેકનીકલ બીડમાં રજૂ કરવામાં આવતા ડોક્યુમેન્ટ્સ ખરી નકલમાં અથવા સેલફ એટેસ્ટેડ હોવા જરૂરી છે તેમજ જે એજન્સીનું ટેન્ડર ટેકનીકલ બીડમાં ક્વોલીફાય થાય અને ખરી નકલ ગેઝેટેડ ઓફીસર મારફત પ્રમાણિત કરાવેલ ન હોય તેવા કેસમાં તેના ઓરીજીનલ ડોક્યુમેન્ટ્સ પ્રાઇસબીડ ખોલતા પહેલા ચકાસી અને ખરી નકલ રજૂ કરાવીને જ ખોલવાના રહેશે તથા આ બાબતનું શાખાધિકારીશ્રીઓએ ચુસ્તપણે પાલન કરાવવાનું રહેશે. આમ ન થયેથી પુરતી ચકાસણીને અભાવે જો કોઇ એજન્સીને ખોટા કે અધુરા આધારો સાથે કામ આપવાની ક્ષતિજનક બાબત જાણમાં આવ્યે તે ટેન્ડર ડોક્યુમેન્ટ્સની ચકાસણી કરનાર કર્મચારીશ્રીઓ તેમજ શાખાધિકારીશ્રીની જવાબદારી નક્કી કરવામાં આવશે, જેની સર્વે શાખાધિકારીશ્રીઓએ નોંધ લેવી.

ઉપરોક્ત બાબતનો અમલ તાત્કાલિક અસરથી કરવો.

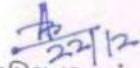
કમિશનર

રાજકોટ મહાનગરપાલિકા

નકલ રવાના :- (જાણ અર્થે)

- નાયબ કમિશનરશ્રીઓ (તમામ)

નકલ જાણ તથા અમલવારી અર્થે :-

- સહાયક કમિશનરશ્રીઓ (તમામ)

- શાખાધિકારીશ્રીઓ (તમામ)

જાહેરનામું

જોષ્ટાદારી કાર્યવીતી અધિનીયમ ૧૯૭૩ (૧૯૭૪ ના નં.૨) ની કલમ ૧૪૪ અન્વયે કાઢેલ ઢુકમ

ક્રમાંક એસ.બી./મજુર/જાહેરનામું/૧૬૩૬/૨૦૧૪.

પોલીસ કમિશ્નરશીની કચેરી.

રાજકોટ શહેર, રાજકોટ.

તા. ૨૬/૦૪/૨૦૧૪

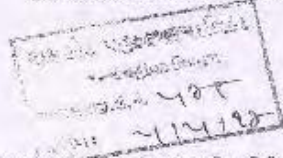

તાજિતરમાં રાજકોટ શહેરમાં ઘરકોટ ચોરીના બનાવો વધતા પડેલ છે. ભુતકાલના રાજકોટ શહેરમાં બનેલ ઘરકોટ ચોરીના બનાવોની તપાસ કરતા તપાસમાં આવા ગુનેા કરનાર (ઘરકોટીયા) પકડાયેલ છે. ત્યારે તપાસમાં આવા ગુનેા તાબા આરોપીઓ ગુનેાના બનાવના દિવસો અગાઉ રાજકોટ શહેરમાં નવા બંધાતા મકાનોમાં જુદી જુદી ઓધોગીક કાનીઓમાં, કોપોરેશનમાં મજુરી કામ અને ટેલીફોન કંપનીઓ સ્વારા તથા ગેસ પાઇપ લાઇન માટે ખોદાતા ખાડાઓની મજુરી કામ મેળાની ઘસવા તેના બહાના ફેકલ આવી રોકાણ કરી આગુવાજુની સ્થાનિક પરીશિતીનુ સર્વે કરી યાકીતસહ કલ મિલકત વિરુધ્ધના ગુનેાઓ આચરતા હોય છે. મજુરી કામના બહાના ફેકલ આતકવાદીઓ પણ આશરો મેળવી લેતા હોય છે તેથી જાહેર જનતાની જાન-માલ (મિલકત)ની સલામતી તથા સુરક્ષા માટે શ્રીકા નિર્વાચણી મુકવા જરુરી જણાય છે.

જિથી હુ મોકલ ગમ તા.૨૬.૪.૧૪, પોલીસ કમિશ્નર, રાજકોટ શહેર જોષ્ટાદારી કાર્યવીતી અધિનીયમ (સી.આર.પી.સી.) ૧૯૭૩ (૧૯૭૪ ના નં.૨) ની કલમ ૧૪૪ અન્વયે અધીને મુકાલ કરવાની કામે આની હુ ઢુકમ કલુ છુ કે, રાજકોટ શહેરના પોલીસ કમિશ્નર વિસ્તારમાં લેબર કોન્ટ્રાક્ટર/મુકાદમનાઓનો યોતની ખાસી જે મજુર કામે રાખેલ હોય અને મજુરી કામકાજ માટે સપ્લાય કરતુ હોય તેઓએ નીચે જણાવેલ કોમ મુકબ દરેક જાણીના કાલમ-અલગ કોમ ભરી ફરજુલાત પાઠે સ્થાનિક પોલીસ સ્ટેશનને કલ કરવાની રહેશે તથા મજુરી જવાને મજુરી કામ તથા રાજકોટ શહેર છોડી જતા રહે ત્યારે લેબર કોન્ટ્રાક્ટર/મુકાદમી તે અંગેની કલ્યા ભામ/સરનામા સહિતની વિગત સાથે સ્થાનિક પો રહે.મા કરવાની રહેશે

૧	લેબર કોન્ટ્રાક્ટર / મુકાદમ (સપ્લાયર) નુ પુરુ નામ સરનામુ	-
૨	ધો.નં., નંધાઃ સહિત	-
૩	મજુરનુ નામ તથા ઘે.વ.	-
૪	મજુરનુ કાલનુ સરનામુ ટેલીફોન નંબર	-
૫	મજુરનુ મુળ વતનનુ સરનામુ ગામ, તાલુકો, જિલ્લો	-
૬	કાલની મજુરીનુ સ્થાન / કંપનીનુ નામ	-
૭	મજુરનુ વતનનુ સ્થાનિક પો.સ્ટે.નુ નામ તથા ટેલીફોન નંબર	-
૮	મજુરના વતનના આગેવાનનુ નામ, સરનામુ, ટેલીફોન નંબર	-
૯	મજુર અગાઉ કોઇ પોલીસ ગુનેામાં પકડાયેલ હોય તો તેની વિગત	-
૧૦	કચારશી પુકાતો / કોન્ટ્રાક્ટરને મજુરી કામ માટે ભાળેલ છે	-
૧૧	મજુરનુ યોનામ માટેનુ અલ.કી.પુર (કોલ સાથે નુ)	-
૧૨	રાજકોટ શહેરમાં કલ તારીખથી મજુરી કામ કરે છે ? અને કલ તારીખે જવાની છે ?	-
૧૩	રાજકોટ શહેરમાં બજાડના સંલધી કોઇ કોવતો તેનુ નામ, સરનામુ	-

મજુરનો તાજિતરનો કોલ
 મજુરના અંગકાલુ નિશાલુ
 મુકાદમ/સપ્લાયર/કોન્ટ્રાક્ટરની સહી
 નામ.....

આ ઢુકમ તા. ૦૧/૦૫/૨૦૧૪ થી તા. ૩૦/૦૬/૨૦૧૪ મુધી અમલમાં રહેશે.

આ ઢુકમની લંગ કરનાર અસ્તિ ભુતનોચ દેઠ સહિતની કલમ ૧૮૦ મુકબ શિકાને પાત્ર થશે.

૧૬૨
 ૧૬૨
 ૨૧/૪/૨૦૧૪

તમામને વ્યક્તિગત રીતે જોડવાની બજવાણી કરવી શક્ય ન હોવા આથી એકતરફી રૂકમ કરી શકે તેવું જાહેર જનતાનો જાણ સારું સ્થાનિક વર્તમાન પણ આજ્ઞાવાણી અને ફરજીયાત કેન્દ્ર મારફતે પ્રસિધ્ધી દ્વારા તાજ પોલીસ સેવાઓ પોલીસ સબપેટર, મહાનગર પોલીસ કમિશર, નાગર પોલીસ કમિશર તથા પોલીસ કમિશર કચેરીના જોડાઈ શકે તેવા રૂકમની નકલ યોગ્ય પ્રસિધ્ધી કરવામાં આવશે તેમજ સંબંધિત સર્વે શકાય તેવી જાહેર જનતાઓ ઉપર રૂકમની નકલ યોગ્ય પ્રસિધ્ધી કરવામાં આવશે તુજરાત પોલીસ એકમ હયાત રહત મુજબ પોલીસ અધિકારીઓ પણ આ રૂકમની જાહેરાત કરવા અધિકૃત ગણાશે.

આજ તારીખે પોલીસ-સુબપેટર ના જોડાઈ શકી અને સિદ્ધી કરી આવેલ છે.



(મોકલેલ ત્રી)
 પોલીસ કમિશર
 રાજકોટ શહેર, રાજકોટ

જાહેર જનતા-

- (૧) અગ્ર સચિવશ્રી, મુક વિભાગ, ગાંધીનગર.
- (૨) પોલીસ મહાનિદેશક અને મુખ્ય પોલીસ અધિકારીશ્રી, ગુ. રા. ગાંધીનગર
- (૩) અધિક પોલીસ મુખ્ય નિદેશકશ્રી (ઈન્ડે.) ગુ. રા. ગાંધીનગર.
- (૪) પોલીસ કમિશરશ્રી, અમદાવાદ શહેર, ગોંડલ શહેર, સુરત શહેર.
- (૫) બાક મુખ્ય પોલીસ અધિકારીશ્રી, રાજકોટ શહેર, રાજકોટ.
- (૬) જીલ્લા પોલીસ અધિકારીશ્રી, રાજકોટ શહેર, રાજકોટ.
- (૭) સહકારશ્રી, રાજકોટ શહેર.
- (૮) મ્યુનિસિપલ કમિશરશ્રી, રાજકોટ શહેર.
- (૯) વિયામકશ્રી, માહિતી પ્રવૃત્તિ એકમવારુદ્ધ અનેક સરકાર મુખ્ય સચિવાલય ખેડી નં.૧, બીજા માથે, ગુ. રા., ગાંધીનગર.
- (૧૦) જીલ્લા સરકારી લેકલશ્રી, સેક્સ, શહેર, રાજકોટ.
- (૧૧) મેનેજરશ્રી, સર્વિસ પેરા, રાજકોટ, સર્વિસ સંસ્થાના માં પ્રસિધ્ધ કરવા માટે.
- (૧૨) પાલિકા પોલીસ કમિશરશ્રી, પુલ, પશ્ચિમ વિભાગ, રાજકોટ શહેર.
- (૧૩) આઈ.સી.કમિશરશ્રી (ઈન્ડે.), રાજકોટ સીક્રેટરિયટ, રાજકોટ.
- (૧૪) નાગર પોલીસ અધિકારીશ્રી, પો. ઈન્ડે.શ્રી, રાજકોટ શહેર, જાંજીરા પી.એ.
- (૧૫) તમામ પો.સે.ઈન્ચાર્જશ્રીઓ, રાજકોટ શહેર(નકલ) યોગ્ય લાઈસ સ્પીકર વ્યાજન દ્વારા જાહેરાત કરાવવા માટે)
- (૧૬) તમામ જાનોક તથા માથા ઈન્ચાર્જશ્રીઓ, રાજકોટ શહેર.
- (૧૭) ઠાણીયા ઈન્ચાર્જશ્રી, રાજકોટ શહેર (નકલ) વર્તમાનપત્રોને આપવી.
- (૧૮) ટેલર કમિશરશ્રી, ... તમામ ખાલતો સંબંધિતને જાવગત કરવા માટે

જાહેર સચિવાલય-

- (૧) રજીસ્ટ્રારશ્રી, રાજકોટ, ગુ. રા. સીક્રેટરિયટ અમદાવાદ.
 - (૨) રજીસ્ટ્રારશ્રી, ડિસ્ટ્રીક્ટ એન્ડ સેશન્સ કોર્ટ, રાજકોટ.
 - (૩) રજીસ્ટ્રારશ્રી, ગ્રીડ જ્યુડીકિયલ મેજી.શ્રી ડી.કે. રાજકોટ.
 - (૪) રજીસ્ટ્રારશ્રી, મેટ્રીકલ સેશન્સ કોર્ટ, રાજકોટ.
 - (૫) એકઝીક્યુટીવ મેજી.શ્રી, રાજકોટ શહેર
 - (૬) એકઝીક્યુટીવ મેજી.શ્રી, રાજકોટ તાલુકા
 - (૭) સર્વિસ માહિતી વિયામકશ્રી, રાજકોટ.
- (સ્થાનિક વર્તમાનપત્રો, આજ્ઞાવાણી તથા ફરજીયાત કેન્દ્રમાં પ્રસિધ્ધ કરવા અને વર્તમાનપત્રોની પ્રાપ્તિથી યોગ્યતા માટે)

૧૦૧



રાજકોટ મહાનગરપાલિકા

હિસાબી શાખા

ડો. આંબેડકર ભવન, ઢેબરભાઇ રોડ, રાજકોટ - ૩૬૦ ૦૦૧.

રા.મ.ન.પા./હિસાબીજા.નં. ૦૨૨

તા. ૧૬/૬/૨૦૧૭

નોંધ -

વિષય - Vendor Regi. માં GST No. Update કરવા બાબત

ઉપરોક્ત વિષયે જણાવવાનું કે રાજકોટ મહાનગરપાલિકા નાં તમામ વેન્ડર / કોન્ટ્રાક્ટરો નાં Vendor Registration માં GST No. ની જરૂરીયાત હોય તાત્કાલીક અપડેટ કરવા વિનંતિ. Temporary Vendor નાં Regi. આપની શાખામાં જ થઇ જશે જ્યારે Permanent Vendor નાં GST No. અપડેટ કરવા શાખા અધિકારીશ્રી નાં જરૂરી સહી સીકકા સાથે નીચે મુજબ વિગત નું પત્રક બનાવી દિવસ - ૭ માં હિસાબી શાખામાં માહિતી મોકલાવી આપવા વિનંતી.

Vendor Name	Exiting Vendor Regi. No.	PAN	GST NO.

1/1/16
જાણી (૨૨)
મો. નં. ૯૨૧૧૧૧૧૧
નોંધ - તમામ વિગતો ચકાસીને અપડેટ કરવી / ચકાસીને મોકલવી અન્યથા સપ્લાયર્સ ને TDS ની

ચીફ એકાઉન્ટન્ટ
રાજકોટ મહાનગરપાલિકા

કેડીટ મળશે નહીં જેની નોંધ લેવા વિનંતી.

નકલ અમલવારી અર્થે

1. તમામ શાખા અધિકારીશ્રી યો

નકલ સવિનય જાણ અર્થે

1. માન. કમિશ્નર સાહેબશ્રી
2. માન. નાયબ કમિશ્નર સાહેબશ્રી

રાજકોટ મહાનગરપાલિકા
સે. ઝોન બાંધકામ શાખા
ઈન્વર્ટ નંબર ૭૩૭
તારીખ ૧૬/૬/૧૭

આથી હું અમિત અરોરા (IAS), મ્યુનિસીપલ કમિશનર, રાજકોટ મહાનગરપાલિકા, રાજકોટ ગુજરાત પ્રોવિન્સીયલ મ્યુનિસીપલ કોર્પોરેશન એક્ટ-૧૯૪૯ની જોગવાઈ અનુસંધાને મળેલ સત્તા મુજબ, જાહેર હિતને ધ્યાને લઈ, રાજકોટ મહાનગરપાલિકા વિસ્તારમાં ઇમારત તોડવા, સમારકામ અથવા તો નવા બાંધકામ દરમ્યાન ઉપસ્થિત થતા બાંધકામએ લગત કચરા (Construction and Demolition Waste) નો રાજકોટ મહાનગરપાલિકા દ્વારા નિયત કરાયેલ જગ્યા સિવાય નિકાલ કરવા પ્રતિબંધ ફરમાવું છું.

એવું ધ્યાનમાં આવેલ છે જે, રાજકોટ મહાનગરપાલિકા વિસ્તારમાં ઇમારત, ઇમારતોના બાંધકામ દરમ્યાન નળીયા, પથરા, ઇંટો, ઇમારત બાંધવાના માલ સામાન અને એવા માલ સામાનનો કાટમાળ ગમે તે જગ્યાએ નિકાલ / એકઠો કરવામાં આવે છે. જેનાથી એવી જગ્યાએ ઉંદરો અથવા અન્ય જીવ જંતુઓનું આશ્રય સ્થાન અથવા ઉત્પત્તિ સ્થાન બને છે. તેમજ સદરહું જગ્યાનો ભોગવટો કરનારાઓને અથવા પડોશમાં રહેતી વ્યક્તિઓના ભય અને ઉપદ્રવનું કારણ બને છે. તેના કારણે રોગચાળો ફેલાવવાનો ભય અને લોકોના આરોગ્ય તથા જાનમાલને નુકસાન થાય તેવી સ્થિતિ ઉત્પન્ન થાય છે. તેમજ તે કચરો (Construction and Demolition Waste) દુર કરવા રાજકોટ મહાનગરપાલિકાને ખુબજ મોટો ખર્ચ થાય છે, તેમજ માનવ સમય બગડે છે. આમ, લોકોના જાનમાલના અને આરોગ્યના નુકસાનના ભોગે આવી ગેરકાયદેસર પ્રવૃત્તિ ચાલી રહેલ છે, આવી કોઇપણ પ્રવૃત્તિ જન આરોગ્ય માટે બિન સલામતી નોતરે તેમ હોય, ગુજરાત પ્રોવિન્સીયલ મ્યુનિસીપલ કોર્પોરેશન એક્ટ અનુસુચી-ક ના પ્રકરણ-૧૪ ની જોગવાઈઓ અનુસંધાને આવી તમામ પ્રવૃત્તિ કરવાનો અગાઉના જાહેરનામા નં.રા.મ.ન.પા./મ.ઓ./સો.વે.મે./જા.નં.૧૯૪૧, તા.૦૬/૦૮/૨૦૧૯ થી પ્રતિષેધ ફરમાવવામાં આવેલ અને આવા કચરા (Construction and Demolition Waste)ના નિકાલ માટે રાજકોટ મહાનગરપાલિકાએ નીચે દર્શાવેલ સ્થળો નિયત કરવામાં આવેલ.

૧. કોઠારીયા પોલીસ ચોકીની બાજુમાં પથ્થરની ખાણ પાસે,
૨. રૈયા સ્માર્ટ સીટીના તમામ ખાણ વિસ્તાર,
૩. ટી.પી.સ્કીમ નં.૧૦, એફ.પી.-૮૭, ઢેબર રોડ, સાઉથ અટીકા વિસ્તાર, પી.જી.વી.સી.એલ. ઓફિસ પાસે,
૪. ટી.પી.સ્કીમ નં.૨૩, એફ.પી.-૨૩, મોરબી રોડ, પોપટપરા આઇ.ઓ.સી. ગોડાઉન પાસે,
૫. સમ્રાટ ઇન્ડ. એરિયા, એસ.ટી. વર્કશોપ પાછળ, અનામત પ્લોટ,
૬. ટી.પી.સ્કીમ નં.૯, એફ.પી.-૫, રૈયાધાર ગાર્બેજ ટ્રાન્સફર સ્ટેશન પાસે,
૭. ટી.પી.સ્કીમ નં.૨૦, એફ.પી.-૩૫, પ્રધ્યુમન ગ્રીન પાછળ

ઉપરોક્ત સ્થળો ઉપરાંત નીચે મુજબના સ્થળો Construction and Demolition Waste ના નિકાલ માટે નિયત કરવામાં આવે છે.

૧. જેટકો ચોકડી, ટી.પી.સ્કીમ નં.૨૮, મવડી, એફ.પી.-૪૬/એ,
૨. ટી.પી.સ્કીમ નં.૧૨, કોઠારીયા નેશનલ હાઇવે, લીજજત પાપડ પાસે, એફ.પી.-૩૮/એ, ૩૯/બી.

ઉપરોક્ત નિયત કરેલ સ્થળો સિવાય અન્ય કોઇપણ જગ્યાએ કોઇપણ ઇસમ/ઇસમો છકડો, ટ્રેક્ટર અથવા ડમ્પર દ્વારા (Construction and Demolition Waste) નો નિકાલ કરતાં પકડાશે તો પ્રથમ વખત છકડો/ટ્રેક્ટર ઈઠ રૂ.૭,૫૦૦/- તથા ડમ્પર ઈઠ રૂ.૧૫,૦૦૦/-, બીજી વખત છકડો/ટ્રેક્ટર ઈઠ રૂ.૧૫,૦૦૦/- તથા ડમ્પર ઈઠ

રૂ.30,000/- અને ત્રીજી વખત છકડો/ટ્રેક્ટર દીઠ રૂ.40,000/- તથા ડમ્પર દીઠ રૂ.૧,૦૦,૦૦૦/-લેખે વહીવટી ચાર્જ વસુલ કરવામાં આવશે. તેમજ વાહન જપ્ત કરવા સુધીની કાર્યવાહી કરવામાં આવશે.

શહેરમાં વસતાં નાગરિકો દ્વારા ઉપરોક્ત Construction and Demolition Waste ના નિકાલ માટે રાજકોટ મહાનગરપાલિકા દ્વારા ઝોન વાઇઝ કામગીરી માટે Construction and Demolition Waste સેલની રચના કરવામાં આવેલ છે. શહેરના નાગરિકો રાજકોટ મહાનગરપાલિકાના કોલ સેન્ટર - ૦૨૮૧-૨૪૫૦૦૭૭ પર ફોન કરી તેમની મિલકતનાં રીપેરીંગ કે કાટમાળનો નિકાલ નીચે મુજબનાં નિયત થયેલ ચાર્જીસ ભરપાઇ કરી નિકાલ કરવાની વ્યવસ્થાનો લાભ મેળવી શકશે.

- રીક્ષા કે ૧/૨ ટ્રેક્ટર રૂ.૩૦૦/-
- ટ્રેક્ટર જેટલો જથ્થો રૂ.૫૦૦/-
- ટ્રક / ડમ્પર જેટલો જથ્થો રૂ.૧,૦૦૦/-

ઉપરોક્ત નિયત કરાયેલ સ્થળોએથી ખાનગી માલિકો, જુનો એકત્રિત થયેલ બાંધકામનો કાટમાળ પોતાના ઉપયોગ માટે સ્વખર્ચે ઉપાડી લઇ જઇ શકશે.

ઉક્ત જાહેરનામાનો ચુસ્તપણે અમલ કરવો.

રાજકોટ.

તા. 4/6/2022



કમિશનર
રાજકોટ મહાનગરપાલિકા

સંખ્યા: અ.સ. ૨૬૯ ૫૦૦૨/૪૨૯

સુધી બોલ સેમિનારી કચેરી,
૨૨મી અને નીચલી બવન,
૬૬૨૨ - ૧૩ - ૨૬૦૦ સ્ટ્રીટ,
ભાંધીયા,
વા. ૩ / ૭ / ૨૦૦૦

શ્રી
શ્રી ૧૦૩૦ સુપરગ્રામ સેવા,
આયુષ્ય ન.મં અને પદ્મ વિભાગ
મુમ્બઇ

વિષય: કરારખત પર સ્ટેમ ડ્યુટી વસુલાત બાબત

સંદર્ભ: આપની ક્વેરીનો તા. ૩૦/૭/૨૦૦૦નો પત્ર

અપરિચિત વિષય અને સંદર્ભ પત્ર દ્વારા આપની ક્વેરી દ્વારા "કરાર ખત" પર
સુપરગ્રામની સ્ટેમ ડ્યુટીના માર્ગદર્શન બાબતે જણાવવાનું કે, અંગ્રેજી ક્વેરીનો પરિપત્ર નં. સ્ટેમ
નં. ૧૪/૨૦૦૭/૯૩૯ તા. ૫/૨/૨૦૦૭ ના પરિપત્ર ની નકલ ખોલવામાં આવે છે. જેના પર
અને (૨)માં જણાવેલ સ્ટેમ ડ્યુટી વાપરવાની થાય છે.

વિશેષમાં જણાવવાનું કે, આપના દ્વારા અંગ્રે ૨૪ થયેલ વિગત અનુસાર અંગ્રેજી નં.
૧૪/૨૦૦૭ ના પરિપત્ર ના મુદ્દા નં.૨ મુજબ એડીમેન્ટ માટે રૂા. ૧૦૦/- તથા ડિપોઝીટ તરીકે બેંકમાં
વ્યાજ નોન-સાઈડેડ બેંકની રીફર ડિપોઝીટ તથા નાની બચત પત્રોની રૂા. ૫૦૦ (અઠી હજાર) રકમ રૂા.
૨૦,૦૦૦/- ઉપર આઈકલ - ૩૬ (૬) સાથે આઈકલ - ૨૦(૬)નો પ્રવચિત કર તથા
૨૦૦૦/- મુજબ સત્વાર્જસરિત ૧૦૦ જે ૪.૯% મુજબ સ્ટેમ ડ્યુટી ભરવામાં આવવામાં આવેલા
બંધો અંગ્રેજી નામ વામ છે. જે વિગત આપે.

૨૧-
૬૨૫
૨૨/૮/૦૦

Off. of the E. E. P.A.
R & B Div. Mumbai
31/8/2000
AUG 2000

સુપર
સ્ટેમ
અધિકારી બોલ સેમિનારી
મુમ્બઇ સેવા, ભાંધીયા
૧૨/૮/૨૦૦૦
૬૨૫

ન.સ્ટેમ્પ-આના-૧૪-૨૦૦૭-૯૩૯

સુપ્રિ.ઓફ સ્ટેમ્પસની કચેરી,
સ્ટેમ્પ અને નોંધણી ભવન,
સેક્ટર-૧૩-સી, ખ રોડ,
ગાંધીનગર.

તા. ૫-૨-૦૭

પરિપત્ર:-

અત્રેની કચેરીનાં ધ્યાન ઉપર આવેલ વિગત મુજબ ગુજરાત રાજ્યમાં આવેલ જીલ્લા પંચાયત, નગર પાલિકાઓ તરફથી કરવાના થતા બાંધકામ તથા અન્ય કામો માટે ટેન્ડર બહાર પાડી કોન્ટ્રાક્ટરો પાસે કામગીરી કરાવવામાં આવે છે. આવી કામગીરી માટે જે કોન્ટ્રાક્ટરનું ટેન્ડર મંજૂર કરવામાં આવે છે. તે ટેન્ડરની અંદાજીત રકમ પૈકી નિયમોનુસાર અનામતની (સીક્યુરીટી - ડીપોઝીટની) રકમ લેવામાં આવે છે. તે અંગે જીલ્લા પંચાયત / નગરપાલિકા / મહાનગરપાલિકા અને કોન્ટ્રાક્ટર વચ્ચે કરાર કરવામાં આવે છે. આવા કરારો સ્ટેમ્પ ડ્યુટીના અભિપ્રાય માટે અત્રે રજૂ કરવામાં આવે છે. તેમાં જે ડિપોઝીટની રકમ અનામત મુકવાની થાય છે. તે રોકડ, ચેક, ડીમાન્ડ ડ્રાફ્ટ બેંક ગેરંટી ક્રિકસ ડીપોઝીટ રીસીપ્ટ એન.એસ.સી. બચતપત્ર વિગેરે પૈકીના એક યા વધુ માધ્યમથી આપવામાં આવે છે. તેમાં ટેન્ડર અન્વયે કેટલી રકમ સીક્યુરીટી ડીપોઝીટ ગોટે મુકવાની છે અને કયા માધ્યમથી મુકવામાં આવે છે. તેની પુરેપુરી વિગત રજૂ કરેલ ન.હોય તો આવા કેસોમાં પુરેપુરી વિગત રજૂ કરવામાં ન આવે ત્યાં સુધી અભિપ્રાય આપી શકાતો નથી અથવા વિલંબ થાય છે. આવી પરિસ્થિતિ નિવારવા અને ટેન્ડરની રકમ અન્વયે જે કરાર કરવામાં આવે છે. તેમાં નીચેની વિગતો સ્ટેમ્પ ડ્યુટી લેવાની થાય છે.

(૧) અનામતની જે રકમ રોકડ, ચેક યા ડ્રાફ્ટથી લેવામાં આવે અથવા તો બેંક ગેરંટીથી આપવામાં આવે તો કરારના લેખ ઉપર મુબઈ સ્ટેમ્પ અધિનિયમ - ૧૯૫૮ની અનુસુચિ-૧ ના આર્ટીકલ - ૫ (ક) મુજબ કરાર ઉપર રૂ. ૧૦૦/- સ્ટેમ્પ ડ્યુટી વાપરવાની થાય છે.

(૨) ટેન્ડર અન્વયે જે અનામતની રકમ ક્રિકસ ડીપોઝીટ રીસીપ્ટ, એન.એસ.સી. યા અન્ય કોઈ બચતપત્રના માધ્યમ થી અનામત મુકવામાં આવે તો તેટલી અનામતની રકમ ઉપર મુબઈ સ્ટેમ્પ અધિનિયમ - ૧૯૫૮ની અનુસુચિ-૧ ના આર્ટીકલ - ૩૬ (ક) સાથે આર્ટીકલ ૨૦ (ક) મુજબ આ રીતે આપવામાં આવેલ અનામતની રકમના પ્રત્યેક રૂ. ૧૦૦/- અથવા તેના ભાગ માટે ૪.૨૫% પ્રમાણે સ્ટેમ્પ ડ્યુટીને યાજ બને છે.

આપના તરફથી જે કામો માટે ટેન્ડર બહાર પાડવામાં આવે અને તેમાં ટેન્ડરની રકમ અન્વયે જે રકમ ડિપોઝીટ (અનામત) મુકવામાં આવે છે. તેમાં ઉપર દર્શાવ્યા મુજબ સ્ટેમ્પ ડ્યુટીને યાજ બને છે. તે મુજબ અમલ કરવા ભવેનતી છે. સાથોસાથ આપના બ્યાર:

સુપ્રિ.ઓફ સ્ટેમ્પસની
કચેરી

કચેરી
નંબરપાલિકા કચેરી
ક્ર. નં. ૧૨૫૭
તા. ૦૨/૦૨/૦૭

- ૨૩ -

સુપ્રિ.ઓફ સ્ટેમ્પસની
કચેરી



કોન્ટ્રાક્ટરને વર્ક ઓર્ડર આપવામાં આવે તે સમયે કરારના આ ઉપર ઉક્ત વિગતે યોગ્ય સ્ટેમ્પ
ડયુટી ભરપાઈ કરેલ છે. કેમ? તેની પ્રકાશથી કરવા પણ જમાવવામાં આવે છે.



સચિવ શુભિ. જોડે સુરત
ગુજરાત રાજ્ય સરકાર

પ્રતિ, શ્રી જી બલ્લા કાંડેશ્વર
(સી) જીલ્લા વિકાસ અધિકારી,
જીલ્લા વિકાસ અધિકારીની કચેરી

(સી) મુનીશ્વર કમિશ્નરશ્રી,
મ્યુ. કમિશ્નરશ્રીની કચેરી

(સી) એક અધિકારી તમામ
નગરપાલિકા કચેરી,
(સી) પાલિકા : જી. સુરત

સાચી કલમ
સુરત જિલ્લા શિક્ષણ અધિકારી



RAJKOT MUNICIPAL CORPORATION
ACCOUNTS DEPARTMENT
Room No. 4, 2nd Floor
Dr. Ambedkar Bhavan,
Debar Road,
Rajkot - 360001

PARTY/VENDOR REGISTRATION FORM

VENDOR CODE	:	
Party Name	:	
Authorized Person	:	
PAN Card No.	:	
GST No.	:	
Address	:	
City	:	
Phone No.	:	
Mobile No.	:	
eMail ID	:	
Website	:	
Area Of Work	:	
Bank Details (attach copy of cancelled cheque)	:	
Bank Name	:	
Branch Name	:	
MICR Code	:	IFSC Code :
Account Type	:	
Account No.	:	

- (1) Any vendor while filling a tender shall quote registration details; if he is not registered he will give fresh details along with tender.
- (2) Accounts branch will designate a person who will keep the forms and also authorize new registrations or edit existing registrations.

TO,
CHIEF ACCOUNTANT,
ACCOUNT DEPARTMENT,
RAJKOT MUNICIPAL CORPORATION

THE ABOVE MENTIONED DETAILS FOR VENDOR REGISTRATION HAS BEEN VERIFIED BY US & FOUND CORRECT. KINDLY REGISTER ABOVE VENDOR.

SIGN
NAME
DESIGNATION
DEPARTMENT NAME

રાજકોટ મહાનગરપાલિકા

હિસાબી શાખા

તારીખ ૦૯/૨૦૧૮

જા. નં - ૧૬૧૭

પરિપત્ર :-

વિષય :- તા. ૦૧/૧૦/૨૦૧૮ થી જી.એસ.ટી. ટી.ડી.એસ. ની કપાત બાબત

સંદર્ભ :- (૧) GoI, MoF (Department of Revenue) Central Board Indirect Taxes and
Customs Notification No. 50/2018-Central Tax

(૨) GoG, Finance Department Notification No. 50/2018-State Tax

ઉપરોક્ત વિષય અને સંદર્ભે ગુજરાત ગુડ્સ એન્ડ સર્વિસ ટેક્સ એક્ટ, ૨૦૧૭ તથા સેન્ટ્રલ ગુડ્સ
એન્ડ સર્વિસ ટેક્સ એક્ટ, ૨૦૧૭ ની કલમ ૫૧ અનુસાર રૂ. ૨,૫૦,૦૦૦ થી વધુ રકમના વેરાપાત્ર
ચીજવસ્તુઓ ખરીદે કે વેરાપાત્ર સેવાઓ કોન્ટ્રાક્ટથી મેળવે તો કુલ ૨% (બે ટકા) ટેક્સ ડિડક્શન એટ સોર્સ
(જી.એસ.ટી. ટી.ડી.એસ) કપવાનો થાય છે.

આમ ઉપરોક્ત બાબતો ધ્યાને લઇ વધારાની રકમ ની વધારાની નિયમો અનુસાર બિલમાંથી તા.
૦૧/૧૦/૨૦૧૮ થી જી.એસ.ટી. ટી.ડી.એસ. ની કપાત કરવાની થાય છે.

નાયબ કમિશ્નર

રાજકોટ મહાનગરપાલિકા

બિડાણ :- GST FAQ's

નકલ સવિનય જાણ અર્થે:-

(૧) માન. કમિશ્નર સાહેબશ્રી

(૨) માન. નાયબ કમિશ્નર સાહેબશ્રી. (વે.ઓન. ઈ.ઓન.)

નકલ અમલવારી અર્થે:-

(૧) તમામ શાખા અધિકારીશ્રી

સા.મ.ન.પા.લી.ગલ.જા.ન. ૧૬૭૧
૨૧/૧૨/૧૬

સા.મ.ન.પા.લી.ગલ.જા.ન. ૧૬૭૧

રાજકોટ મહાનગરપાલિકા
લીંગલ શાખા
તા. ૨૧/૧૨/૨૦૧૬

પરિપત્ર :

વિષય : ઇ.પી.એફ. યોજના અંતર્ગત આપવાની થતી માહિતી

રાજકોટ મહાનગરપાલિકાની જુદી-જુદી શાખાઓમાં કરના વજાવતા કર્મચારી કે કર્મચારીને ઇ.પી.એફ. યોજના લાગુ પડે છે. અથવા તે જેઓને એક વખત આ યોજના લાગુ પડી ગયેલ હોય તેઓના ઇ.પી.એફ. એકાઉન્ટમાં કે.વાય.સી. (K.V.C) ફોર્મમાં આધાર કાર્ડ, પાનકાર્ડ તેમજ એકાઉન્ટની વિગતો જવા બોલાઇલ જાનર અપડેટ કરવાના બાકી હોય તેનું લીસ્ટ ઇ.પી.એફ. કચેરીમાં જે કર્મચારી/એકાઉન્ટ ડોલરની જરૂરી વિગતો પુરી પાડવામાં આવેલે ન હોય તે સત્વરે પુરી પાડવાની થાય છે. તથા અરેથી આ કાર્યકરોના સંકલન ગર્ભ નિયુક્ત કરવામાં આવેલ પેનલ એડવોકેટ તરફથી ઇ-મેઇલ મારફતે ચાલી પુરી પાડેલ છે. જે આ ગાથે સામેલ છે. સદરફું લીસ્ટના કર્મચારીઓની વિગત સંબંધિત શાખાએ દિન-૨ માં પેનલ એડવોકેટ અમલ કન્સલ્ટન્ટ ને અચુકપણે પહોંચતી કરવાની થાય છે.

આ ઉપરાંત રાજકોટ મહાનગરપાલિકાની જુદી-જુદી શાખાઓ વાસ સને ૨૦૧૨ થી આરટીઆર સ્ત્રી કોન્ટ્રાક્ટરો મારફતે કાર્ય કરાવેલ હોય જેમાં માતાવશસ્ત્રો ઉપલબ્ધ કર્યો હોય તે સંબંધિત કોન્ટ્રાક્ટરો ઇ.પી.એફ. એક્ટ તથા ઇ.એસ.આઇ. એક્ટ હેઠળ રજીસ્ટ્રેશન કરાવેલ છે કે કેમ તેની ખરેખર ખાતર જ સંબંધિત કોન્ટ્રાક્ટરશ્રીઓના બીલ પાસ કરવા અગાઉ સુચના આપવામાં આવેલ હતી. જેના કારણે ૨૦૧૬ સુધીના સુચના આપવામાં આવે છે. સંબંધિત કોન્ટ્રાક્ટરોની તથા તેઓ રક્તકના કમિટીની ઇ.પી.એફ. યોજના તરફથી આવેલ પત્રમાં દર્શાવેલ વિગતો તાત્કાલિક અસરથી પેનલ એડવોકેટશ્રીને દિન-૨ માં પહોંચતી કરવા ઉપર શાખાધિકારીને સુચિત કરવામાં આવે છે.

રાજકોટ મહાનગરપાલિકા
લિંગલ શાખા
કોર્ડ નં. ૩૩૨
તારીખ ૨૧/૧૨/૧૬

સદરજુ વિગત વિગત સમયમર્યાદામાં જ પરીચયાલ સંજોગોમાં બધલા તે ખાપુરો અને મોટી વિગતો મોકલવા બાબતે સંબંધિત શાખાઓની વ્યક્તિગત જવાબદારી નક્કી કરવામાં આવશે. જેમાં લીસ્ટમાં રજીસ્ટ્રા પુસ્તકોના સજકોટ મુલનગરપાલિકાના કમીસારીઓની વિગતો તથા શાખાની કચેરી કમલકામ મેન્ટ્રાકાર તથા તેઓ ઉસ્તકના જમિસીની વિગતો વોચર ચકાસણી કરી વિગત કરેલ સમયમર્યાદામાં પેનલ બેડવોકેટને પહોંચતી કરવી. તથા તેની જાણ લીગલ શાખાને કરવી

ઉપલેખા પરિપત્રની પુસ્તકો તાકાલિક બહારથી ચમલ કરવી

- જકલ સવિનય રવાના :-
- મહાન કમિશનર તાલુકા
 - નાયબ કમિશનર ટલ.જી. / સે.જી. ૩

 મુખ્ય કમિશનર
 સજકોટ મુલનગરપાલિકા

જકલ રવાના :-
 તમામ શાખાઓની (બમલસર)

પેનલ બેડવોકેટનું સરનામું :- શર્યા કનેલન્ટ
 ૫૦૨ મેન્ટ્રાકાર કચેરી
 ટાવોર રોડ, સાયકલ જીલ ઉપર
 સજકોટ, ડી.નં. ૨૪૩૩૩૮૦

નોંધ : સંબંધિત કોન્ટ્રાક્ટને ઇ.પી.બેડ. એસ. તથા ઇ.એસ.આ. બેડ. હેઠળ રજીસ્ટ્રેશન ન થયેલા હોય તેવા તમામ કોન્ટ્રાક્ટોના બીલી બોકીટ તથા કિમાબી શાખાને મંજૂર કરવા નહીં

સ.મ.ન.પા./લીગલ/જા.નં. ૧૮૧/૧૯

રાજકોટ મહાનગરપાલિકા

લીગલ શાખા

તા.૨૧/૨/૨૦૧૭

ક્રમ:

વસાણે : લીગલ ફાઇલ નં.૩૭૧/૨૦૧૬-૧૭

રાજકોટ મહાનગરપાલિકાની કામગીરી માટે જુદી-જુદી શાખાઓ દ્વારા કામગીરીના પ્રકારને ધ્યાને લઈ નિયમ અનુસારની પ્રક્રિયા અનુસારીને એજન્સી/સપ્લાયર/કોન્ટ્રાક્ટર સાથે જોગવાઈઓ કરાવવામાં આવે છે. મહાનગરપાલિકાની કામગીરી સંદર્ભે તૈયાર કરવામાં આવતા ટેન્ડર/કારનામામાં લખતી વખતની જરૂરીયાતને ધ્યાને લઈ આર્બિટ્રેશન (Arbitration) ની જોગવાઈઓનો સમાવેશ કરવામાં આવેલ છે.

રાજકોટ મહાનગરપાલિકાની કામગીરી માટે કરવામાં આવેલ કારનામાની શરતો અનુસંધાને અમુક એજન્સી/સપ્લાયર/કોન્ટ્રાક્ટર દ્વારા છેલ્લા કેટલાક વર્ષોથી નામદાર લાઇકોટ સમક્ષ આર્બિટ્રેટરશ્રીની નિયુક્તિ અંગે પીટીશનો કરવામાં આવે છે, જેના કારણે મહાનગરપાલિકાની કામગીરીના ભારણમાં વધારો થયેલ છે. અને સબંધિત અધિકારીશ્રીઓને વારંવાર અમદાવાદ ખાતે હાજર રહેવું પડતું હોય તેના કારણે અગત્યના પ્રોજેક્ટો સહીત કચેરીની કામગીરી તેમજ પ્રજાકીય કામો ઉપર વિપરીત અસર થવા પામેલ છે, તેમજ અરજદારોને હેરાન થવું પડે છે. આ અંગે કાયદાકીય, શાખાના અભિપ્રાય અને પ્રકરણની વિગતો જોતા આ કામે લેકલ્કેટિવ ઉપાય (alternative remedy) ઉપલબ્ધ હોય મહાનગરપાલિકાના ટેન્ડર/કારનામામાં આર્બિટ્રેશનની જોગવાઈઓને સામેલ કરવાનું ઉચિત જણાતું નથી.

આથી " રાજકોટ મહાનગરપાલિકાના કામે કરવામાં આવતા ટેન્ડર ડોક્યુમેન્ટ અને કારનામામાં આર્બિટ્રેશન (Arbitration) ને લગત જોગવાઈઓ દુર કરવાનો." અને તેના બદલે "ટેન્ડરની શરત/કારનામાની શરતના અર્થઘટન સંદર્ભે મહાનગરપાલિકાના કમિશનરશ્રીનો નિર્ણય આપરી અને બંધનકર્તા રહેશે." અને "ટેન્ડરની/કારનામાની શરતો અંગે કોઈ પણ બાબતે વિવાદ ઉપસ્થિત થયે રાજકોટની દિવાની અદાલતની હકુમત રહેશે." તેવી શરતોનો મહાનગરપાલિકાના કામ અર્થે તૈયાર કરવામાં આવતા તમામ કામગીરીના પરિપત્રો/ટેન્ડર ડોક્યુમેન્ટ તેમજ કારનામામાં સમાવેશ કરવાનો આથી હકુમ કરવામાં આવે છે.

આ હકુમનો અમલ તાત્કાલિક અસરથી ચુસ્તપણે કરવો.

કમિશનર

રાજકોટ મહાનગરપાલિકા

2

નકલ રવાના જાણ અર્થે : નાયબ કમિશનરશ્રી (તમામ)

નકલ રવાના જરૂરી કાર્યવાહી અર્થે : તમામ શાખાધિકારીશ્રીઓ



રાજકોટ મહાનગરપાલિકા
સોલિડ વેસ્ટ મેનેજમેન્ટ શાખા
WOW Cell

Azadi@75
સ્વચ્છ
સર્વેક્ષણ
#MeriShahar,MeriPecharan 2024

ડો. આંબેડકર ભવન, ઢેબરભાઇ રોડ, રાજકોટ

રા.મ.ન.પા./સો.વે.મે./જા.નં.-6445

તા.30-03-2024

હુકમ:

સંદર્ભ: રા.મ.ન.પા./સો.વે.મે./જા.નં ૮૬૬, તા. ૦૪-૦૬-૨૦૧૯

રાજકોટ મહાનગરપાલિકા વિસ્તારમાં વિકાસ કામો અને બાંધકામ પ્રવૃત્તિનો ખૂબ જ ઝડપથી વિકાસ થઈ રહેલ છે. જેના પરિણામે શહેરમાં કન્સ્ટ્રક્શન એન્ડ ડિમોલિશન વેસ્ટ પણ ખૂબ બહોળા પ્રમાણમાં ઉત્પન્ન થાય છે. આથી તેના કલેક્શન તથા યોગ્ય પદ્ધતિથી નિકાલની ખૂબ જ વિકટ સમસ્યા ઊભી થાય છે. કન્સ્ટ્રક્શન એન્ડ ડિમોલિશન (સી & ડી) વેસ્ટ રુલ્સ -2016 પ્રમાણે આ વેસ્ટનું કલેક્શન, સ્ટોરેજ તથા પ્રોસેસિંગ કરી યોગ્ય નિકાલ કરવો જરૂરી છે. જે અન્વયે આ અગાઉ ઉપરોક્ત સંદર્ભિત હુકમથી શહેરમાં ઉત્પન્ન થતા સી & ડી વેસ્ટના નિકાલ અન્વયેની માર્ગદર્શિકા નિયત કરવામાં આવેલ. જેની વધુ અસરકારકતા તથા કાર્યક્ષમતા સાથે પરિણામલક્ષી કામગીરી થઈ શકે તે માટે હવે પછીથી નીચે જણાવ્યા મુજબની વિગતે અમલવારી કરવા હુકમ કરવામાં આવે છે.

(૧) રાજકોટ મહાનગરપાલિકાની ટાઉન પ્લાનિંગ શાખા દ્વારા શહેરમાં આવેલ હયાત/જુના બાંધકામ ધરાવતી ઈમારતોને સ્થાને નવું બાંધકામ કરવા માટેની બાંધકામ પરવાનગી ઇસ્યુ કરતા પહેલા હાલની વ્યવસ્થા મુજબ જે ડિમોલિશન ચાર્જ લેવામાં આવે છે તેની સાથે શહેરમાં આવેલ આવી જૂની ઈમારતોનું બાંધકામ માલિક/કબજેદાર/ડેવલપર દ્વારા દૂર કરવાથી કેટલો સી & ડી વેસ્ટ ઉત્પન્ન (Generate) થશે તે બાંધકામ પરવાનગી અર્થે પ્લાન સહીતની વિગતો રજૂ કરનાર પરવાનેદાર એન્જિનિયરશ્રી/આર્કિટેકટશ્રી મારફત પ્રમાણિત કરાવી તેના જથ્થા મુજબ અને બાંધકામની પરવાનગીના પ્રકાર મુજબ આ ઉત્પન્ન થનાર સી & ડી વેસ્ટને નાકરાવાડી ખાતે આવેલ સી & ડી વેસ્ટ પ્રોસેસિંગ પ્લાન્ટ ખાતે નિકાલ કરવા માટેની ડિપોઝિટની રકમ પેટે રૂપિયા ૫૦૦૦/- (અંકે રૂપિયા પાંચ હજાર પુરા) વસુલવાની રહેશે. આ પ્રકારના તમામ કિસ્સાઓમાં ડીપોઝિટની રકમ જમા થયા બાદ જ ટાઉન પ્લાનિંગ શાખા દ્વારા શરતી બાંધકામ પરવાનગી (Conditional Permission) આપવાની રહેશે, તથા સદરહુ શરતી બાંધકામ પરવાનગીમાં સંલગ્ન જૂની ઈમારતના સી & ડી વેસ્ટને ટ્રાન્સપોર્ટ કરી સી & ડી વેસ્ટ પ્રોસેસિંગ પ્લાન્ટ ખાતે મોકલી આપવામાં આવ્યાનું પ્રમાણિત થયા બાદ જ ટાઉન પ્લાનિંગ શાખા દ્વારા બાંધકામ પરવાનગી આપવામાં આવશે અને ત્યારબાદ જ અરજદારશ્રી દ્વારા નવું બાંધકામ શરૂ કરવાનું રહેશે તેવો ઉલ્લેખ કરવાનો રહેશે.

શરતી બાંધકામ પરવાનગી મેળવ્યા બાદ અરજદારશ્રી દ્વારા તેઓના જુના મકાન/ઈમારતના ડીમોલિશનને કારણે નીકળેલ સી & ડી વેસ્ટને રાજકોટ મહાનગરપાલિકાના નાકરાવાડી ખાતે આવેલ સી & ડી વેસ્ટ પ્રોસેસિંગ પ્લાન્ટ પર મોકલવાની વ્યવસ્થા કરી નિકાલ કરવાનો રહેશે, તથા સી & ડી વેસ્ટ પ્રોસેસિંગ પ્લાન્ટ ખાતેથી આ અંગેની પહોંચ (રીસીપ્ટ)/પ્રમાણપત્ર મેળવી લેવાનું રહેશે.

સી & ડી વેસ્ટ પ્રોસેસિંગ પ્લાન્ટ ખાતે શહેરમાંથી સી & ડી વેસ્ટના નિકાલ અર્થે આવેલ મટીરીયલ અંગેનું રજીસ્ટર નિભાવવાનું રહેશે, તથા પ્લાન્ટ ખાતે સી & ડી વેસ્ટ લઈને આવેલ તમામ વાહન તથા તેના સી & ડી વેસ્ટના જથ્થાની નોંધ ઓનલાઈન નિયત એપ્લીકેશનમાં કરવાની રહેશે. પ્લાન્ટ ખાતે મેળવવામાં આવેલ સી & ડી વેસ્ટ મટીરીયલની પહોંચ (રીસીપ્ટ)/પ્રમાણપત્ર આપવા અંગેની જરૂરી તમામ વ્યવસ્થા સી & ડી વેસ્ટ પ્રોસેસિંગ પ્લાન્ટની એજન્સી દ્વારા કરવાની રહેશે.

ટાઉન પ્લાનિંગ શાખા દ્વારા ઉપરોક્ત જણાવ્યા મુજબ જુના બાંધકામ/ઈમારતના ડીમોલિશનને કારણે ઉત્પન્ન થયેલ સી & ડી વેસ્ટને અરજદારશ્રી દ્વારા નાકરાવાડી ખાતેના સી & ડી વેસ્ટ પ્રોસેસિંગ પ્લાન્ટ ખાતે

મોકલ્યાની ખરાઈ (Confirmation) કર્યા બાદ જ અરજદારશ્રી દ્વારા જમા કરવામાં આવેલ ડીપોઝીટની રકમ રૂ.૫૦૦૦/- (અંકે રૂપિયા પાંચ હજાર પુરા) પરત કરી બાંધકામ પરવાનગી ઇસ્યુ કરવાની રહેશે.

- (૨) ટાઉન પ્લાનિંગ શાખા દ્વારા કન્સ્ટ્રક્શન એન્ડ ડીમોલિશન વેસ્ટ રૂલ્સ ૨૦૧૬ ની માર્ગદર્શિકા મુજબ શહેરમાં જૂનો ઇમલો દૂર કરનાર એજન્સીઓ - કોન્ટ્રાક્ટરો દ્વારા સી & ડી વેસ્ટનું કલેક્શન તથા તેનું જરૂરી સેગ્રીગેશન કરી રાજકોટ મહાનગરપાલિકાના નાકરાવાડી ખાતે આવેલ સી & ડી વેસ્ટ પ્રોસેસિંગ પ્લાન્ટ ખાતે નિકાલ કરવાનું ફરજિયાત હોવાની બાબતની સમજ આપી તેઓનું રજીસ્ટ્રેશન કરાવી રાજકોટ મહાનગરપાલિકાની વેબસાઇટ પર શહેરમાં ઇમલો દૂર કરવાની કામગીરી કરતી આવી તમામ એજન્સીઓ - કોન્ટ્રાક્ટરોની યાદી મૂકવાની રહેશે.
- (૩) સોલિડ વેસ્ટ મેનેજમેન્ટ વિભાગ દ્વારા હાલ રાજકોટ મહાનગરપાલિકાના ત્રણેય ઝોનના જુદા જુદા વોર્ડ - વિસ્તારના પ્લોટ તથા રસ્તાઓની સાઈડમાં પડેલ સી & ડી વેસ્ટને કલેક્ટ કરી નાકરાવાડી ખાતે આવેલ સી & ડી વેસ્ટ પ્રોસેસિંગ પ્લાન્ટની જરૂરીયાત મુજબ પ્લાન્ટ ખાતે પહોંચાડવા (Transportation) ની વ્યવસ્થા કરવાની રહેશે, તથા શહેરના જાહેર રસ્તાઓ કે રાજકોટ મહાનગરપાલિકાના પ્લોટ પર અનઅધિકૃત રીતે સી & ડી વેસ્ટ ડમ્પિંગ ન થાય તે અંગેની તકેદારી રાખવા માટેની જરૂરી વ્યવસ્થા ઉભી કરવાની રહેશે.
- (૪) રાજકોટ મહાનગરપાલિકાની તમામ તાંત્રિક શાખા દ્વારા તેમના કાર્યક્ષેત્ર હેઠળ સિવિલ કામ કરતી તમામ એજન્સીઓ (ઝોનલ તથા ટેન્ડર કામ) ને સોંપવામાં આવેલ સિવિલ કામગીરી અંતર્ગત ઉત્પન્ન થનાર સી & ડી વેસ્ટના સંપૂર્ણ જથ્થાનો નિકાલ રાજકોટ મહાનગરપાલિકાની નાકરાવાડી ખાતે આવેલ સી & ડી વેસ્ટ પ્રોસેસિંગ પ્લાન્ટ ખાતે કરાવવાનો રહેશે.

આ માટે ઉત્પન્ન થયેલ સી & ડી વેસ્ટના જથ્થાને સંલગ્ન તાંત્રિક કામગીરી સંભાળતા એ.એ.ઈ.શ્રી તથા એ.ઈ.શ્રી દ્વારા તેમના નાયબ કાર્યપાલક ઇજનેરશ્રી મારફતે પ્રમાણિત કરાવી તે સી & ડી વેસ્ટના જથ્થાને સિવિલ કામની સંલગ્ન એજન્સી દ્વારા ટ્રાન્સપોર્ટેશનની વ્યવસ્થા કરી શહેરમાં અન્ય કોઈપણ જગ્યાએ નિકાલ ન કરી માત્ર નાકરાવાડી ખાતે આવેલ સી & ડી વેસ્ટ પ્રોસેસિંગ પ્લાન્ટ ખાતે જ જમા કરાવવાનો રહેશે, તથા પ્લાન્ટ ખાતેથી તે અંગેની પહોંચ (રીસીપ્ટ)/પ્રમાણપત્ર મેળવવાનું રહેશે. જે પહોંચ (રીસીપ્ટ)/પ્રમાણપત્ર સંલગ્ન તાંત્રિક શાખામાં રજૂ થયા બાદ તેને સંલગ્ન તાંત્રિક સ્ટાફ દ્વારા ચકાસણી કર્યા બાદ જ સંલગ્ન નાયબ કાર્યપાલક ઇજનેરશ્રી દ્વારા એજન્સીએ કરેલ કામની રકમનું ચૂકવણું કરવા માટેની બીલ અંગેની કાર્યવાહી હાથ ધરવાની રહેશે.

- (૫) રાજકોટ શહેરમાં ઉત્પન્ન થનાર સી & ડી વેસ્ટનો મહત્તમ રીચુઝ તથા રિસાયકલ થાય તે માટે કઈ કઈ બાંધકામ ઉપયોગી વસ્તુઓ (મટીરીયલ) બનાવી શકાય તથા તે તમામ મટીરીયલનો રાજકોટ મહાનગરપાલિકાના વિવિધ તાંત્રિક કામોમાં ઉપયોગ થાય તેવા મટીરીયલનો રાજકોટ મહાનગરપાલિકાના શેડ્યુલ ઓફ રેઈટસ (S.O.R.) માં સમાવેશ કરવા તથા રાજકોટ મહાનગરપાલિકાના વિવિધ સિવિલ કામમાં તેનો ઉપયોગ થાય તે સુનિશ્ચિત કરવા માટેની જરૂરી કાર્યવાહી હાથ ધરવાની રહેશે.

ઉપરોક્ત વિગતે સોંપવામાં આવેલ કામગીરીનો રિપોર્ટ નાયબ કમિશનરશ્રી (ઈસ્ટ ઝોન)ને કરવો. સદરહુ હુકમનો અમલ તાત્કાલિક અસરથી ચુસ્તપણે કરવાનો રહેશે.

કમિશનર

રાજકોટ મહાનગરપાલિકા

રા.મ.ન.પા./લીગલ/જા.નં. 1221

રાજકોટ મહાનગરપાલિકા
લીગલ શાખા,
રાજકોટ.
તા. 25/01/2023

પરિપત્ર:

વિષય: ઇ.પી.એફ. તથા ઇ.એસ.આઇ.સી. બાબતેનો અભિપ્રાય.
સંદર્ભ: ૧) રા.મ.ન.પા./હિસાબી/જા.નં. ૧૨૦૯ તા. ૧૦/૮/૨૦૨૩
૨) રા.મ.ન.પા. ઇન્વેડ નં. ૮૧૨ તા. ૨૧/૦૮/૨૦૨૩

ઉપરોક્ત વિષય તથા સંદર્ભે અન્વયે જણાવવાનું કે, સંદર્ભ - ૧ અન્વયેના પત્રથી હિસાબી શાખા દ્વારા ઇ.પી.એફ. તથા ઇ.એસ.આઇ.સી. લાગુ પાડવા બાબતેનો અભિપ્રાય માંગવામાં આવેલ હતો જે અનુસંધાને પેનલના એડવોકેટશ્રી તરફથી સંદર્ભ - ૨થી અભિપ્રાય આવેલ છે. સદરહું અભિપ્રાય રાજકોટ મહાનગરપાલિકાની તમામ શાખાને તથા શાખા હસ્તકના કોન્ટ્રાક્ટરોને લાગુ પડતો હોય જેથી સંબંધિત તમામ શાખાને સદરહું અભિપ્રાય વંચાણે લેવા સુચિત કરવામાં આવે છે.

આ ઉપરાંત આપની શાખાના કર્મચારી તથા કોન્ટ્રાક્ટરશ્રીઓની ઇ.એસ.આઇ.સી. અન્વયેની માહિતી આપવાની બાકી હોય તે તમામે દિન - ૦૨માં પેનલના એડવોકેટશ્રીને માહિતી પહોંચતી કરે અને તેની જાણ લીગલ શાખાને કરે અન્યથા તેમાંથી ઉત્પન્ન થતી તમામ જવાબદારી માટે વ્યક્તિગત રીતે જવાબદાર ઠેરવવામાં આવશે.

સદરહું પરિપત્રનો તાત્કાલિક અસરથી ચુસ્તપણે પાલન કરવું.

બિડાણ: સંદર્ભ-અન્વયેના પત્રો
નકલ સવિનય રવાના:

- નાયબ કમિશનરશ્રી (વે. ઝોન, ઇ. ઝોન)
- તમામ શાખાશિકારીશ્રીઓ (અમલ સાર)

રાજકોટ મહાનગરપાલિકા
એન્ડલેસિંગ વિભાગ

ઇન્વેડ નં. 2916.....

તારીખ 25/1/23

નાયબ કમિશનરશ્રી
રાજકોટ મહાનગરપાલિકા

મુદ્રા
જે.જી.પી.
૨૫/૧/૨૩

Shraddha Associates

LABOUR LAW CONSULTANT

Corrosp. Add. :

502, Accurate Square, Tagore Road,
Nr. Atul Motors, Above Cycle Zone, Rajkot.
Ph. O. 2463380, 93767 68952 E-Mail : dodiaparag@yahoo.in



Prop. : Parag J. Dodi
(Advocate & Labour Law Advisor)
Address : 2-Nalanda Bungalow
6-Pragati Society, Raiya Road, Rajkot.

Ref.

Date :

-06-2023.

પ્રતિ,
લેબર ઓફીસરશ્રી,
રાજકોટ મહાનગરપાલીકા,
રાજકોટ.

વિષય :- ઈપીએફ તથા ઈએસઆઈસી લાગુ પડવા રામનપા/હીસાબી/જા.નં.૧૨૦૮ પ્રાબલે અભિપ્રાય.
રેફ. :- રા.મ.ન.પા./લીગલ/જા.નં. ૧૦૮૦, તારીખ ૧૦/૦૮/૨૦૨૩.

મે. સાહેબશ્રી,

સવિનય સાથે જણાવવાનું કે, ઉપરોક્ત વિષય અને રેફરન્સથી આપના તરફથી અભિપ્રાય માંગવામાં આવેલ. જેની સાથે મોકલેલ ફોર્મટ મુજબ વિગતવાર રીમાર્ક્સ આપેલ છે.
રાજકોટ મહાનગરપાલીકાનાં શાખા અધિકારીએ બીલ બનાવતી વખતે બીલ બનાવતી વખતે નીચે મુજબનાં ડોક્યુમેન્ટ્સ ચેક કરી બીલ સાથે સામેલ કરવા જરૂરી છે.

દર મહીને લેવાનાં ડોક્યુમેન્ટ.

૧. પગારપત્રક (જેમાં દરેક કર્મચારી તથા કોન્ટ્રાક્ટરની સહી/સિકકો અને જે તે શાખા અધિકારીની સહી/સિકકો)
૨. હાજરી પત્રક.
૩. પી. એફ. ચલણ.
૪. પી. એફ. ઈ.સી. આર.
૫. ઈ.એસ.આઈ.સી. પેઈડ ચલણ.
૬. ઈ.એસ.આઈ.સી. લાગુ ન પડતો હોય તેવા કર્મચારી (રૂ.૨૧૦૦૦/- થી વધુ પગારવાળા) ની WC પોલીસી.
૭. પી.ટી. નાં ચલણ. (જે કર્મચારીનો પગાર રૂ.૧૨૦૦૦/- કે તેથી વધુ થતો હોય તેનાં.)
વાર્ષિક લેવાનાં ડોક્યુમેન્ટ.
૧. જો ૫૦ કે તેથી વધુ માણસો કોન્ટ્રાક્ટરમાં કામ કરતા હોય તો લેબર લાઈસન્સ.
૨. લેબર વાર્ષિક પત્રક.
૩. બોનસ પત્રક.
૪. જે તે ડીપાર્ટમેન્ટને લાગુ પડતા સરકારશ્રીનાં લાયસન્સની નકલ (ફુડ , ઈલેક્ટ્રીસીટી વગેરે)

દરેક શાખા હસ્તકનાં કોન્ટ્રાક્ટર / એજન્સી ઉપરોક્ત સંદર્ભ અન્વયે પાલન કરાવવાની જવાબદારી મુખ્ય માલિક તરીકે જે તે શાખાનાં શાખા અધિકારીની ઠરાવી શકાય.

સહકારની અપેક્ષા સહ.

આપનો વિશ્વાસુ,

SHRADDHA ASSOCIATES

PROPRIETOR

લીગલ ઈન્વર્ડ નં. 812
સરકારી ઈન્વર્ડ નં. -
25/08/23

બિડાણ :- ઉપર મુજબ.

EPF તથા ESI લાગુ પડે છે કે કેમ ?

ક્રમ	વારંવાર ઉદભવતા પ્રશ્નો.	લાગુ પડે છે કે કેમ ?	
		EPF	ESI
1	કોમ્પ્યુટર ખરીદી કરી અને રાજકોટ મહાનગરપાલીકાની જગ્યામાં ઈન્સ્ટોલેશન કરવાનું ધામ તો લાગુ પડે કે કેમ ?	ના	હા
2	રાજકોટ મહાનગરપાલીકાની જગ્યાનું સંચાલન કરતા કોન્ટ્રાક્ટર, વેન્ડર, ટ્રસ્ટ ને લાગુ પડે કે કેમ ? (જેમ કે સ્પોર્ટ સંકુલ, ગાર્ડન, પાર્કીંગ વગેરેનું સંચાલન કોન્ટ્રાક્ટર, ટ્રસ્ટ સંસ્થા વગેરે ધ્વારા કરવામાં આવે)	હા	હા
3	રસ્તા કામ, ટ્રેનેજ કામ, પાણી વિતરણની કામગીરી સાથે સંકળાયેલા કોન્ટ્રાક્ટરોને લાગુ પડે કે કેમ ?	હા	હા
4	જનરલ બોર્ડનાં માઈક સંચાલનનાં કોન્ટ્રાક્ટમાં લાગુ પડે કે કેમ ?	હા	હા
5	રાજકોટ મહાનગરપાલીકાનાં ગ્રાઉન્ડ સંચાલન કરતા કોન્ટ્રાક્ટરોને લાગુ પડે કે કેમ ?	હા	હા
6	આઉટ સોર્સીંગ સ્ટાફનાં કીસ્સામાં વેન્ડરને લાગુ પડે કે કેમ ?	હા	હા
7	રાજકોટ મહાનગરપાલીકાનાં રેનબસેરાનું સંચાલન કરતા કોન્ટ્રાક્ટરોને લાગુ પડે કે કેમ ?	હા	હા
8	રાજકોટ મહાનગરપાલીકાની જગ્યામાં ઈવેન્ટમેનેજમેન્ટ કરવામાં આવે ત્યારે ઈવેન્ટમેનેજમેન્ટ કંપનીને તથા ગાયક / આર્ટીસ્ટ / મ્યુઝીશીયનને લાગુ પડે છે કે કેમ ?	ના	ના
9	મશીન / વાહન ફક્ત પાર્ટસ ખરીદીનાં કિસ્સામાં લાગુ પડે છે કે કેમ ?	ના	ના
10	મશીન / વાહન ફક્ત પાર્ટસ ખરીદી અને ફીટીંગ / રીપેરીંગ રાજકોટ મહાનગરપાલીકાની જગ્યામાં કરવામાં આવતુ હોય તેવા કિસ્સામાં લાગુ પડે છે કે કેમ ?	હા	હા
11	મશીન / વાહન ફક્ત પાર્ટસ ખરીદી અને ફીટીંગ / રીપેરીંગ રાજકોટ મહાનગરપાલીકાની જગ્યામાં કરવામાં આવતુ હોય તેવા કિસ્સામાં લાગુ પડે છે કે કેમ ?	ના	ના
12	કોઈપણ ઈલેક્ટ્રીક વસ્તુની ખરીદી તથા તેનું ઈન્સ્ટોલેશન જેમ કે કેમેરા લાઈટ ફીટીંગ, કોમ્પ્યુટર, પ્રિન્ટર વગેરે કિસ્સામાં લાગુ પડે છે કે કેમ ?	ના	હા
13	મિત્ર મંડળ તથા સખી મંડળનાં કિસ્સામાં લાગુ પડે છે કે કેમ ?	હા	હા
14	ઓર્ગેનિઝેશન અને મેઈન્ટેનન્સ સર્વિસીઝ કોન્ટ્રાક્ટનાં કિસ્સામાં લાગુ પડે છે કે કેમ ?	હા	હા
15	ટુર્સ / ટાવેલ્સ ભાડે રાખવામાં આવેલ કાર્ડીવર સહીત તેવા કિસ્સામાં લાગુ પડે છે કે કેમ ?	હા	હા
16	ઈલેક્ટ્રીક પોલ ફીટ કરવા શિકટ કરવા અથવા નવા ઈન્સ્ટોલ કરવા વગેરે કિસ્સામાં લાગુ પડે છે કે કેમ ?	હા	હા



EPF તથા ESI લાગુ પડે છે કે કેમ ?			
17	એર કુલર, એ.સી. , વોટર કુલર રીપેરીંગ વગેરે કીસ્સામાં લાગુ પડે છે કે કેમ ?	હા	હા
18	રાજકોટ મહાનગરપાલીકાનાં કરાર આધારિત કર્મચારીનાં કીસ્સામાં લાગુ પડે છે કે કેમ ?	હા	હા
19	રજીસ્ટ્રેશન સમયે કુલ પગાર ઈ.પી.એફ. / ઈ.એસ.આઈ.સી. નાં નિયમ મુજબનાં પગારમર્યાદા કરતા ઓછી હોય પરંતુ ત્યારબાદ પગાર ઈપીએફ, ઈએસઆઈસી નાં નિયમ મુજબ પગાર મર્યાદા કરતા વધી તો ક્યાં સુધી કપાત કરવી. (ફીક્સમાંથી કાયમીનાં કીસ્સામાં / ફીક્સ પગાર વધી જાય તેવા કીસ્સામાં)	હા	ના
20	ફીક્સ / કાયમી થાય તેવા કીસ્સામાં લાગુ પડે છે કે કેમ ?	હા	હા
21	વાલ્વ ઓપરેટર તથા પમ્પ ઓપરેટરનાં કીસ્સામાં લાગુ પડે છે કે કેમ ?	હા	હા
22	લીગલ, પ્રોફેશનલ સર્વિસ રાજકોટ મહાનગરપાલીકાની જગ્યા પર આપવામાં આવે તેવા કીસ્સામાં લાગુ પડે છે કે કેમ ?	હા	હા
23	રાજકોટ મહાનગરપાલીકા ધ્વારા વિડીયોગ્રાફી / ફોટોગ્રાફી કરાવવામાં આવે તેવા કીસ્સામાં લાગુ પડે છે કે કેમ ?	હા	હા
24	રાજકોટ મહાનગરપાલીકાની જગ્યામાં ઝેરોક્ષ મશીન ચલાવે તેવા કીસ્સામાં લાગુ પડે છે કે કેમ ?	ના	ના
25	ન્યુઝ પેપર અથવા કોઈપણ વસ્તુ કે જેની ખરીદી કરી હોય અને જે રાજકોટ મહાનગરપાલીકાના પ્રીમાઈસીસ સુધી પહોંચાડવાની જવાબદારી વેન્ડરની હોય તેવા કીસ્સામાં લાગુ પડે છે કે કેમ ?	ના	ના
26	રાજકોટ શહેરમાં મોબાઈલ ડિસ્પેન્સરી ચલાવવા આપવામાં આવે તેવા કીસ્સામાં લાગુ પડે છે કે કેમ ?	હા	હા
27	ફક્ત એક વખત કામગીરી કરવાની હોય તેવા કીસ્સામાં લાગુ પડે છે કે કેમ ?	ના	ના
28	હોર્ડીંગ બોર્ડ ચડાવવા તથા ઉતારવાની કામગીરીનો એજન્સીને કોન્ટ્રાક્ટ આપેલ હોય તેવા કીસ્સામાં લાગુ પડે છે કે કેમ ?	હા	હા
29	રાજકોટ મહાનગરપાલીકાની જગ્યામાં કાર્ટીઝ રીપેરીંગ તથા રીફીલીંગ તેવા કીસ્સામાં લાગુ પડે છે કે કેમ ?	હા	હા
30	કેટરીંગ સર્વિસ અથવા હોટલમાંથી ફુડ પાર્સલ તેમજ કુરીયર સર્વિસ રાજકોટ મહાનગરપાલીકાને ડીલીવરી કરવામાં આવે તેવા કીસ્સામાં લાગુ પડે છે કે કેમ ?	ના	ના
31	સોલાર પેનલ તથા રૂફ ટોપ સોલાર પેનલનાં રાજકોટ મહાનગરપાલીકાની જગ્યામાં ઈન્સ્ટોલેશન તથા મેઈન્ટેનન્સનાં કીસ્સામાં લાગુ પડે છે કે કેમ ?	હા	હા

